

221 N COLLEGE AVE
FORT COLLINS, CO 80525



Building Size:

4,200 SF

Sale Price:

\$2,200,000

RARE OPPORTUNITY HISTORIC BUILDING ALONG COLLEGE AVENUE FOR SALE

- Mixed-use building with residential use on the second floor and retail/office on main floor
- 1,125 SF enclosed, secure parking space
- Historic features with modern renovations
- 100% leased - details available upon request



PROPERTY PHOTOS



Second Level - Residential Units

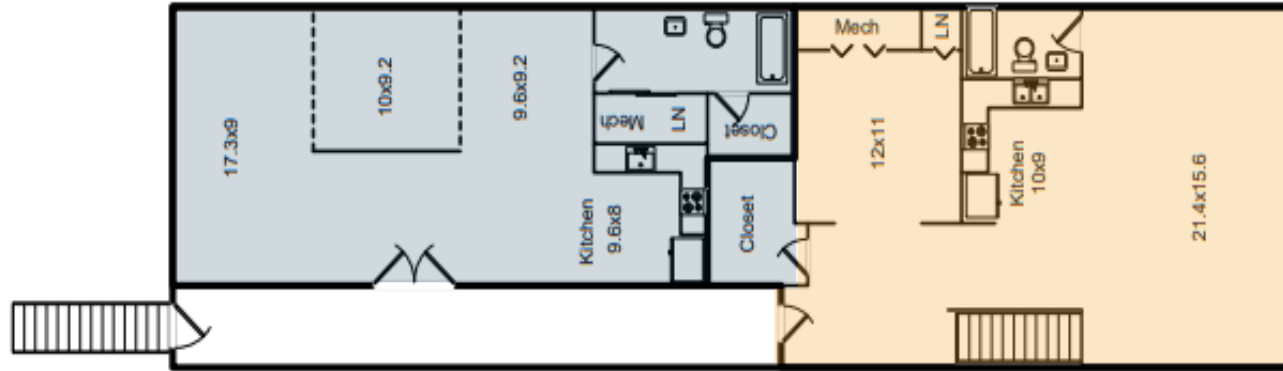

Main Level - Retail

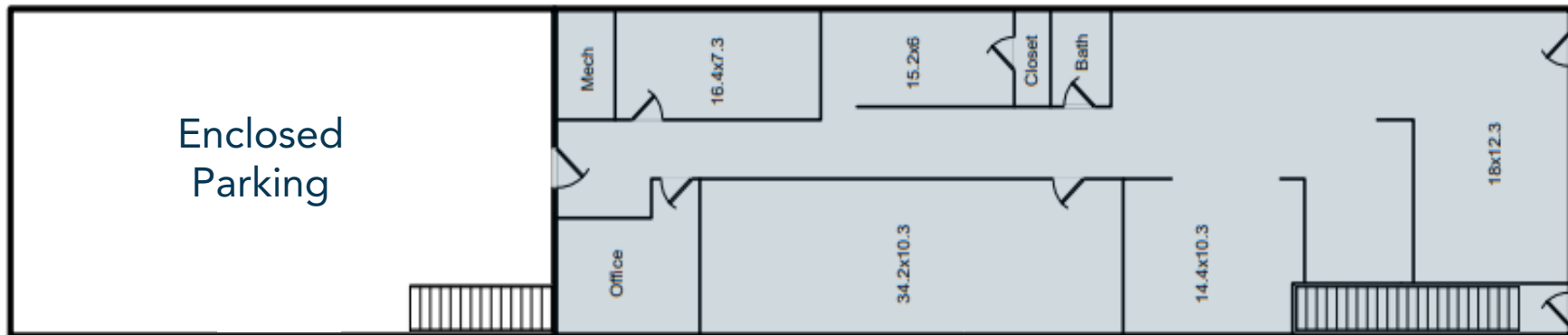

College Ave

PROPERTY FEATURES

Type:	Retail-Freestanding, Retail-Downtown, Live/Work
Acreage:	0.08 Acres
Lot Size:	3,485 SqFt
Zoning:	Downtown
Basement:	No Basement
Year Built:	1916
Construction:	Wood/Frame, Brick/Brick Veneer
Cooling:	Refrigeration/HVAC
Heating:	Forced Air
Roof:	Rubber/Membrane, Flat Roof
Lot Improvements:	Street Paved, Curbs, Gutters, Sidewalks, Street Light, Alley

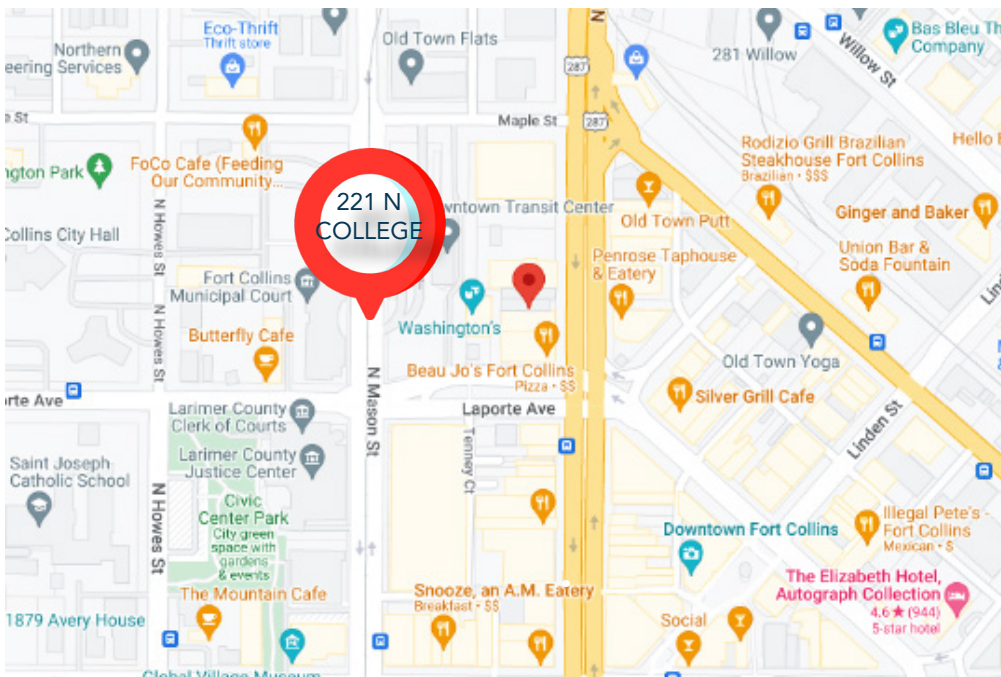

CONTACT: Josh Guernsey • 970-218-2331 • jguernsey@waypointRE.com
Greg Roeder • 970-213-2095 • groeder@livsir.com