

# Agilent 1100 Series Quaternary Pump



## Reference Manual



Agilent Technologies

# Notices

© Agilent Technologies, Inc. 2002

No part of this manual may be reproduced in any form or by any means (including electronic storage and retrieval or translation into a foreign language) without prior agreement and written consent from Agilent Technologies, Inc. as governed by United States and international copyright laws.

## Manual Part Number

G1311-90003

## Edition

Edition 07/02

Printed in Germany

Agilent Technologies  
Hewlett-Packard-Strasse 8  
76337 Waldbronn, Germany

## Software Revision

This guide is valid for A.01.xx revisions of the Agilent 1100 Series Quaternary Pump software, where xx refers to minor revisions of the software that do not affect the technical accuracy of this guide.

## Warranty

**The material contained in this document is provided “as is,” and is subject to being changed, without notice, in future editions. Further, to the maximum extent permitted by applicable law, Agilent disclaims all warranties, either express or implied, with regard to this manual and any information contained herein, including but not limited to the implied warranties of merchantability and fitness for a particular purpose. Agilent shall not be liable for errors or for incidental or consequential damages in connection with the furnishing, use, or performance of this document or of any information contained herein. Should Agilent and the user have a separate written agreement with warranty terms covering the material in this document that conflict with these terms, the warranty terms in the separate agreement shall control.**

## Technology Licenses

The hardware and/or software described in this document are furnished under a license and may be used or copied only in accordance with the terms of such license.

## Restricted Rights Legend

Software and technical data rights granted to federal government customers include only those rights customarily provided to end user Customers of Software. Agilent provides this customary commercial license in Software and technical data pursuant to FAR 12.211 (Technical Data) and FAR 12.212 (Computer Software) and, for Department of Defense purchases, DFARS 252.227-7015 (Technical Data - Commercial Items) and DFARS 227.7202-3 (Rights in Commercial Computer Software or Computer Software Documentation). If a federal government or other public sector Customer has a need for

rights not conveyed under these terms, it must negotiate with Agilent to establish acceptable terms in a written agreement executed by all relevant parties.

## Safety Notices

### CAUTION

A **CAUTION** notice denotes a hazard. It calls attention to an operating procedure, practice, or the like that, if not correctly performed or adhered to, could result in damage to the product or loss of important data. Do not proceed beyond a **CAUTION** notice until the indicated conditions are fully understood and met.

### WARNING

A **WARNING** notice denotes a hazard. It calls attention to an operating procedure, practice, or the like that, if not correctly performed or adhered to, could result in personal injury or death. Do not proceed beyond a **WARNING** notice until the indicated conditions are fully understood and met.

## In This Guide...

### **1 Installing the Pump**

How to install the quaternary pump

### **2 Optimizing Performance**

How to optimize the quaternary pump to achieve best chromatographic results

### **3 Troubleshooting and Test Functions**

The quaternary pump's built-in troubleshooting and test functions

This chapter describes the instrument's built in troubleshooting and test functions.

### **4 Repairing the Pump**

Instructions on simple, routine repair procedures as well as more extensive repairs requiring exchange of internal parts

### **5 Parts and Materials**

Detailed illustrations and lists for identification of parts and materials

### **6 Introduction to the Quaternary Pump**

An introduction to the pump, instrument overview, theory of operation, external communication and internal connectors

### **7 Control Module Screens for the Quaternary Pump**

This chapter is intended to introduce an operator to the screens available for operation of the Agilent 1100 quaternary pump with the Agilent 1100 control module.

Please use the manual of the control module for further detailed reference.

## **8 Specifications**

Performance specifications of the quaternary pump

# Contents

## 1 Installing the Pump

- Site Requirements 14
- Unpacking the Quaternary Pump 17
- Optimizing the Stack Configuration 20
- Installing the Quaternary Pump 23
- Flow Connections of the Quaternary Pump 26
- Priming and Purging the System 29

## 2 Optimizing Performance

- Hints for Successful Use of the Quaternary Pump 34
- Solvent Information 35
- Prevent Blocking of Solvent Filters 36
- Operational Hints for the Vacuum Degasser 38
- Operational Hints for the Multi Channel Gradient Valve (MCGV) 39
- When to use the Continuous Seal Wash Option 40
- When to Use Alternative Seals 41
- Optimize the Compressibility Compensation Setting 42

### 3 Troubleshooting and Test Functions

Overview of the Pump's Indicators and Test Functions	46
Status Indicators	47
Power Supply Indicator	47
Pump Status Indicator	48
Error Messages	49
Timeout	50
Shut-Down	51
Remote Timeout	52
Synchronization Lost	53
Leak	54
Leak Sensor Open	55
Leak Sensor Short	56
Compensation Sensor Open	57
Compensation Sensor Short	58
Fan Failed	59
Open Cover	60
Restart Without Cover	61
Zero Solvent Counter	62
Pressure Above Upper Limit	63
Pressure Below Lower Limit	64
Pressure Signal Missing	65
Missing Pressure Reading	66
Pump Configuration	67
Valve Fuse	68
Inlet-Valve Fuse	69
Valve Failed	70
Motor-Drive Power	71
Encoder Missing	72
Inlet-Valve Missing	73
Temperature Out of Range	74
Temperature Limit Exceeded	75

Servo Restart Failed	76
Pump Head Missing	77
Index Limit	78
Index Adjustment	79
Index Missing	80
Stroke Length	81
Initialization Failed	82
Wait Timeout	83
Pressure Test	84
Running the Pressure Test	85
Evaluating the Results	87
Potential Causes of Pressure Test Failure	88
Leak Test	89
Running the Leak Test	91
Evaluating the Results	93

#### 4 Repairing the Pump

Introduction into Repairing the Pump	98
Overview of the Repairing the Pump	100
Simple Repair Procedures	101
Exchanging the Active Inlet Valve	102
Exchanging the Active Inlet Valve Cartridge	104
Exchanging the Outlet Ball Valve	106
Exchanging the Purge Valve Frit or the Purge Valve	108
Removing the Pump Head Assembly	110
Exchanging the Pump Seals and Seal Wear-in Procedure	111
Seal Wear-in Procedure	113
Exchanging the Plungers	114
Installing the Continuous Seal Wash Option	116
Exchanging the Wash Seals	120
Reinstalling the Pump Head Assembly	123

Exchanging the Multi-Channel Gradient Valve (MCGV)	124
Exchanging the Optional Interface Board	126
Exchanging Internal Parts	127
Removing the Top Cover and Foam	128
Exchanging the Low Pressure Pump Main Board (LPM Board)	131
Exchanging the Damper	139
Exchanging the Fan	142
Exchanging the Pump Drive	144
Exchanging the Power Supply	148
Exchanging the Leak Sensor	153
Exchanging the Status Light Pipe	155
Assembling the Main Cover	156
Replacing the Top Cover and Foam	157

## 5 Parts and Materials

Overview of Main Assemblies	162
Control Module (B-version)	165
Solvent Cabinet	166
Bottle Head Assembly	167
Hydraulic Path	168
Cover Parts	169
Sheet Metal Kit	170
Foam Parts	171
Power and Status Light Pipes	172
Leak Parts	173
Pump Head Assembly	174
Pump Head Assembly with Seal Wash Option	176
Outlet Ball Valve Assembly	178



Purge Valve Assembly	179
Active Inlet Valve Assembly	180
Accessory Kit G1311-68705	181
Seal Wash Option Kit 01018-68722	182
Cable Overview	183
Analog Cables	185
Remote Cables	188
BCD Cables	194
Auxiliary Cable	197
CAN Cable	198
External Contact Cable	199
RS-232 Cable Kit	200
LAN Cables	201

## 6 Introduction to the Quaternary Pump

Introduction to the Quaternary Pump	204
Overview	205
How does the Pump Work?	206
How Does Compressibility Compensation Work?	208
How Does Variable Stroke Volume Work?	209
Electrical Connections	210
Instrument Layout	212
Early Maintenance Feedback (EMF)	213
EMF Counters	213
Using the EMF Counters	214
The Electronics	215
The Low-Pressure Pump Main Board (LPM)	216
Firmware Description	220
Firmware Updates	220

Optional Interface Boards	222
BCD Board	222
LAN Board	223
Agilent 1100 Series Interfaces	225
Analog Signal Output	226
GPIB Interface	226
CAN Interface	227
APG Remote Interface	227
RS-232C	228
Setting the 8-bit Configuration Switch	230
GPIB Default Addresses	231
Communication Settings for RS-232C Communication	232
Forced Cold-Start Settings	233
Stay Resident Settings	234
The Main Power Supply Assembly	235

## **7 Control Module Screens for the Quaternary Pump**

Major keys on the Agilent 1100 Control Module	238
Screens available from the Analysis screen	239
Screens available from the System screen	248
Screens available from the Records screen	250
Diagnostics and Tests	257

## **8 Specifications**

Performance Specifications	260
----------------------------	-----

## **A Safety Information**

General Safety Information	264
Lithium Batteries Information	267
Radio Interference	268
Sound Emission	269
Solvent Information	270
Agilent Technologies on Internet	271

## **Index**





# 1 Installing the Pump

Site Requirements	14
Unpacking the Quaternary Pump	17
Optimizing the Stack Configuration	20
Installing the Quaternary Pump	23
Flow Connections of the Quaternary Pump	26
Priming and Purging the System	29



### Site Requirements

A suitable environment is important to ensure optimum performance of the quaternary pump.

#### Power Consideration

The quaternary pump power supply has wideranging capability (see [Table 1](#) on page 15). It accepts any line voltage in the range described in the above mentioned table. Consequently there is no voltage selector in the rear of the quaternary pump. There are also no externally accessible fuses, because automatic electronic fuses are implemented in the power supply.

#### **WARNING**

**To disconnect the quaternary pump from line, unplug the power cord. The power supply still uses some power, even if the power switch on the front panel is turned off.**

---

#### **WARNING**

**Shock hazard or damage of your instrumentation can result, if the devices are connected to a line voltage higher than specified.**

---

#### Power Cords

Different power cords are offered as options with the quaternary pump. The female end of each of the power cords is identical. It plugs into the power-input socket at the rear of the quaternary pump. The male end of each of the power cords is different and designed to match the wall socket of a particular country or region.

#### **WARNING**

**Never operate your instrumentation from a power outlet that has no ground connection. Never use a power cord other than the power cord designed for your region.**

---

**WARNING**

Never use cables other than the ones supplied by Agilent Technologies to ensure proper functionality and compliance with safety or EMC regulations.

**Bench Space**

The quaternary pump dimensions and weight (see [Table 1](#) on page 15) allow to place the quaternary pump on almost any laboratory bench. It needs an additional 2.5 cm (1.0 inches) of space on either side and approximately 8 cm (3.1 inches) in the rear for the circulation of air and electric connections.

If the bench should carry a complete Agilent 1100 Series system, make sure that the bench is designed to carry the weight of all the modules.

**NOTE**

The pump should be operated in a horizontal position!

**Environment**

Your quaternary pump will work within specifications at ambient temperatures and relative humidity as described in [Table 1](#) on page 15.

**CAUTION**

Do not store, ship or use your quaternary pump under conditions where temperature fluctuations could cause condensation within the quaternary pump. Condensation will damage the system electronics. If your quaternary pump was shipped in cold weather, leave it in its box and allow it to warm slowly to room temperature to avoid condensation.

**Table 1** Physical Specifications

Type	Specification	Comments
Weight	11 kg (25 lbs)	
Dimensions (height × weight × depth)	140 × 345 × 435 mm (5.5 × 13.5 × 17 inches)	
Line voltage	100–120 or 220–240 VAC, ± 10%	Wide-ranging capability
Line frequency	50 or 60 Hz, ± 5%	

## 1 Installing the Pump

**Table 1** Physical Specifications (continued)

Power consumption	220 VA	Maximum
Ambient operating temperature	4–55 °C (41–131 °F)	
Ambient non-operating temperature	-40–70 °C (-4–158 °F)	
Humidity	< 95%, at 25–40 °C (77–104 °F)	Non-condensing
Operating Altitude	Up to 2000 m (6500 ft)	
Non-operating altitude	Up to 4600 m (14950 ft)	For storing the quaternary pump
Safety standards: IEC, CSA, UL	Installation Category II, Pollution Degree 2	



## Unpacking the Quaternary Pump

### Damaged Packaging

Upon receipt of your quaternary pump, inspect the shipping containers for any signs of damage. If the containers or cushioning material are damaged, save them until the contents have been checked for completeness and the quaternary pump has been mechanically and electrically checked. If the shipping container or cushioning material is damaged, notify the carrier and save the shipping material for the carrier's inspection.

### CAUTION

If there are signs of damage to the quaternary pump, please do not attempt to install the quaternary pump.

### Delivery Checklist

Ensure all parts and materials have been delivered with the quaternary pump. The delivery checklist is shown in [Table 2](#). To aid in parts identification, please see [Chapter 5](#), "Parts and Materials. Please report missing or damaged parts to your local Agilent Technologies sales and service office.

**Table 2** Quaternary Pump Checklist

Description	Quantity
Quaternary pump	1
Solvent cabinet	1 (5062-8581)
Solvent bottles	4 (3 transparent 9301-1420, 1 amber 9301-1450)
Bottle head assembly	4 (G1311-60003)
Waste tube, purge valve	1 (5062-2461, reorder number, 5m)
Vacuum degasser	1
Solvent tubes for the degasser	4 (G1322-67300)
Power cables	2

## 1 Installing the Pump

**Table 2** Quaternary Pump Checklist (continued)

Description	Quantity
CAN cable	1
Remote cable	As ordered
Signal cable	As ordered
<i>Reference Manual</i>	2 (1 for the pump, 1 for the degasser)
Accessory kit (see <a href="#">Table 3</a> )	1

### Accessory Kit Contents — Quaternary Pump

**Table 3** Accessory Kit Contents G1311-68705

Description	Part Number	Quantity
Capillary, pump to injection device	G1312-67305	1
Seal insert tool	01018-23702	1
Wrench; 1/4 – 5/16 inch	8710-0510	1
Wrench; 14 mm	8710-1924	1
ESD wrist strap*	9300-1408	1
Hex key 4mm	8710-2392	1
Waste tube (reorder number, 5m)	5062-2463	1.2 m
Velocity regulator (reorder number)	5062-2486	2
PTFE Frit	01018-22707	5

\* ESD: Electrostatic Discharge

**Accessory Kit Contents—Vacuum Degasser****Table 4** Accessory Kit Contents G1322-68705

<b>Description</b>	<b>Part Number</b>	<b>Quantity</b>
Syringe	5062-8534	1
Syringe adapter	9301-1337	1
Waste tube (reorder number, 5m)	5062-2463	1.2 m
Connecting tubes labeled A to D	G1322-67300	4

## Optimizing the Stack Configuration

If your quaternary pump is part of a complete 1100 Series system, you can ensure optimum performance by limiting the configuration of the system stack to the following configuration. This configuration optimizes the system flow path, ensuring minimum delay volume.

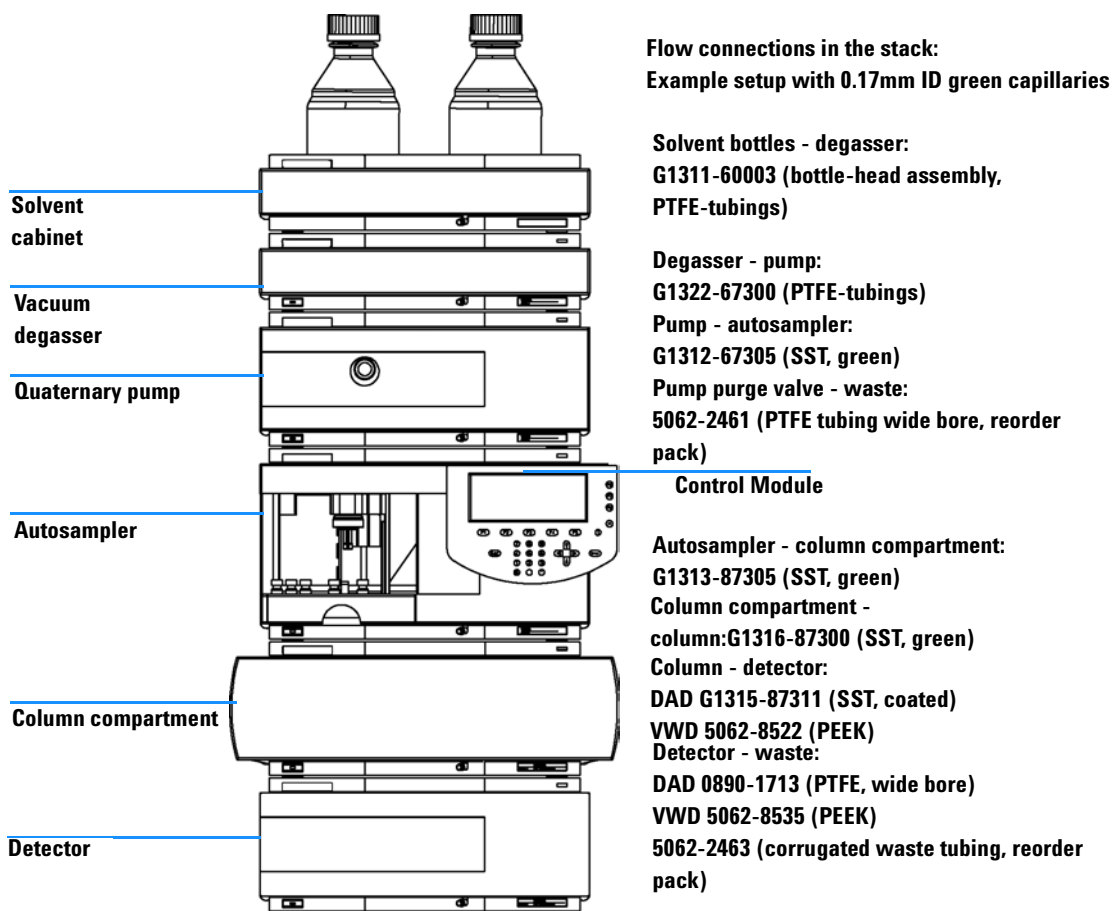

**Figure 1** Recommended Stack Configuration (Front View)

**NOTE**

For a detailed view of the flow connections refer to the section “Flow Connections” in chapter 1 of the reference manuals of the individual modules.

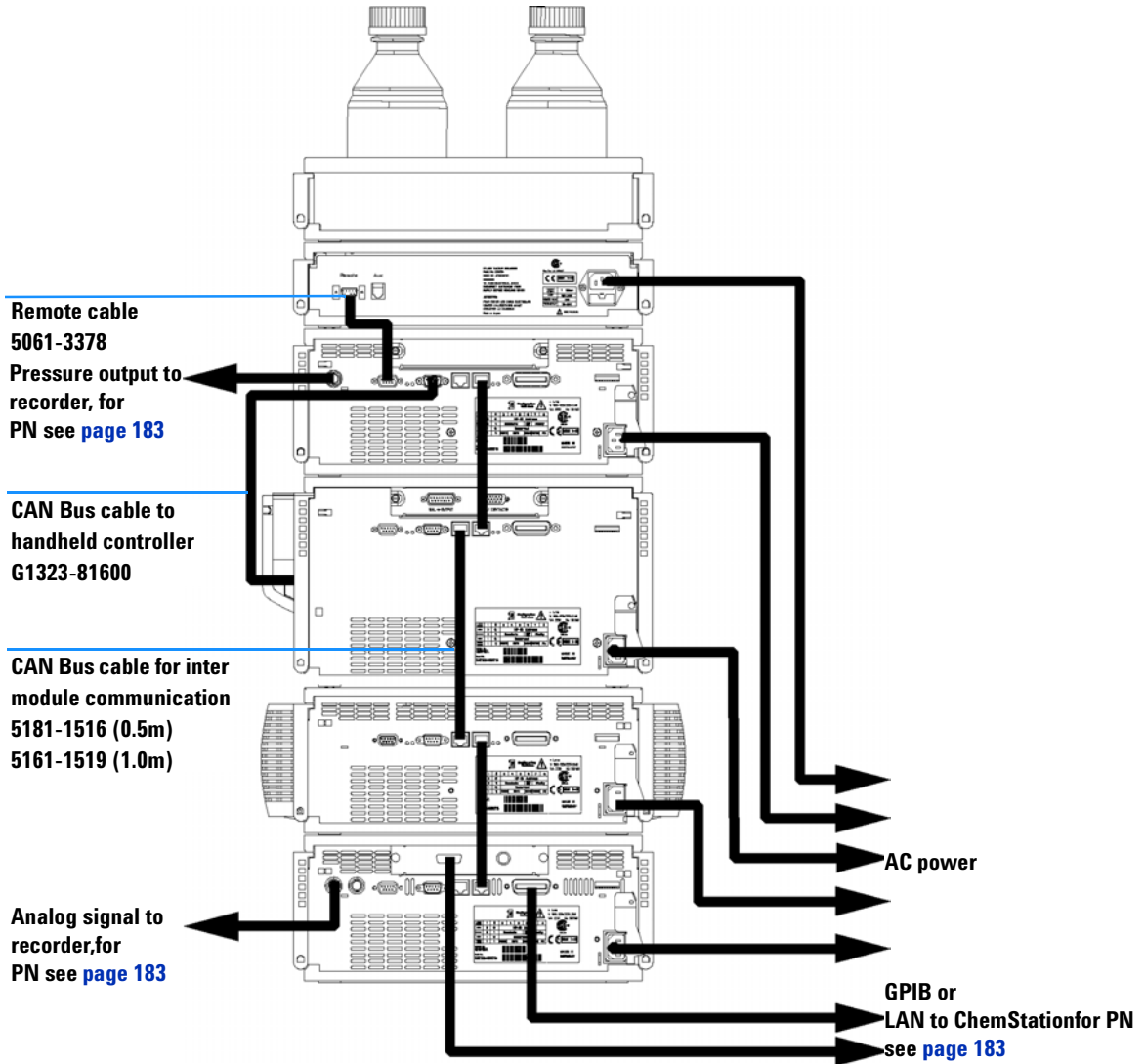

**Figure 2** Recommended Stack Configuration (Rear View)

## 1 Installing the Pump

### NOTE

If a single stack configuration becomes too high, e.g. if an additional module like a G1327A ALS Thermostat is added or if your bench is too high, a two stack configuration may be a better setup. Separate the stack between pump and autosampler and place the stack containing the pump on the right side of the stack containing the autosampler.

---

## Installing the Quaternary Pump

<b>Preparations</b>	Locate bench space. Provide power connections. Unpack the pump.
<b>Parts required</b>	Pump Power cord, for other cables see text below and <a href="#">"Cable Overview"</a> on page 183 ChemStation and/or Control Module G1323A/B

- 1 Place the quaternary pump on the bench in a horizontal position.
- 2 Ensure the power switch on the front of the quaternary pump is OFF (switch stands out).

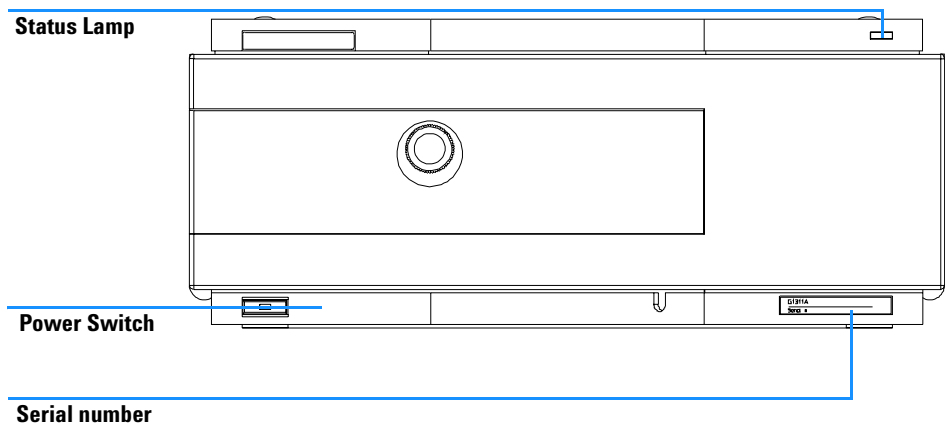

**Figure 3** Front of Quaternary Pump

- 3 At the rear of the quaternary pump move the security lever to its maximum right position.
- 4 Connect the power cable to the power connector at the rear of the quaternary pump. The security lever will prevent that the cover is opened while the power cord is connected to the quaternary pump.
- 5 Connect the required interface cables to the quaternary pump.





**NOTE**

The power switch stays pressed in and a green indicator lamp in the power switch is on when the quaternary pump is turned on. When the line power switch stands out and the green light is off, the quaternary pump is turned off.

---

- 8 Purge the quaternary pump (see "[Priming and Purging the System](#)" on page 29).

**WARNING**

**To disconnect the quaternary pump from line, unplug the power cord. The power supply still uses some power, even if the power switch on the front panel is turned off.**

---

**NOTE**

The pump was shipped with default configuration settings. To change these settings, "[Setting the 8-bit Configuration Switch](#)" on page 230

---

## Flow Connections of the Quaternary Pump

**Preparations**  
**Parts required**

Pump is installed in the LC system.  
Other modules

Parts from accessory kit, see "[Accessory Kit Contents — Quaternary Pump](#)"  
on page 18

Two wrenches 1/4–5/16 inch for capillary connections

**WARNING**

When opening capillary or tube fittings solvents may leak out. Please observe appropriate safety procedures (for example, goggles, safety gloves and protective clothing) as described in the material handling and safety data sheet supplied by the solvent vendor, especially when toxic or hazardous solvents are used.

- 1 Remove the front cover by pressing the snap fasteners on both sides.

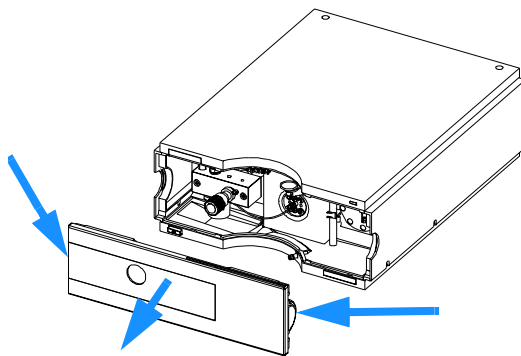
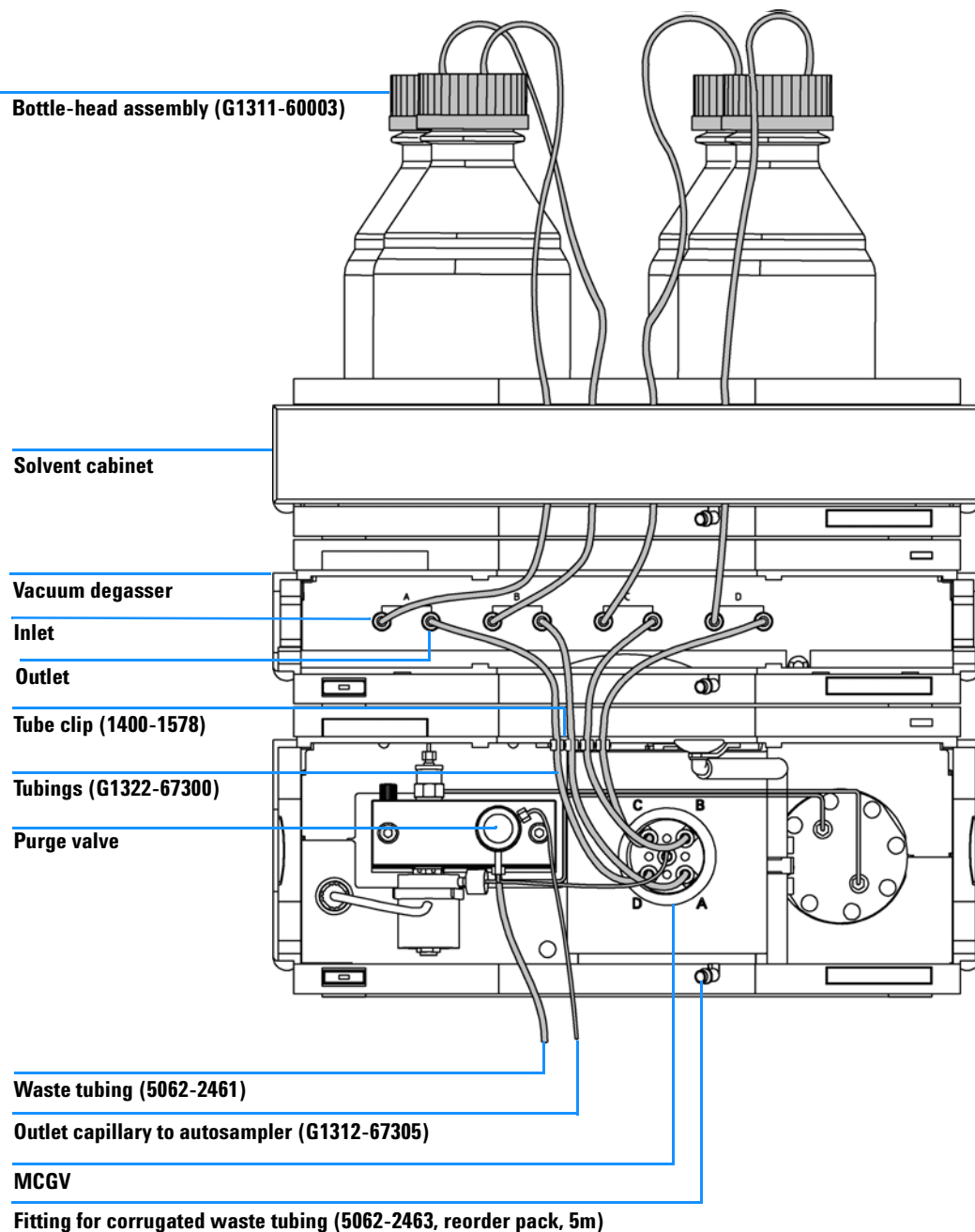

**Figure 5** Removing the Front Cover

- 2 Place the vacuum degasser and the solvent cabinet on top of the quaternary pump.
- 3 Put the bottle-head assemblies into solvent reservoirs containing your mobile phase and place the bottle in the solvent cabinet.

- 4 Connect the inlet tubes from the bottle-head assemblies to the inlet connectors A to D (typically the left connection of the channel) of the vacuum degasser. Fix the tubes in the tube clips of the vacuum degasser.
- 5 Connect the solvent tubes to the outlet connectors (typically right connection of the channel) of the vacuum degasser.
- 6 Connect the syringe adapter from the degasser accessory kit to the solvent tube of channel A.
- 7 Using a piece of sanding paper connect the waste tubing to the purge valve and place it into your waste system.
- 8 If the quaternary pump is not part of a Agilent1100 System stack or placed on the bottom of a stack, connect the corrugated waste tube to the waste outlet of the pump leak handling system.
- 9 Connect the pump outlet capillary (quaternary pump to injection device) to the outlet of the purge valve.
- 10 Prime your system before first use (see "[Priming and Purging the System](#)" on page 29).

## 1 Installing the Pump



**Figure 6** Flow Connections of the Quaternary Pump

## Priming and Purging the System

The system can be primed either by drawing solvent through the degasser with a syringe or by pumping with the pump.

Priming the system with a syringe is recommended, when:

- vacuum degasser or connected tubings are used for the first time or vacuum tubes are empty or
- changing to solvents that are immiscible with the solvent currently in the vacuum tubes.

Priming the system by using the pump at high flow rate (3–5 ml/min) is recommended, when:

- pumping system was turned off for a length of time (for example, overnight) and if volatile solvent mixtures are used, or
- solvents have been changed.

### WARNING

**When opening capillary or tube fittings solvents may leak out. Please observe appropriate safety procedures (for example, goggles, safety gloves and protective clothing) as described in the material handling and safety data sheet supplied by the solvent vendor, especially when toxic or hazardous solvents are used.**

---

### Priming with a Syringe

Before using a new degasser or new tubings for the first time:

- 1 Prime all tubings with at least 30 ml of iso-propanol no matter whether the channels will be used with organic mobile phase or with water.

If you are changing to a solvent that is immiscible with the solvent currently in the tubing continue as follows:

- 2 Replace the current solvent with adequate organic solvent (see [Table 5](#) on page 31), if current solvent is organic or with water, if current solvent is an inorganic buffer or contains salt.
- 3 Disconnect solvent outlet tube of the channel that is supposed to be primed from your pump.
- 4 Connect syringe adapter to solvent outlet tube.
- 5 Push syringe adapter onto syringe.

## 1 Installing the Pump

- 6 Pull syringe plunger to draw at least 30 ml of solvent through degasser and tubing.
- 7 Replace the priming solvent with the new solvent of your choice.
- 8 Pull syringe plunger to draw at least 30 ml of solvent through degasser and tubing.
- 9 Disconnect syringe adapter from solvent tube.
- 10 Connect the solvent tube to the appropriate channel of the MCGV.
- 11 Repeat [step 3](#) to [step 10](#) for the other solvent channels.

### NOTE

When priming the vacuum degasser with a syringe the solvent is drawn through the degasser tubes very quickly. The solvent at the degasser outlet will therefore not be fully degassed. Pump for approximately 10 minutes with your selected flow rate before starting any application. This will allow the vacuum degasser to properly degas the solvent in the degasser tubes.

### NOTE

The pump should never be used for priming empty tubings (never let the pump run dry). Use the syringe to draw enough solvent for completely filling the tubings to the pump inlet before continuing to prime with the pump.

### Priming with the Pump

When the pumping system has been turned off for a certain time (for example, overnight) oxygen will rediffuse into the solvent channels between the vacuum degasser and the pump. Solvents containing volatile ingredients will slightly lose these, if left in the degasser without flow for a prolonged period of time. Therefore priming of the vacuum degasser and the pumping system is required before starting an application.

- 1 Open the purge valve of your pump (by turning it counterclockwise) and set flow rate to 3-5 ml/min.
- 2 Flush the vacuum degasser and all tubes with at least 30 ml of solvent.
- 3 Set flow to required value of your application and close the purge valve.
- 4 Pump for approximately 10 minutes before starting your application.
- 5 Repeat [step 1](#) to [step 4](#) for other solvent channels, where needed.

**Table 5** Choice of Priming Solvents for Different Purposes

<b>Activity</b>	<b>Solvent</b>	<b>Comments</b>
After an installation	Isopropanol	Best solvent to flush air out of the system
When switching between reverse phase and normal phase (both times)	Isopropanol	Best solvent to flush air out of the system
After an installation	Ethanol or Methanol	Alternative to Isopropanol (second choice) if no Isopropanol is available
To clean the system when using buffers	Bidistilled water	Best solvent to re-dissolve buffer crystals
After a solvent change	Bidistilled water	Best solvent to re-dissolve buffer crystals
After the installation of normal phase seals (P/N 0905-1420)	Hexane + 5% Isopropanol	Good wetting properties

## **1 Installing the Pump**



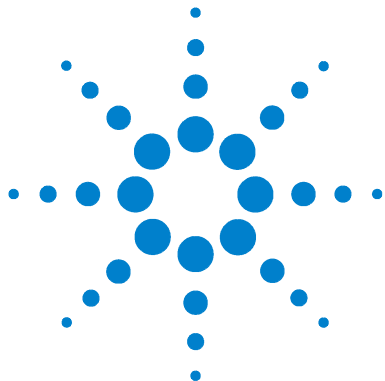

## 2 Optimizing Performance

Hints for Successful Use of the Quaternary Pump	34
Solvent Information	35
Prevent Blocking of Solvent Filters	36
Operational Hints for the Vacuum Degasser	38
Operational Hints for the Multi Channel Gradient Valve (MCGV)	39
When to use the Continuous Seal Wash Option	40
When to Use Alternative Seals	41
Optimize the Compressibility Compensation Setting	42



### Hints for Successful Use of the Quaternary Pump

- Always place the solvent cabinet with the solvent bottles on top of the quaternary pump (or at a higher level).
- When using salt solutions and organic solvents in the Agilent 1100 Quaternary Pump it is recommended to connect the salt solution to one of the bottom gradient valve ports and the organic solvent to one of the upper gradient valve ports. It is best to have the organic channel directly above the salt solution channel. Regular flushing with water of all MCGV channels is recommended to remove all possible salt deposits in the valve ports.
- Before operating the quaternary pump flush the vacuum degasser with at least two volumes (30 ml), especially when turned off for a certain length of time (for example, during the night) and volatile solvent mixtures are used in the channels (see ["Priming and Purging the System"](#) on page 29).
- Prevent blocking of solvent inlet filters (never use the pump without solvent inlet filter). Growth of algae should be avoided (see ["Prevent Blocking of Solvent Filters"](#) on page 36).
- Check purge valve frit and column frit in regular time intervals. A blocked purge valve frit can be identified by black or yellow layers on its surface or by a pressure greater than 10 bar, when pumping distilled water at a rate of 5 ml/min with an open purge valve.
- When using the quaternary pump at low flow rates (for example, 0.2 ml/min) check all 1/16-inch fittings for any signs of leaks.
- Whenever exchanging the pump seals the purge valve frit should be exchanged, too.
- When using buffer solutions, flush the system with water before switching it off. The seal wash option should be used when buffer concentrations of 0.1 Molar or higher will be used for long time periods.
- Check the pump plungers for scratches when changing the plunger seals. Scratched plungers will lead to micro leaks and will decrease the lifetime of the seal.
- Pressurize the system according to the wear in procedure after changing the plunger seals (see ["Exchanging the Pump Seals and Seal Wear-in Procedure"](#) on page 111).

## Solvent Information

Always filter solvents through 0.4 µm filters, small particles can permanently block the capillaries and valves. Avoid the use of the following steel-corrosive solvents:

- Solutions of alkali halides and their respective acids (for example, lithium iodide, potassium chloride, and so on).
- High concentrations of inorganic acids like sulfuric acid, especially at higher temperatures (replace, if your chromatography method allows, by phosphoric acid or phosphate buffer which are less corrosive against stainless steel).
- Halogenated solvents or mixtures which form radicals and/or acids, for example:

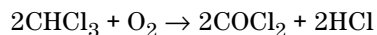

This reaction, in which stainless steel probably acts as a catalyst, occurs quickly with dried chloroform if the drying process removes the stabilizing alcohol.

- Chromatographic grade ethers, which can contain peroxides (for example, THF, dioxane, di-isopropylether) such ethers should be filtered through dry aluminium oxide which adsorbs the peroxides.
- Mixtures of carbon tetrachloride with 2-propanol or THF dissolve stainless steel.

### Prevent Blocking of Solvent Filters

Contaminated solvents or algae growth in the solvent bottle will reduce the lifetime of the solvent filter and will influence the performance of the pump. This is especially true for aqueous solvents or phosphate buffers (pH 4 to 7). The following suggestions will prolong lifetime of the solvent filter and will maintain the performance of the pump:

- Use sterile, if possible amber, solvent bottles to slow down algae growth.
- Filter solvents through filters or membranes that remove algae.
- Exchange solvents every two days or refilter.
- If the application permits add 0.0001–0.001 M sodium azide to the solvent.
- Place a layer of argon on top of your solvent.
- Avoid exposure of the solvent bottles to direct sunlight.

#### Checking the Solvent Filters

The solvent filters are on the low-pressure side of the pumping system. A blocked filter therefore does not affect the pressure readings of the pump. The pressure readings cannot be used to identify blocked filters. If the solvent cabinet is placed on top of the vacuum degasser the filter condition can be checked in the following way:

Remove the tubing at the inlet port of the vacuum degasser. If the filter is in good condition the solvent will freely drip out of the solvent tube (due to hydrostatic pressure). If the solvent filter is partly blocked no solvent or only very little solvent will drip out of the solvent tube.

### Cleaning the Solvent Filters

- Remove the blocked solvent filter from the bottle-head assembly and place it in a beaker with concentrated nitric acid (35%) for one hour.
- Thoroughly flush the filter with bidistilled water (remove all nitric acid, some capillary columns can be damaged by nitric acid).
- Replace the filter.

**NOTE**

Never use the system without solvent filter installed.

---

# Operational Hints for the Vacuum Degasser

### Operational Hints for the Vacuum Degasser

If you are using the vacuum degasser for the first time, if the vacuum degasser was switched off for any length of time (for example, overnight), or if the vacuum degasser lines are empty, you should prime the vacuum degasser before running an analysis.

The vacuum degasser can be primed either by drawing solvent through the degasser with a syringe or by pumping with the quaternary pump.

Priming the degasser with a syringe is recommended, when:

- vacuum degasser is used for the first time, or vacuum tubes are empty, or
- changing to solvents that are immiscible with the solvent currently in the vacuum tubes.

Priming the vacuum degasser by using the quaternary pump at high flow rate is recommended, when:

- quaternary pump was turned off for a length of time (for example, during night) and volatile solvent mixtures are used, or
- solvents have been changed.

For more information see the *Reference Manual* for the Agilent 1100 Series vacuum degasser.

## Operational Hints for the Multi Channel Gradient Valve (MCGV)

In a mixture of salt solutions and organic solvent the salt solution might be well dissolved in the organic solvent without showing precipitations. However in the mixing point of the gradient valve, at the boundary between the two solvents, micro precipitation is possible. Gravity forces the salt particles to fall down. Normally the A channel of the valve is used for the aqueous/salt solution and the B channel of the pump is used for the organic solvent. If used in this configuration the salt will fall back into the salt solution and will be dissolved. When using the pump in a different configuration (e.g., D - salt solution, A -organic solvent) the salt can fall into the port of the organic solvent and may lead to performance problems.

### NOTE

When using salt solutions and organic solvents in the Agilent 1100 Quaternary Pump it is recommended to connect the salt solution to one of the bottom ports and the organic solvent to one of the upper gradient valve ports. It is best to have the organic channel directly above the salt solution channel. Regular flushing with water of all MCGV channels is recommended to remove all possible salt deposits in the valve ports.

---

### When to use the Continuous Seal Wash Option

Highly-concentrated buffer solutions will reduce the lifetime of the seals and plungers in your quaternary pump. The seal wash option allows to maintain the seal lifetime by flushing the back side of the seal with a wash solvent.

The continuous seal wash option is strongly recommended when buffer concentrations of 0.1 Molar or higher will be used for long time periods in the quaternary pump.

The continuous seal wash option can be ordered by quoting part number 01018-68722 (kit contains parts for one pump head).

The seal wash option comprises a support ring, secondary seal, gasket and seal keeper for both plunger sides. A wash bottle filled with water /isopropanol (90/10) should be placed above the quaternary pump in the solvent cabinet and gravity will maintain a flow through the pump head removing all possible buffer crystals from the back of the pump seal.

#### NOTE

**Running dry is the worst case for a seal and drastically reduces its lifetime.**

The seal will build up sticky layers on the surface of the plunger. These sticky layers will also reduce the lifetime of the primary seal. Therefore the tubes of the wash option should always be filled with solvent to prolong the lifetime of the wash seal. Always use a mixture of bidistilled water (90%) and isopropanol (10%) as wash solvent. This mixture prevents bacteria growth in the wash bottle and reduces the surface tension of the water. The flow rate should be regulated to approximately 20 drops/minute. This can be done with the velocity regulator supplied with the accessory kit.

---

For information on the installation of the continuous seal wash option refer to "[Installing the Continuous Seal Wash Option](#)" on page 116.



## When to Use Alternative Seals

The standard seal for the quaternary pump can be used for most applications. However applications that use normal phase solvents (for example, hexane) are not suited for the standard seal and require a different seal when used for a longer time in the quaternary pump.

For applications that use normal phase solvents (for example, hexane) we recommend the use of the polyethylene seals, part number 0905-1420 (pack of 2). These seals have less abrasion compared to the standard seals.

### NOTE

Polyethylene seals have a limited pressure range 0–200 bar. When used above 200 bar their lifetime will be significantly reduced. **DO NOT** apply the seal wear-in procedure performed with new standard seals at 400 bar.

---

### Optimize the Compressibility Compensation Setting

The compressibility compensation default setting is  $100 \times 10^{-6}$  /bar for the quaternary pump. This setting represents an average value. Under normal conditions the default setting reduces the pressure pulsation to values (below 1% of system pressure) that will be sufficient for most applications and for all gradient analyses. For applications using sensitive detectors, the compressibility settings can be optimized by using the values for the various solvents described in [Table 6](#). If the solvent in use is not listed in the compressibility tables, when using isocratic mixtures of solvents and if the default settings are not sufficient for your application the following procedure can be used to optimize the compressibility settings.

#### NOTE

When using mixtures of solvents it is not possible to calculate the compressibility of the mixture by interpolating the compressibility values of the pure solvents used in that mixture or by applying any other calculation. In these cases the following empirical procedure has to be applied to optimize your compressibility setting.

- 1 Start the quaternary pump with the required flow rate.
- 2 Before starting the optimization procedure, the flow must be stable. Use degassed solvent only. Check the tightness of the system with the pressure test (see "[Pressure Test](#)" on page 84).
- 3 Your pump must be connected to a Chemstation or a handheld controller, the pressure and %-ripple can be monitored with one of these instruments,

otherwise connect a signal cable between the pressure output of the quaternary pump and a recording device (for example, 339X integrator) and set parameters.

Zero 50%

Att 2<sup>3</sup>

Chart Speed 10 cm/min

- 4 Start the recording device with the plot mode.

- 5 Starting with a compressibility setting of  $10 \times 10^{-6}$  /bar increase the value in steps of 10. Re-zero the integrator as required. The compressibility compensation setting that generates the smallest pressure ripple is the optimum value for your solvent composition.

**Table 6** Solvent Compressibility

Solvent (pure)	Compressibility ( $10^{-6}$ /bar)
Acetone	126
Acetonitrile	115
Benzene	95
Carbon tetrachloride	110
Chloroform	100
Cyclohexane	118
Ethanol	114
Ethyl acetate	104
Heptane	120
Hexane	150
Isobutanol	100
Isopropanol	100
Methanol	120
1-Propanol	100
Toluene	87
Water	46

## **2 Optimizing Performance**



## 3 Troubleshooting and Test Functions

Overview of the Pump's Indicators and Test Functions 46

Status Indicators 47

Error Messages 49

Pressure Test 84

Leak Test 89



## Overview of the Pump's Indicators and Test Functions

### Status Indicators

The quaternary pump is provided with two status indicators which indicate the operational state (prerun, run, and error states) of the quaternary pump. The status indicators provide a quick visual check of the operation of the quaternary pump (see "[Status Indicators](#)" on page 47).

### Error Messages

In the event of an electronic, mechanical or hydraulic failure, the quaternary pump generates an error message in the user interface. The following pages describe the meaning of the error messages. For each message, a short description of the failure, a list of probable causes of the problem, and a list of suggested actions to fix the problem are provided (see "[Error Messages](#)" on page 49).

### Pressure Test

The pressure test is a quick test designed to determine the pressure tightness of the system. After exchanging flow path components (e.g. pump seals or injection seal), use this test to verify the system is pressure tight up to 400 bar (see "[Pressure Test](#)" on page 84).

### Leak Test

The leak test is a diagnostic test designed to determine the pressure tightness of the quaternary pump. When a problem with the quaternary pump is suspected, use this test to help troubleshoot the quaternary pump and its pumping performance. The following sections describe these functions in detail (see "[Leak Test](#)" on page 89).

## Status Indicators

Two status indicators are located on the front of the quaternary pump. The lower left one indicates the power supply status, the upper right one indicates the quaternary pump status.

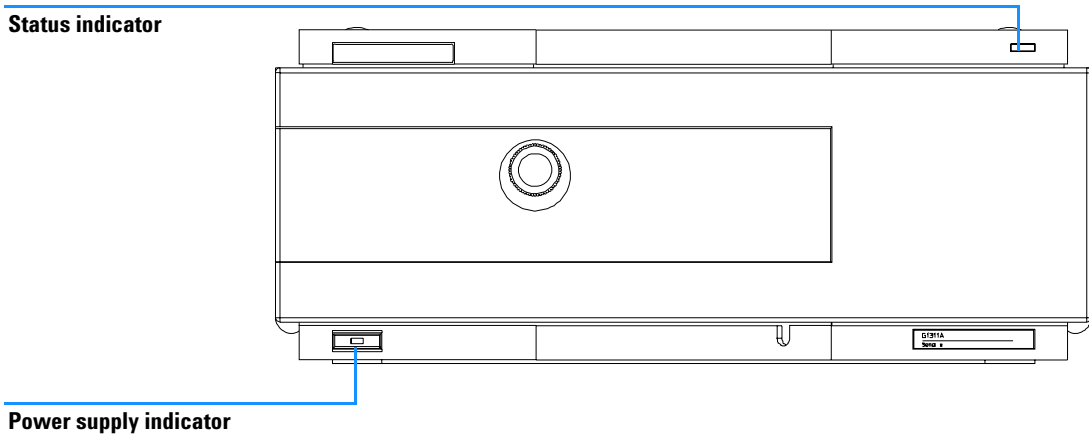

**Figure 7** Location of Status Indicators

### Power Supply Indicator

The power supply indicator is integrated into the main power switch. When the indicator is illuminated (*green*) the power is ON.

When the indicator is off, the module is turned OFF. Otherwise check power connections, availability of power or check functioning of the power supply.

## Pump Status Indicator

The Pump status indicator indicates one of four possible instrument conditions:

- When the status indicator is *OFF* (and power switch light is on), the quaternary pump is in a *prerun* condition, and is ready to begin an analysis.
- A *green* status indicator, indicates the quaternary pump is performing an analysis (*run mode*).
- A *yellow* indicator indicates a *not-ready* condition. The quaternary pump is in a not-ready state when it is waiting for a specific condition to be reached or completed (for example, immediately after changing a setpoint), or while a self-test procedure is running.
- An *error* condition is indicated when the status indicator is *red*. An error condition indicates the quaternary pump has detected an internal problem which affects correct operation of the quaternary pump. Usually, an error condition requires attention (for example, leak, defective internal components). An error condition always interrupts the analysis.
- A *flashing yellow* status indicator indicates that the module is in its *resident mode*. Call your local service provider for assistance upon observing this error condition.
- A *flashing red* status indicator indicates a severe error during the *startup* procedure of the module. Call your local service provider for assistance upon observing this error condition.



## Error Messages

Error messages are displayed in the user interface when an electronic, mechanical, or hydraulic (flow path) failure occurs which requires attention before the analysis can be continued (for example, repair, frit exchange or exchange of consumables required). In the event of such a failure, the red status indicator at the front of the quaternary pump is switched on, and an entry is written into the instrument logbook.

## Timeout

The timeout threshold was exceeded.

### Probable Causes

- The analysis was completed successfully, and the timeout function switched off the quaternary pump as requested.
- A not-ready condition was present during a sequence or multiple-injection run for a period longer than the timeout threshold.

### Suggested Actions

- ✓ Check the logbook for the occurrence and source of a not-ready condition. Restart the analysis where required.

## Shut-Down

An external instrument has generated a shut-down signal on the remote line.

The quaternary pump continually monitors the remote input connectors for status signals. A LOW signal input on pin 4 of the remote connector generates the error message.

### Probable Causes

- Leak detected in another module with a CAN connection to the system .
- Leak detected in an external instrument with a remote connection to the system.
- Shut-down in an external instrument with a remote connection to the system.
- The degasser failed to generate sufficient vacuum for solvent degassing.

### Suggested Actions

- ✓ Fix the leak in the external instrument before restarting the quaternary pump.
- ✓ Check external instruments for a shut-down condition.
- ✓ Check the vacuum degasser for an error condition. Refer to the *Reference Manual* for the Agilent 1100 Series vacuum degasser.

## Remote Timeout

A not-ready condition is still present on the remote input .

When an analysis is started, the system expects all not-ready conditions (e.g. a not-ready condition during detector balance) to switch to run conditions within one minute of starting the analysis. If a not-ready condition is still present on the remote line after one minute the error message is generated.

### Probable Causes

- Not-ready condition in one of the instruments connected to the remote line.
- Defective remote cable.
- Defective components in the instrument showing the not-ready condition.

### Suggested Actions

- ✓ Ensure the instrument showing the not-ready condition is installed correctly, and is set up correctly for analysis.
- ✓ Exchange the remote cable.
- ✓ Check the instrument for defects (refer to the instrument's reference documentation).

## Synchronization Lost

During an analysis, the internal synchronization or communication between one or more of the modules in the system has failed.

The system processors continually monitor the system configuration. If one or more of the modules is no longer recognized as being connected to the system, the error message is generated.

### Probable Causes

- CAN cable disconnected.
- Defective CAN cable.
- Defective main board in another module.

### Suggested Actions

- ✓ Ensure all the CAN cables are connected correctly.
- ✓ Switch off the system. Restart the system, and determine which module or modules are not recognized by the system.
- ✓ Ensure all CAN cables are installed correctly.

## Leak

A leak was detected in the quaternary pump.

The signals from the two temperature sensors (leak sensor and board-mounted temperature-compensation sensor) are used by the leak algorithm to determine whether a leak is present. When a leak occurs, the leak sensor is cooled by the solvent. This changes the resistance of the leak sensor which is sensed by the leak-sensor circuit on the LPM board

### Probable Causes

- Loose fittings.
- Broken capillary.
- Loose or leaking purge valve, active inlet valve, or outlet ball valve.
- Defective pump seals.

### Suggested Actions

- ✓ Ensure all fittings are tight.
- ✓ Exchange defective capillaries.
- ✓ Ensure pump components are seated correctly. If there are still signs of a leak, exchange the appropriate seal (purge valve, active inlet valve, outlet ball valve).
- ✓ Exchange the pump seals.

## Leak Sensor Open

The leak sensor in the quaternary pump has failed (open circuit).

The current through the leak sensor is dependent on temperature. A leak is detected when solvent cools the leak sensor, causing the leak-sensor current to change within defined limits. If the current falls outside the lower limit, the error message is generated.

### Probable Causes

- Leak sensor not connected to the LPM board.
- Defective leak sensor.
- Leak sensor incorrectly routed, being pinched by a metal component.

### Suggested Actions

- ✓ Ensure the leak sensor is connected correctly.
- ✓ Exchange the leak sensor.

## Leak Sensor Short

The leak sensor in the quaternary pump has failed (short circuit).

The current through the leak sensor is dependent on temperature. A leak is detected when solvent cools the leak sensor, causing the leak-sensor current to change within defined limits. If the current increases above the upper limit, the error message is generated.

### Probable Causes

- Defective leak sensor.
- Leak sensor incorrectly routed, being pinched by a metal component.

### Suggested Actions

- ✓ Exchange the leak sensor.



## Compensation Sensor Open

The ambient-compensation sensor (NTC) on the LPM board in the quaternary pump has failed (open circuit).

The resistance across the temperature compensation sensor (NTC) on the LPM board is dependent on ambient temperature. The change in resistance is used by the leak circuit to compensate for ambient temperature changes. If the resistance across the sensor increases above the upper limit, the error message is generated.

### Probable Causes

- Defective LPM board.

### Suggested Actions

- ✓ Exchange the LPM board.

## Compensation Sensor Short

The ambient-compensation sensor (NTC) on the LPM board in the quaternary pump has failed (short circuit).

The resistance across the temperature compensation sensor (NTC) on the LPM board is dependent on ambient temperature. The change in resistance is used by the leak circuit to compensate for ambient temperature changes. If the resistance across the sensor falls below the lower limit, the error message is generated.

### Probable Causes

- Defective LPM board.

### Suggested Actions

- ✓ Exchange the LPM board.

## Fan Failed

The cooling fan in the quaternary pump has failed.

The hall sensor on the fan shaft is used by the LPM board to monitor the fan speed. If the fan speed falls below 2 revolutions/second for longer than 5 seconds, the error message is generated.

### Probable Causes

- Fan cable disconnected.
- Defective fan.
- Defective LPM board.
- Improperly positioned cables or wires obstructing fan blades.

### Suggested Actions

- ✓ Ensure the fan is connected correctly.
- ✓ Exchange fan.
- ✓ Exchange the LPM board.
- ✓ Ensure the fan is not mechanically blocked.

### Open Cover

The top foam has been removed.

The sensor on the LPM board detects when the top foam is in place. If the foam is removed, the fan is switched off, and the error message is generated.

#### Probable Causes

- The top foam was removed during operation.
- Foam not activating the sensor.
- Sensor defective.
- Rear of the module is exposed to strong direct sunlight.

#### Suggested Actions

- ✓ Replace the top foam.
- ✓ Exchange the LPM board.
- ✓ Ensure that the rear of module is not directly exposed to strong sunlight.

## Restart Without Cover

The quaternary pump was restarted with the top cover and foam open.

The sensor on the LPM board detects when the top foam is in place. If the quaternary pump is restarted with the foam removed, the quaternary pump switches off within 30 s, and the error message is generated.

### Probable Causes

- The quaternary pump started with the top cover and foam removed.
- Rear of the module is exposed to strong direct sunlight.

### Suggested Actions

- ✓ Replace the top cover and foam.
- ✓ Ensure that the rear of module is not directly exposed to strong sunlight.

## Zero Solvent Counter

Pump firmware version A.02.32 and higher allow to set solvent bottle fillings at the ChemStation (revision 5.xx and higher). If the volume level in the bottle falls below the specified value the error message appears when the feature is configured accordingly.

### Probable Causes

- Volume in bottle below specified volume.
- Incorrect setting of limit.

### Suggested Actions

- ✓ Refill bottles and reset solvent counters.

## Pressure Above Upper Limit

The system pressure has exceeded the upper pressure limit.

### Probable Causes

- Upper pressure limit set too low.
- Blockage in the flowpath (after the damper).
- Defective damper.
- Defective LPM board.

### Suggested Actions

- ✓ Ensure the upper pressure limit is set to a value suitable for the analysis.
- ✓ Check for blockage in the flowpath. The following components are particularly subject to blockage:
  - purge-valve frit.
  - needle (autosampler),
  - seat capillary (autosampler),
  - sample loop (autosampler), and
  - column frits.
  - capillaries with low internal diameters (e.g. 0.12mm id).
- ✓ Exchange the damper.
- ✓ Exchange the LPM board.

## Pressure Below Lower Limit

The system pressure has fallen below the lower pressure limit.

### Probable Causes

- Lower pressure limit set too high.
- Air bubbles in the mobile phase.
- Leak.
- Defective damper.
- Defective LPM board.

### Suggested Actions

- ✓ Ensure the lower pressure limit is set to a value suitable for the analysis.
- ✓ Ensure solvents are degassed. Purge the quaternary pump.
- ✓ Ensure solvent inlet filters are not blocked.
- ✓ Inspect the pump head, capillaries and fittings for signs of a leak.
- ✓ Purge the quaternary pump. Run a pressure test to determine whether the seals or other pump components are defective.
- ✓ Exchange the damper.
- ✓ Exchange the LPM board.



## Pressure Signal Missing

The pressure signal from the damper is missing.

The pressure signal from the damper must be within a specific voltage range. If the pressure signal is missing, the processor detects a voltage of approximately -120mV across the damper connector.

### Probable Causes

- Damper disconnected.
- Defective damper.

### Suggested Actions

- ✓ Ensure the damper is connected correctly to the LPM board.
- ✓ Exchange the damper.

### Missing Pressure Reading

The pressure readings read by the pump ADC (analog-digital converter) are missing.

The ADC reads the pressure readings from the damper every 1ms. If the readings are missing for longer than 10 seconds, the error message is generated.

#### Probable Causes

- Damper not connected.
- Defective damper.
- Defective LPM board.

#### Suggested Actions

- ✓ Ensure the damper is connected, clean and seated correctly.
- ✓ Exchange the damper.
- ✓ Exchange the LPM board.

## Pump Configuration

At switch-on, the quaternary pump has recognized a new pump configuration.

The quaternary pump is assigned its configuration at the factory. If the gradient valve is disconnected, and the quaternary pump is rebooted, the error message is generated. *However, the pump will function as an isocratic pump in this configuration.* The error message reappears after each switch-on.

### Probable Causes

- Gradient valve disconnected.

### Suggested Actions

- ✓ Reconnect the gradient valve.

### Valve Fuse

**Valve Fuse 0:** Channels A and B

**Valve Fuse 1:** Channels C and D

The gradient valve in the quaternary pump has drawn excessive current causing the electronic fuse to open.

#### Probable Causes

- Defective gradient valve.
- Defective connection cable (front panel to LPM board).
- Defective LPM board.

#### Suggested Actions

- ✓ Restart the quaternary pump. If the error message appears again, exchange the gradient valve.
- ✓ Exchange the connection cable.
- ✓ Exchange the LPM board.

## Inlet-Valve Fuse

The active-inlet valve in the quaternary pump has drawn excessive current causing the inlet-valve electronic fuse to open.

### Probable Causes

- Defective active inlet valve.
- Defective connection cable (front panel to LPM board).
- Defective LPM board.

### Suggested Actions

- ✓ Restart the quaternary pump. If the error message appears again, exchange the active inlet valve.
- ✓ Exchange the connection cable.
- ✓ Exchange the LPM board.

### Valve Failed

**Valve 0 Failed:** valve A

Valve 1 Failed: valve B

Valve 2 Failed: valve C

Valve 3 Failed: valve D

One of the valves of the multi-channel gradient valve has failed to switch correctly.

The processor monitors the valve voltage before and after each switching cycle. If the voltages are outside expected limits, the error message is generated.

#### Probable Causes

- Gradient valve disconnected.
- Connection cable (inside instrument) not connected.
- Connection cable (inside instrument) defective.
- Gradient valve defective.

#### Suggested Actions

- ✓ Ensure the gradient valve is connected correctly.
- ✓ Ensure the connection cable is connected correctly.
- ✓ Exchange the connection cable.
- ✓ Exchange the gradient valve.

## Motor-Drive Power

The current drawn by the pump motor exceeded the maximum limit.

Blockages in the flow path are usually detected by the pressure sensor in the damper, which result in the pump switching off when the upper pressure limit is exceeded. If a blockage occurs before the damper, the pressure increase cannot be detected by the pressure sensor and the quaternary pump will continue to pump. As pressure increases, the pump drive draws more current. When the current reaches the maximum limit, the quaternary pump is switched off, and the error message is generated.

### Probable Causes

- Flow path blockage in front of the damper.
- Blocked active inlet valve.
- Blocked outlet ball valve.
- High friction (partial mechanical blockage) in the pump drive assembly.
- Defective pump drive assembly.
- Defective LPM board.

### Suggested Actions

- ✓ Ensure the capillaries and frits between the pump head and damper inlet are free from blockage.
- ✓ Exchange the active inlet valve.
- ✓ Exchange the outlet ball valve.
- ✓ Remove the pump-head assembly. Ensure there is no mechanical blockage of the pump-head assembly or pump drive assembly.
- ✓ Exchange the pump drive assembly.
- ✓ Exchange the LPM board.

### Encoder Missing

The optical encoder on the pump motor in the quaternary pump is missing or defective.

The processor checks the presence of the pump encoder connector every 2 seconds. If the connector is not detected by the processor, the error message is generated.

#### Probable Causes

- Defective or disconnected pump encoder connector.
- Defective pump drive assembly.

#### Suggested Actions

- ✓ Ensure the connector is clean, and seated correctly.
- ✓ Exchange the pump drive assembly.



## Inlet-Valve Missing

The active-inlet valve in the quaternary pump is missing or defective.

The processor checks the presence of the active-inlet valve connector every 2 seconds. If the connector is not detected by the processor, the error message is generated.

### Probable Causes

- Disconnected or defective cable.
- Disconnected or defective connection cable (front panel to LPM board).
- Defective active inlet valve.

### Suggested Actions

- ✓ Ensure the pins of the active inlet valve connector are not damaged. Ensure the connector is seated securely.
- ✓ Ensure the connection cable is seated correctly. Exchange the cable if defective.
- ✓ Exchange the active inlet valve.

### Temperature Out of Range

The temperature sensor readings in the motor-drive circuit are out of range.

The values supplied to the ADC by the hybrid sensors must be between 0.5 V and 4.3 V. If the values are outside this range, the error message is generated.

#### Probable Causes

- Defective LPM board.

#### Suggested Actions

- ✓ Exchange the LPM board.

## Temperature Limit Exceeded

The temperature of one of the motor-drive circuits is too high.

The processor continually monitors the temperature of the drive circuits on the LPM board. If excessive current is being drawn for long periods, the temperature of the circuits increases. If the temperature exceeds the upper limit of 95 °C, the error message is generated.

### Probable Causes

- High friction (partial mechanical blockage) in the pump drive assembly.
- Partial blockage of the flowpath in front of the damper.
- Defective pump drive assembly.
- Defective LPM board.

### Suggested Actions

- ✓ Ensure the capillaries and frits between the pump head and damper inlet are free from blockage.
- ✓ Ensure the outlet valve is not blocked.
- ✓ Remove the pump head assembly. Ensure there is no mechanical blockage of the pump head assembly or pump drive assembly.
- ✓ Exchange the pump drive assembly.
- ✓ Exchange the LPM board.

## Servo Restart Failed

The pump motor in the quaternary pump was unable to move into the correct position for restarting.

When the quaternary pump is switched on, the first step is to switch on the C phase of the variable reluctance motor. The rotor should move to one of the C positions. The C position is required for the servo to be able to take control of the phase sequencing with the commutator. If the rotor is unable to move, or if the C position cannot be reached, the error message is generated.

### Probable Causes

- Disconnected or defective cables.
- Blocked active inlet valve.
- Mechanical blockage of the quaternary pump.
- Defective pump drive assembly.
- Defective LPM board.

### Suggested Actions

- ✓ Ensure the pump-assembly cables are not damaged or dirty. Make sure the cables are connected securely to the LPM board.
- ✓ Exchange the active inlet valve.
- ✓ Remove the pump-head assembly. Ensure there is no mechanical blockage of the pump-head assembly or pump drive assembly.
- ✓ Exchange the pump drive assembly.
- ✓ Exchange the LPM board.

## Pump Head Missing

The pump-head end stop in the quaternary pump was not found.

When the quaternary pump restarts, the metering drive moves forward to the mechanical end stop. Normally, the end stop is reached within 20 seconds, indicated by an increase in motor current. If the end point is not found within 20 seconds, the error message is generated.

### Probable Causes

- Pump head not installed correctly (screws not secured, or pump head not seated correctly).
- Broken plunger.

### Suggested Actions

- ✓ Install the pump head correctly. Ensure nothing (e.g. capillary) is trapped between the pump head and body.
- ✓ Exchange the plunger.

### Index Limit

The time required by the plunger to reach the encoder index position was too short (quaternary pump).

During initialization, the first plunger is moved to the mechanical stop. After reaching the mechanical stop, the plunger reverses direction until the encoder index position is reached. If the index position is reached too fast, the error message is generated.

#### Probable Causes

- Irregular or sticking drive movement.
- Defective pump drive assembly.

#### Suggested Actions

- ✓ Remove the pump head, and examine the seals, plungers, and internal components for signs of wear, contamination or damage. Exchange components as required.
- ✓ Exchange the pump drive assembly.

## Index Adjustment

The encoder index position in the quaternary pump is out of adjustment.

During initialization, the first plunger is moved to the mechanical stop. After reaching the mechanical stop, the plunger reverses direction until the encoder index position is reached. If the time to reach the index position is too long, the error message is generated.

### Probable Causes

- Irregular or sticking drive movement.
- Defective pump drive assembly.

### Suggested Actions

- ✓ Remove the pump head, and examine the seals, plungers, and internal components for signs of wear, contamination or damage. Exchange components as required.
- ✓ Exchange the pump drive assembly.

### Index Missing

The encoder index position in the quaternary pump was not found during initialization.

During initialization, the first plunger is moved to the mechanical stop. After reaching the mechanical stop, the plunger reverses direction until the encoder index position is reached. If the index position is not recognized within a defined time, the error message is generated.

#### Probable Causes

- Disconnected or defective encoder cable.
- Defective pump drive assembly.

#### Suggested Actions

- ✓ Ensure the encoder cable are not damaged or dirty. Make sure the cables are connected securely to the LPM board.
- ✓ Exchange the pump drive assembly.



## Stroke Length

The distance between the lower plunger position and the upper mechanical stop is out of limits (quaternary pump).

During initialization, the quaternary pump monitors the drive current. If the plunger reaches the upper mechanical stop position before expected, the motor current increases as the quaternary pump attempts to drive the plunger beyond the mechanical stop. This current increase causes the error message to be generated.

### Probable Causes

- Defective pump drive assembly.

### Suggested Actions

- ✓ Exchange the pump drive assembly.

### Initialization Failed

The quaternary pump failed to initialize successfully within the maximum time window.

A maximum time is assigned for the complete pump-initialization cycle. If the time is exceeded before initialization is complete, the error message is generated.

#### Probable Causes

- Blocked active inlet valve.
- Defective pump drive assembly.
- Defective LPM board.

#### Suggested Actions

- ✓ Exchange the active inlet valve.
- ✓ Exchange the pump drive assembly.
- ✓ Exchange the LPM board.

## Wait Timeout

When running certain tests in the diagnostics mode or other special applications, the pump must wait for the plungers to reach a specific position, or must wait for a certain pressure or flow to be reached. Each action or state must be completed within the timeout period, otherwise the error message is generated.

### Possible Reasons for a Wait Timeout

- Pressure not reached.
- Pump channel A did not reach the delivery phase.
- Pump channel B did not reach the delivery phase.
- Pump channel A did not reach the take-in phase.
- Pump channel B did not reach the take-in phase.
- Solvent volume not delivered within the specified time.

### Probable Causes

- Purge valve still open.
- Leak at fittings, purge valve, active inlet valve, outlet ball valve or plunger seals.
- Flow changed after starting test.
- Defective pump drive assembly.

### Suggested Actions

- ✓ Ensure that purge valve is closed.
- ✓ Exchange defective capillaries.
- ✓ Ensure pump components are seated correctly. If there are still signs of a leak, exchange the appropriate seal (purge valve, active inlet valve, outlet ball valve, plunger seal).
- ✓ Ensure correct operating condition for the special application in use.
- ✓ Exchange the defective pump drive assembly.

## Pressure Test

### Description

The pressure test is a quick, built-in test designed to demonstrate the pressure-tightness of the system. The test should be used when problems with small leaks are suspected, or after maintenance of flow-path components (e.g. pump seals, injection seal) to prove pressure tightness up to 400 bar. The test involves monitoring the pressure profile as the pump runs through a predefined pumping sequence. The resulting pressure profile provides information about the pressure tightness of the system.

The column compartment outlet (or the outlet of the last module before the detector) is blocked with a blank nut, and then the test is run using isopropyl alcohol (IPA), while monitoring the pressure profile (using an integrator on the analog output, or in the plot screen in the ChemStation). The pressure profile is shown in [Figure 8](#).

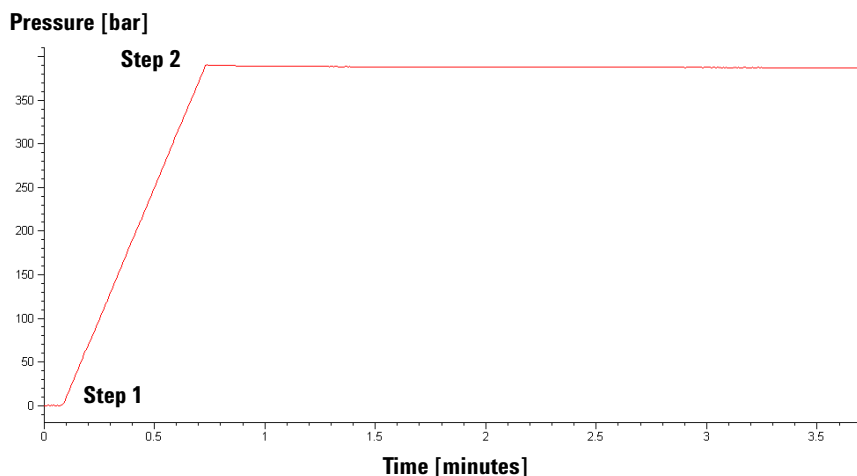

**Figure 8** Typical Pressure-Test Pressure Profile with IPA

**Step 1**

The test begins with the initialization of the pump. After initialization, plunger 1 is at the top of its stroke. Next, the pump begins pumping solvent with a flow rate of 510  $\mu\text{l}/\text{min}$  and stroke of 100  $\mu\text{l}$ . The pump continues to pump until a system pressure of 390 bar is reached.

**Step 2**

When the system pressure reaches 390 bar, the pump switches off. The pressure drop from this point onwards should be no more than 2 bar/minute.

**Positioning the blank nut**

To test the complete system's pressure tightness, the blank nut should be positioned at the column compartment outlet (or the outlet of the last module before the detector).

If a specific component is suspected of causing a system leak, place the blank nut immediately before the suspected component, then run the pressure test again. If the test passes, the defective component is located after the blank nut. Confirm the diagnosis by placing the blank nut immediately after the suspected component. The diagnosis is confirmed if the test fails.

**Running the Pressure Test**

<b>Tools required</b>	¼-inch" wrench
<b>Parts and materials required</b>	Blank nut, 01080-83202
	Isopropanol, 500 ml

**Running the test from the ChemStation**

- 1 Select the pressure test from the test selection box in the Diagnosis screen.
- 2 Start the test and follow the instructions.

**NOTE**

Make absolutely sure that all parts of the flow path that are part of the test are very thoroughly flushed with IPA before starting to pressurize the system! Any trace of other solvents or the smallest air bubble inside the flow path definitely will cause the test to fail!

The slope and plateau are evaluated automatically. "[Evaluating the Results](#)" on page 87 describes the evaluation and interpretation of the pressure test results.

#### Running the test from the Control Module

- 1 Place a bottle of LC-grade isopropyl alcohol in channel D.
- 2 Block column compartment outlet (or the outlet of the last module before the detector) with a blank nut (01080-83202), "[Positioning the blank nut](#)" on page 85
- 3 Open the purge valve. Set flow for channel D to 5 ml/min and flush the degasser for about 10 minutes.
- 4 Set flow to 0 ml/min. *Leave the purge valve open.*
- 5 Connect the signal cable to the analog output at the rear of the pump module (only if an integrator is used).
- 6 Press Execute to initialize the pressure test.

Once the test is started, the pump moves the plungers into the start position. When the plungers are in position, the user interface prompts you to close the purge valve, and continue the test.

- 7 Close the purge valve, select *continue* on the control module and press *Enter* to start the test.

The control module displays a graphical representation of the pressure. "[Evaluating the Results](#)" on page 87 describes the evaluation and interpretation of the pressure test results.

- 8 When the test is finished slowly open the purge valve to release the pressure in the system.

## Evaluating the Results

The sum of all leaks between the pump and the blank nut will be indicated by a pressure drop of >2 bar/minute at the plateau. Note that small leaks may cause the test to fail, but solvent may not be seen leaking from a module.

### NOTE

Please notice the difference between an **error** in the test and a **failure** of the test! An **error** means that during the operation of the test there was an abnormal termination. If a test **failed**, this means that the results of the test were not within the specified limits.

---

### If the pressure test fails:

- Ensure all fittings between the pump and the blank nut are tight. Repeat the pressure test.

### NOTE

Often it is only a damaged blank nut itself (poorly shaped from overtightening) that causes a failure of the test. Before investigating on any other possible sources of failure make sure that the blank nut you are using is in good condition and properly tightened!

---

- If the test fails again, insert the blank nut at the outlet of the previous module in the stack (eg. autosampler, port 6 of the injection valve), and repeat the pressure test. Exclude each module one by one to determine which module is leaking.
- If the pump is determined to be the source of the leak, run the leak test.

## Potential Causes of Pressure Test Failure

After isolating and fixing the cause of the leak, repeat the pressure test to confirm the system is pressure tight.

Potential Cause (Pump)	Corrective Action
Purge valve open.	Close the purge valve.
Loose or leaky fitting.	Tighten the fitting or exchange the capillary.
Damaged pump seals or plungers.	Run the leak test to confirm the leak.
Loose purge valve.	Tighten the purge valve nut (14 mm wrench).

Potential Cause (Autosampler)	Corrective Action
Loose or leaky fitting.	Tighten or exchange the fitting or capillary.
Rotor seal (injection valve).	Exchange the rotor seal.
Damaged metering seal or plunger.	Exchange the metering seal. Check the plunger for scratches. Exchange the plunger if required.
Needle seat.	Exchange the needle seat.

Potential Cause (Column Compartment)	Corrective Action
Loose or leaky fitting.	Tighten or exchange the fitting or capillary.
Rotor seal (column switching valve).	Exchange the rotor seal.



## Leak Test

### Description

The leak test is a built-in troubleshooting test designed to demonstrate the leak-tightness of the pump. The test should be used when problems with the pump are suspected. The test involves monitoring the pressure profile as the pump runs through a predefined pumping sequence. The resulting pressure profile provides information about the pressure tightness and operation of the pump components.

The pump outlet is blocked with a blank nut, and then the test is run using isopropyl alcohol (IPA), while monitoring the pressure profile (using an integrator on the analog output, or in the plot screen in the Control Module or the ChemStation).

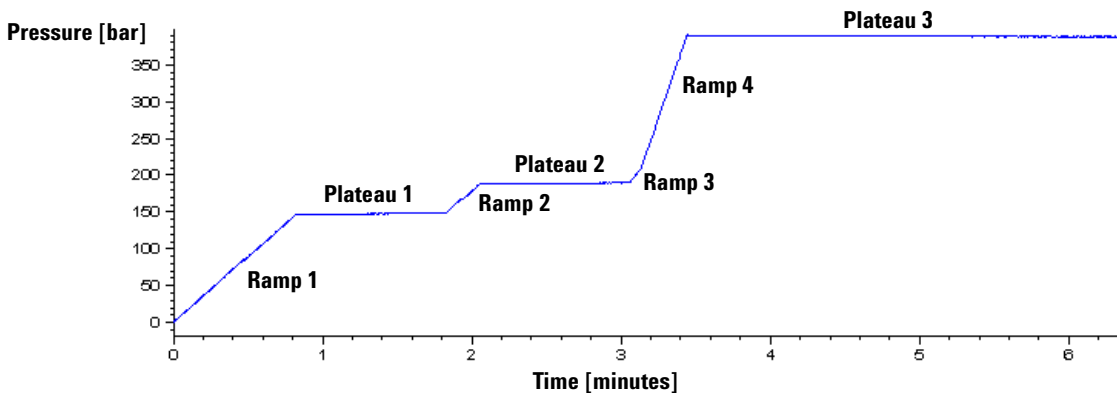

**Figure 9** Typical Leak-Test Pressure Profile with IPA

### Ramp 1:

After initialization, plunger 2 is at the top of its stroke. The test begins with plunger 1 delivering with a stroke length of 100 $\mu$ l and a flow of 153 $\mu$ l/min. The plunger sequence during the pressure ramp is 1-2-1-2. The pressure increase during this phase should be linear. Pressure disturbances during this phase indicate larger leaks or defective pump components.

### 3 Troubleshooting and Test Functions

#### **Plateau 1:**

plunger 2 continues to pump with a flow rate of 2 $\mu$ l/min for approximately one minute. The pressure during the plateau should remain constant or increase slightly. A falling pressure indicates a leak of >2 $\mu$ l/min.

#### **Ramp 2:**

The flow is changed to 153 $\mu$ l/min, and plunger 2 continues to deliver for the rest of its stroke. Then plunger 1 continues to pump to complete the second half of the ramp.

#### **Plateau 2:**

The flow is reduced to 2  $\mu$ l/min for approximately one minute (plunger 1 still delivering). The pressure during the plateau should remain constant or increase slightly. A falling pressure indicates a leak of >2  $\mu$ l/min.

#### **Ramp 3:**

The flow increases to 220 $\mu$ l/min and the stroke is changed to 100  $\mu$ l. Plunger 1 completes its stroke. Next, the flow is changed to 510 $\mu$ l/min. The ramp reaches 390 bar with the plunger sequence 2-1-2-1.

#### **Ramp 4:**

When the system pressure reaches 390 bar, the flow is reduced to zero, and the pressure stabilizes just below 400 bar.

#### **Plateau 3:**

1 min after reaching the maximum pressure, the pressure drop should not exceed 2 bar/min.

## Running the Leak Test

<b>Tools required</b>	¼ inch" wrench.
<b>Parts and materials required</b>	Restriction Capillary ,G1313-87305 Blank nut, 01080-83202 Isopropanol, 500 ml

### Running the test from the ChemStation

- 1 Select the leak test from the test selection box in the Diagnosis screen.
- 2 Start the test and follow the instructions.

#### NOTE

Make absolutely sure that all parts of the flow path that are part of the test are very thoroughly flushed with IPA before starting to pressurize the system! Any trace of other solvents or the smallest air bubble inside the flow path definitely will cause the test to fail!

The slopes and plateaus are evaluated automatically. "[Evaluating the Results](#)" on page 87 describes the evaluation and interpretation of the leak test results.

### Running the test from the Control Module

- 1 Place a bottle of LC-grade isopropyl alcohol in channel D.
- 2 Open the purge valve.
- 3 Set flow to 5 ml/min for channel D and flush the degasser channel for about 10minutes.
- 4 Turn off pump operation and close the purge valve.
- 5 Connect the restriction capillary (G1313-87305) to pump outlet.

The next steps are necessary to wear in new seals.

- 6 Set flow to 5 ml/min and flush the pump channel for about 3 minutes.
- 7 Set flow to 0 ml/min and replace the restriction capillary with blank nut (01080-83202).
- 8 Open the purge valve.
- 9 Connect the signal cable to the analog output at the rear of the pump module (only if an integrator is used).

### 3 Troubleshooting and Test Functions

**10** Press Execute to initialize the leak test.

Once the test is started, the pump moves the plungers into the start position. When the plungers are in position, the user interface prompts you to close the purge valve.

**11** Close the purge valve, select *continue* on the control module and press *Enter* to start the test.

The control module displays a graphical representation of the pressure in the plateau windows. "[Evaluating the Results](#)" on page 87 describes the evaluation and interpretation of the leak test results.

**12** When the test is finished slowly open the purge valve to release the pressure in the system.

## Evaluating the Results

Defective or leaky components in the pump head lead to changes in the leak-test pressure plot. Typical failure modes are described below.

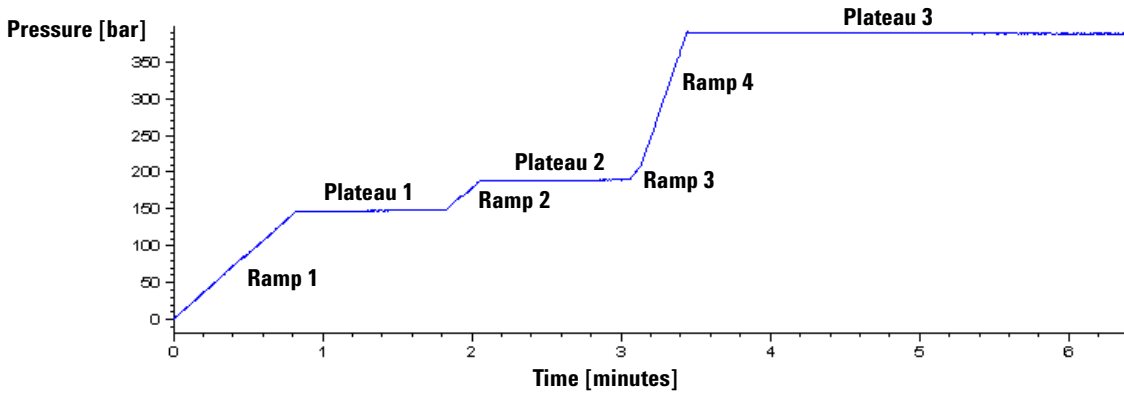

**Figure 10** Leak Test Pressure Profile

**NOTE**

Please notice the difference between an **error** in the test and a **failure** of the test! An **error** means that during the operation of the test there was an abnormal termination. If a test **failed**, this means that the results of the test were not within the specified limits.

**NOTE**

Often it is only a damaged blank nut itself (poorly shaped from overtightening) that causes a failure of the test. Before investigating on any other possible sources of failure make sure that the blank nut you are using is in good condition and properly tightened!

### No Pressure increase at Ramp 1

Potential Cause	Corrective Action
Pump not running.	Check the logbook for error messages.
Purge valve open.	Close the purge valve, and restart the test.
Loose or leaky fittings.	Ensure all fittings are tight, or exchange capillary.

### 3 Troubleshooting and Test Functions

Wrong solvent-line connections.	Ensure the solvent lines from the degasser are connected correctly (channel D for quaternary pump).
Contaminated purge valve.	Open and close purge valve to flush out contamination. Exchange the valve if still leaky.
Large leaks (visible) at the pump seals.	Exchange the pump seals.
Large leaks (visible) at active inlet valve, outlet valve, or purge valve.	Ensure the leaky components are installed tightly. Exchange the component if required.

---

#### Pressure limit not reached but plateaus horizontal or positive

---

Potential Cause	Corrective Action
Degasser and pump not flushed sufficiently (air in the pump head).	Purge the degasser and pump thoroughly with isopropanol under pressure (use the restriction capillary).
Wrong solvent.	Install isopropanol. Purge the degasser and pump thoroughly.

---

#### All plateaus negative

---

Potential Cause	Corrective Action
Loose or leaky fittings.	Ensure all fittings are tight, or exchange capillary.
Loose purge valve.	Tighten the purge valve (14mm wrench).
Contaminated purge valve.	Open and close purge valve to flush out contamination. Exchange the valve if still leaky.
Loose pump head screws.	Ensure the pump head screws are tight.
Leaking seals or scratched plungers.	Exchange the pump seals. Check the plungers for scratches. Exchange if scratched.
Leaking outlet valve.	Exchange the outlet valve.
Leaky damper.	Exchange damper.

---

**First plateau positive, second and third plateau negative**

Potential Cause	Corrective Action
Air in pump or new seals not yet seated.	Flush pump thoroughly with isopropanol under pressure (use restriction capillary).
Loose active inlet valve.	Tighten the active inlet valve (14mm wrench). Do not overtighten!
Loose pump head screws.	Ensure the pump head screws are tight.
Loose outlet valve.	Ensure the sieve in the outlet valve is installed correctly. Tighten the outlet valve.
Leaking seal or scratched plunger.	Exchange the pump seals. Check the plungers for scratches. Exchange if scratched.
Defective active inlet valve.	Exchange the active inlet valve.

**First plateau negative, second plateau positive**

Potential Cause	Corrective Action
Leaking outlet valve.	Clean the outlet valve. Ensure the sieve in the outlet valves are installed correctly. Tighten the outlet valve.
Loose pump head screws.	Ensure the pump head screws are tight.
Leaking seals or scratched plungers.	Exchange the pump seals. Check the plunger for scratches. Exchange if scratched.

**Ramp 3 does not reach limit**

Potential Cause	Corrective Action
Pump stopped due to error.	Check the logbook for error messages.
Large leaks (visible) at the pump seals.	Exchange the pump seals.
Large leaks (visible) at active inlet valve, outlet valve, or purge valve.	Ensure the leaky components are installed tightly. Exchange the component if required.

#### Third plateau negative (pressure drop > 2 bar/min)

Potential Cause	Corrective Action
Loose or leaky fittings.	Ensure all fittings are tight, or exchange capillary.
Loose purge valve.	Tighten the purge valve (14mm wrench).
Contaminated purge valve.	Open and close purge valve to flush out contamination. Exchange the valve if still leaky.
Loose pump head screws.	Ensure the pump head screws are tight.
Leaking seals or scratched plungers.	Exchange the pump seals. Check the plungers for scratches. Exchange if scratched.
Leaking outlet valve.	Exchange the outlet valve.
Leaky damper.	Exchange damper.



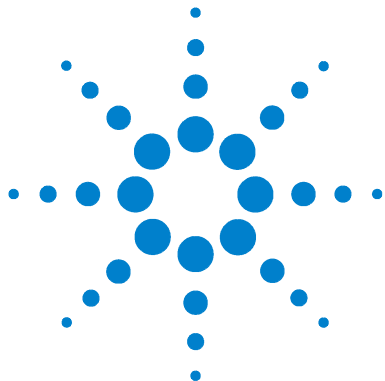

## 4 Repairing the Pump

Introduction into Repairing the Pump	98
Overview of the Repairing the Pump	100
Simple Repair Procedures	101



# Introduction into Repairing the Pump

### Simple Repairs

The quaternary pump is designed for easy repair. The most frequent repairs such as plunger seal change and purge valve frit change can be done from the front of the quaternary pump with the quaternary pump in place in the system stack. These repairs are described in "[Simple Repair Procedures](#)" on page 101.

#### **WARNING**

**When opening capillary or tube fittings solvents may leak out. Please observe appropriate safety procedures (for example, goggles, safety gloves and protective clothing) as described in the material handling and safety data sheet supplied by the solvent vendor, especially when toxic or hazardous solvents are used.**

---

### Exchanging Internal Parts

Some repairs may require exchange of defective internal parts. Exchange of these parts requires removing the quaternary pump from the stack, removing the covers, and disassembling the quaternary pump. The security lever at the power input socket prevents that the pump cover is taken off when line power is still connected.

#### **WARNING**

**To prevent personal injury, the power cable must be removed from the quaternary pump before opening the pump cover. Do not connect the power cable to the quaternary pump while the covers are removed.**

---

#### **CAUTION**

Electronic boards and components are sensitive to electrostatic discharge (ESD). In order to prevent damage always use an ESD protection (for example, the ESD wrist strap from the accessory kit) when handling electronic boards and components.

---

## Cleaning the Quaternary Pump

The quaternary pump case should be kept clean. Cleaning should be done with a soft cloth slightly dampened with water or a solution of water and a mild detergent. Do not use an excessively damp cloth that liquid can drip into the quaternary pump.

### WARNING

**Do not let liquid drip into the quaternary pump. It could cause shock hazard and it could damage the quaternary pump.**

---

## Using the ESD Strap

Electronic boards are sensitive to electronic discharge (ESD). In order to prevent damage, always use an ESD strap supplied in the standard accessory kit (see "[Accessory Kit G1311-68705](#)" on page 181) when handling electronic boards and components.

- 1 Unwrap the first two folds of the band and wrap the exposed adhesive side firmly around your wrist.
- 2 Unroll the rest of the band and peel the liner from the copper foil at the opposite end.
- 3 Attach the copper foil to a convenient and exposed electrical ground.

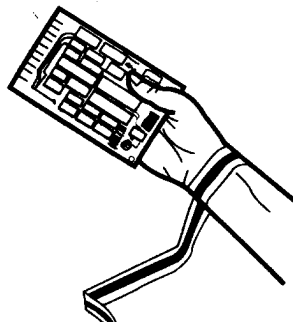

**Figure 11** Using the ESD Strap

## Overview of the Repairing the Pump

Figure 12 shows the main assemblies of the quaternary pump. The pump head and its parts do require normal maintenance (for example, seal exchange) and can be accessed from the front (simple repairs). Replacing internal parts will require to remove the quaternary pump from its stack and to open the top cover.

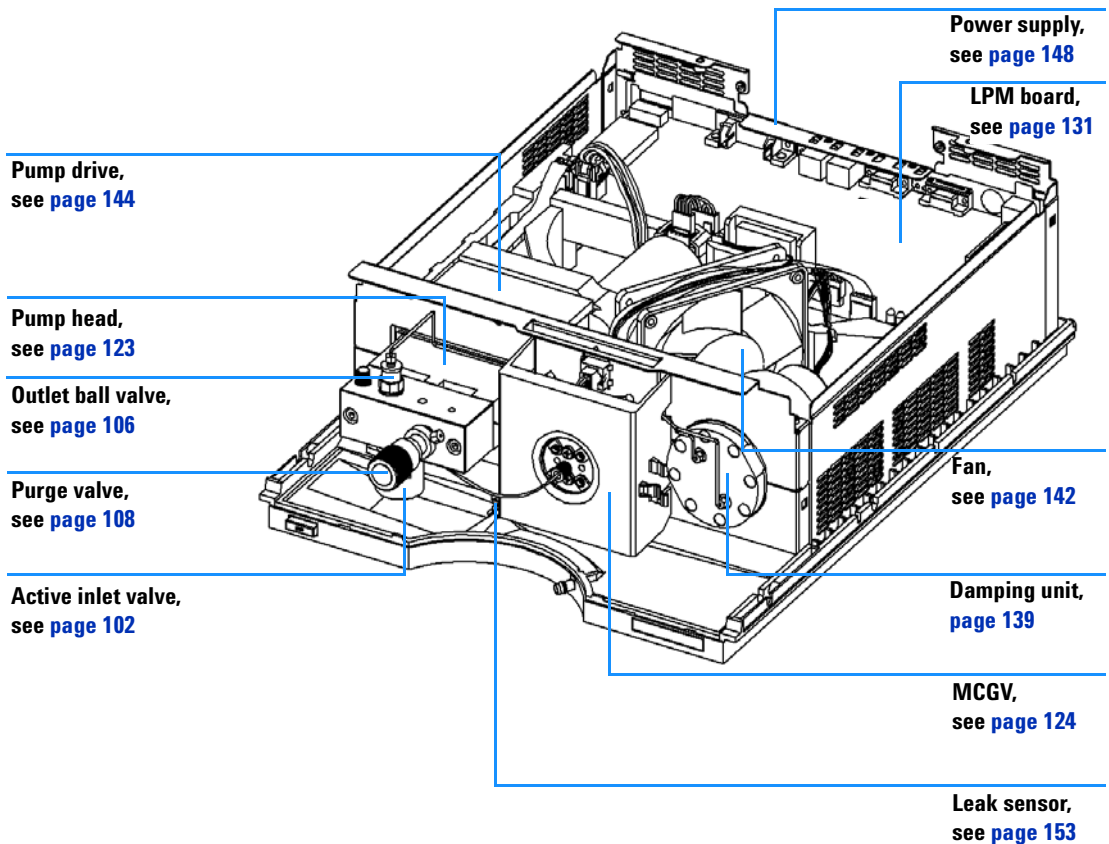

Figure 12 Overview of Repair Procedures

## Simple Repair Procedures

The procedures described in this section can be done with the quaternary pump in place in the system stack.

**Table 7** Simple Repair Procedures

Procedure	Typical Frequency	Notes
"Exchanging the Active Inlet Valve" on page 102	If internally leaking	Pressure ripple unstable, run leak test for verification
"Exchanging the Outlet Ball Valve" on page 106	If internally leaking	Pressure ripple unstable, run leak test for verification
"Exchanging the Purge Valve Frit or the Purge Valve" on page 108	If internally leaking	Solvent dripping out of waste outlet when valve closed
"Exchanging the Purge Valve Frit or the Purge Valve" on page 108	If the frit shows indication of contamination or blockage	A pressure drop of > 10 bar across the frit (5 ml/min H <sub>2</sub> O with purge open) indicates blockage
"Exchanging the Pump Seals and Seal Wear-in Procedure" on page 111	If pump performance indicates seal wear	Leaks at lower pump head side, unstable retention times, pressure ripple unstable — run leak test for verification
"Exchanging the Plungers" on page 114	If scratched	Seal life time shorter than normally expected — check plungers while changing the seals
"Installing the Continuous Seal Wash Option" on page 116	If seals show indication of leaks	Leaks at lower pump head side, loss of wash solvent

### Exchanging the Active Inlet Valve

<b>When required</b>	If internally leaking (backflow)
<b>Tools required</b>	Wrench 14 mm Pair of Tweezers
<b>Material</b>	Active inlet valve G1312-60010(complete assembly) Valve cartridge 5062-8562
<b>Preparations for this procedure</b>	Switch off isocratic pump at the main power switch

- 1 Remove the front cover.
- 2 Unplug the active inlet valve cable from the connector.
- 3 Disconnect the solvent inlet tube at the inlet valve (be aware that solvent may leak out of the tube due to hydrostatic flow).
- 4 Unscrew the adapter from the active inlet valve.
- 5 Using a 14 mm wrench loosen the active inlet valve and remove the valve from pump head.

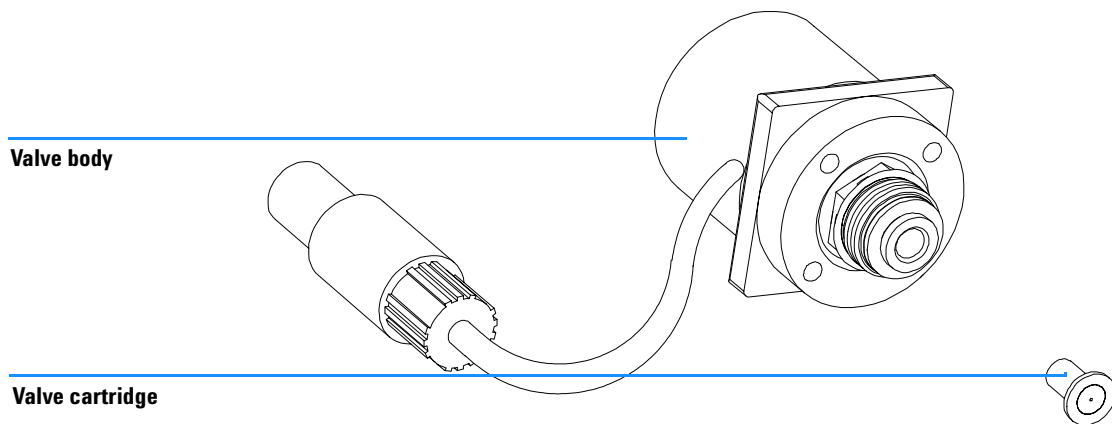

**Figure 13** Active Inlet Valve Assembly

- 6 Insert the new valve into the pump head. Using the 14 mm wrench turn the nut until it is hand tight.
- 7 Position the valve so that the solvent inlet tube connection points towards the front.

- 8 Using the 14 mm wrench tighten the nut by turning the valve in its final position (not more than a quarter turn).
- 9 Reconnect the adapter at the active inlet valve.
- 10 Reconnect the solvent inlet tube to the adapter. Reconnect the active inlet valve cable to the connector in the Z-panel.
- 11 Reinstall the front cover.

**NOTE**

After an exchange of the valve it may take several ml of pumping with the solvent used in the current application, before the flow stabilizes at a %-ripple as low as it used to be when the system was still working properly.

---

### Exchanging the Active Inlet Valve Cartridge

<b>When required</b>	If internally leaking (backflow)
<b>Tools required</b>	Wrench 14 mm Pair of Tweezers
<b>Material</b>	Active inlet valve G1312-60010 (complete assembly) Valve cartridge 5062-8562
<b>Preparations for this procedure</b>	Switch off isocratic pump at the main power switch

- 1 Remove the front cover
- 2 Unplug the active inlet valve cable from the connector.
- 3 Disconnect the solvent inlet tube at the inlet valve (be aware that solvent may leak out of the tube due to hydrostatic flow).
- 4 Unscrew the adapter from the active inlet valve.
- 5 Using a 14 mm wrench loosen the active inlet valve and remove the valve from pump head.
- 6 Using a pair of tweezers remove the valve cartridge from the actuator assembly.
- 7 Before inserting the new valve cartridge clean the area in the actuator assembly. Flush the cartridge area thoroughly with alcohol.
- 8 Insert a new valve cartridge into the actuator assembly (make sure the valve cartridge is fully inserted into the actuator assembly).
- 9 Insert the valve into the pump head. Using the 14 mm wrench turn the nut until it is hand tight.
- 10 Position the valve so that the solvent inlet tube connection points towards the front.
- 11 Using the 14 mm wrench tighten the nut by turning the valve in its final position (not more than a quarter turn).
- 12 Reconnect the adapter at the active inlet valve.
- 13 Reconnect the solvent inlet tube to the adapter. Reconnect the active inlet valve cable to the connector in the Z-panel.
- 14 Reinstall the front cover.



**NOTE**

After an exchange of the valve cartridge it may take several ml of pumping with the solvent used in the current application, before the flow stabilizes at a %-ripple as low as it used to be when the system was still working properly.

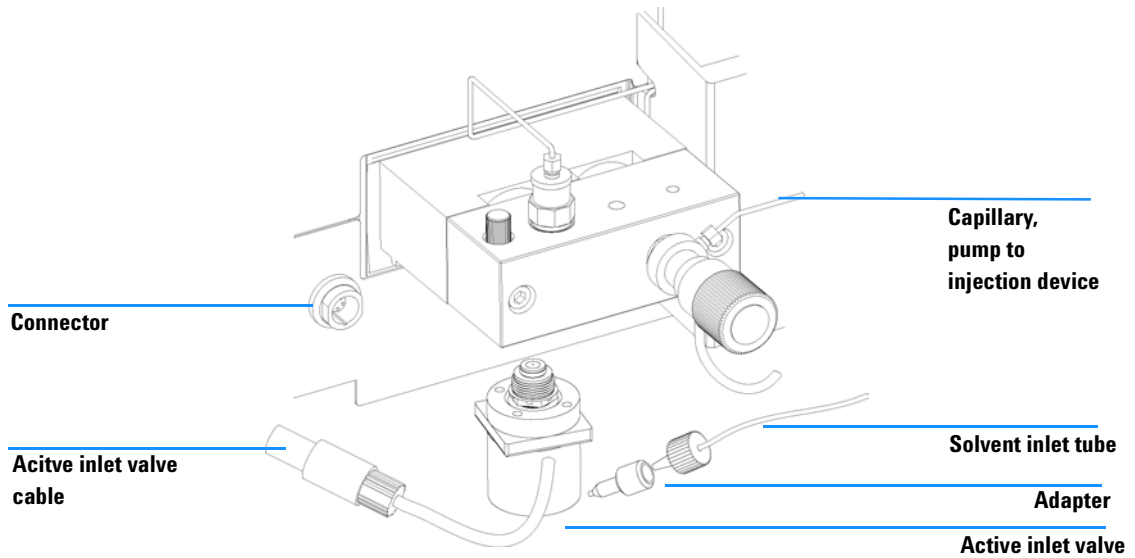

**Figure 14** Exchanging the Active Inlet Valve

### Exchanging the Outlet Ball Valve

<b>When required</b>	If internally leaking
<b>Tools required</b>	Wrench 1/4 inch Wrench 14 mm
<b>Parts required</b>	Outlet ball valve G1311-60012
<b>Preparations for this procedure</b>	Switch off isocratic pump at the main power switch Remove the front cover

#### NOTE

Before exchanging the outlet ball valve you can try to clean it in a sonic bath for 5 – 10 minutes. Place the valve in an upright position in a small beaker with alcohol.

- 1 Using a 1/4 inch wrench disconnect the valve capillary from the outlet ball valve.
- 2 Using the 14 mm wrench loosen the valve and remove it from the pump body.
- 3 Check that the new valve is assembled correctly and that the gold seal is present (if the gold seal is deformed, it should be replaced).

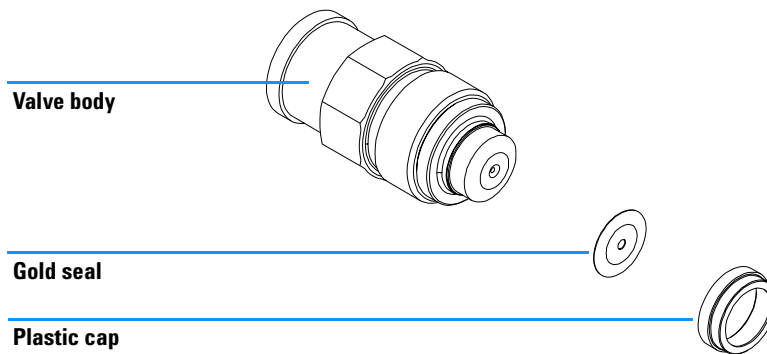

**Figure 15** Outlet Ball Valve Parts

- 4 Reinstall the outlet ball valve and tighten the valve.
- 5 Reconnect the valve capillary.

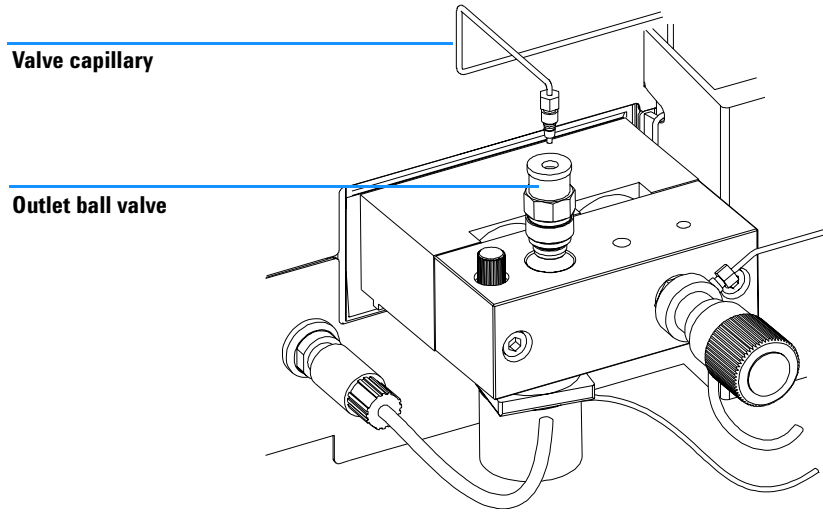
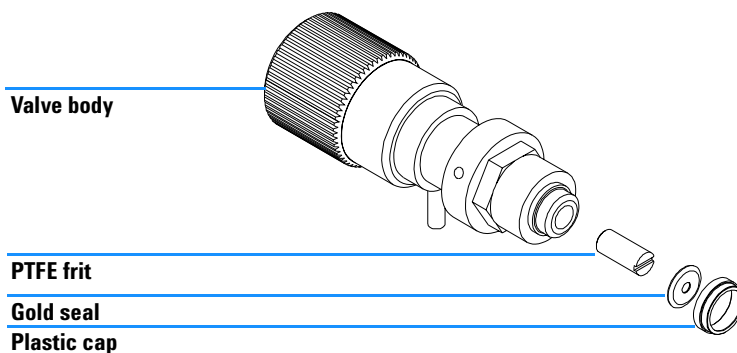

**Figure 16** Exchanging the Outlet Ball Valve

### Exchanging the Purge Valve Frit or the Purge Valve

<b>When required</b>	Frit – when plunger seals are exchanged or when contaminated or blocked (pressure drop of > 10 bar across the frit at a flow rate of 5 ml/min of H <sub>2</sub> O with purge valve opened)
<b>Tools required</b>	Purge valve – if internally leaking Wrench 1/4 inch Wrench 14 mm Pair of tweezers or toothpick
<b>Parts required</b>	PTFE frit (pack of 5) 01018-22707 Purge valve G1311-60009
<b>Preparations for this procedure</b>	Switch off isocratic pump at the main power switch Remove the front cover

- 1 Using a 1/4 inch wrench disconnect the pump outlet capillary at the purge valve.
- 2 Disconnect the waste tube. Beware of leaking solvents due to hydrostatic pressure.
- 3 Using the 14 mm wrench unscrew the purge valve and remove it.
- 4 Remove the plastic cap with the gold seal from the purge valve.
- 5 Using a pair of tweezers or a toothpick remove the frit.



**Figure 17** Purge Valve Parts

- 6 Place a new frit into the purge valve with the orientation of the frit as shown above.
- 7 Reinstall the cap with the gold seal.

**NOTE**

Before reinstallation always check the gold seal. A deformed seal should be exchanged.

8 Insert the purge valve into the pump head and locate the pump outlet capillary and the waste tube as shown in [Figure 18](#).

9 Tighten the purge valve and reconnect outlet capillary and waste tubing.

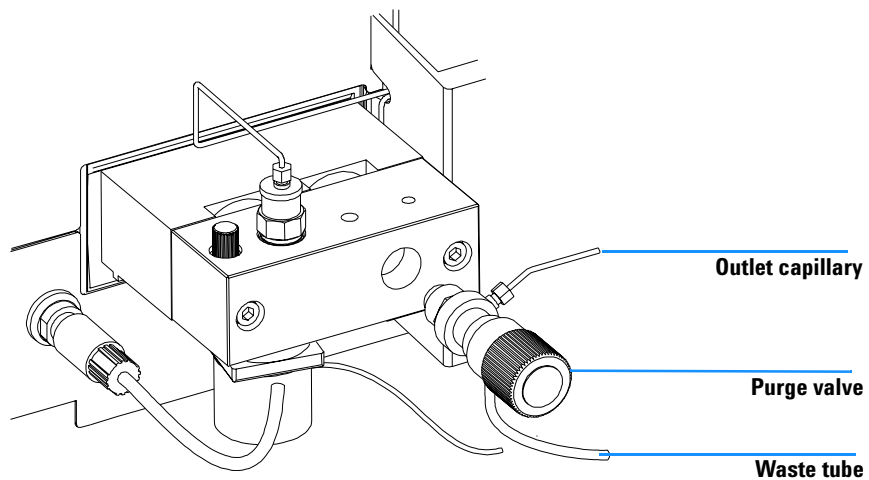

**Figure 18** Exchanging the Purge Valve

### Removing the Pump Head Assembly

**WARNING**

Never start the pump when the pump head is removed. This may damage the pump drive.

<b>When required</b>	Exchanging the seals Exchanging the plungers
<b>Tools required</b>	Exchanging seals of the seal wash option Wrench 1/4 inch 4-mm hexagonal key

**Preparations for this procedure** Switch off isocratic pump at the main power switch

- 1 Remove the front cover.
- 2 Disconnect the Active Inlet Valve cable.
- 3 Using a 1/4 inch wrench remove the outlet capillary.

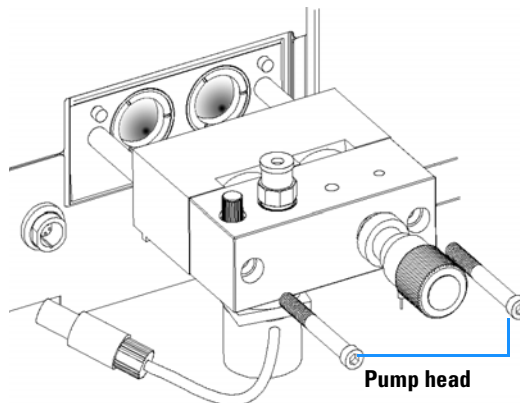

- 4 Disconnect the capillary from the Outlet Ball Valve.
- 5 Remove the waste tubing and disconnect the Active Inlet Valve tubing.
- 6 Remove the capillary at the bottom of the Pumphead.
- 7 Using a 4 mm hexagonal key, stepwise loosen the two Pumphead screws and remove the Pumphead from the Pump Drive.

## Exchanging the Pump Seals and Seal Wear-in Procedure

<b>When required</b>	Seal leaking, if indicated by the results of the leak test.
<b>Tools required</b>	Wrench 1/4 inch 4-mm hexagonal key
<b>Parts required</b>	Seals (pack of 2) 5063-6589 (standard) <i>or</i> 0905-1420 (for normal phase applications) For the seal wear-in procedure: Adapter AIV to inlet tube (0100-1847) Restriction capillary (5022-2159)
<b>Preparations for this procedure</b>	Switch off isocratic pump at the main power switch Remove the front cover <a href="#">"Removing the Pump Head Assembly"</a> on page 110

**1** Place the pump head on a flat surface. Loosen the lock screw (two revolutions) and while holding the lower half of the assembly carefully pull the pump head away from the plunger housing.

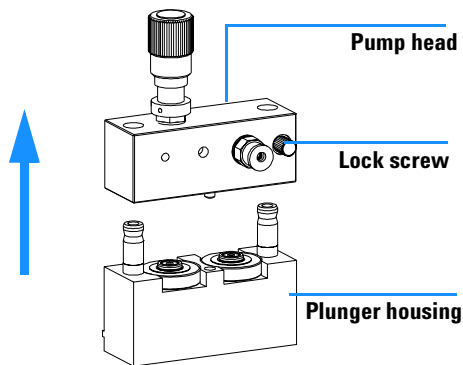

**2** Remove the support rings from the plunger housing and lift the housing away from the plungers.

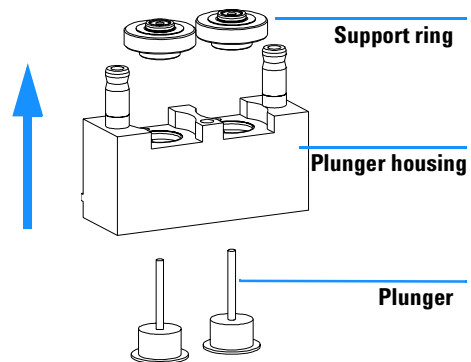

## 4 Repairing the Pump

3 Using one of the plungers carefully remove the seal from the pump head (be careful not to break the plunger). Remove wear retainers, if still present.

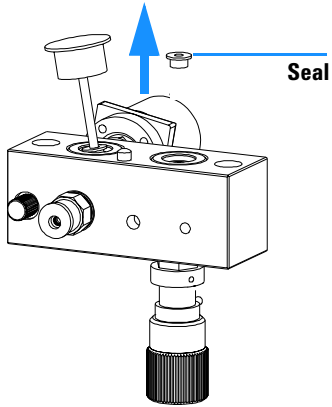

4 Insert new seals into the pump head.

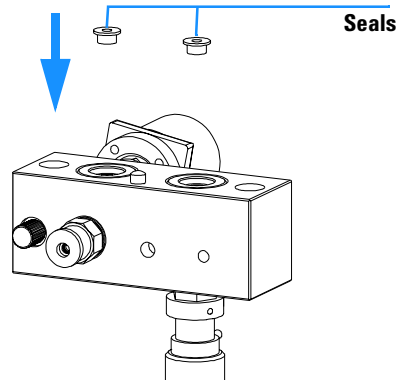

5 Reassemble the Pumphead assembly.

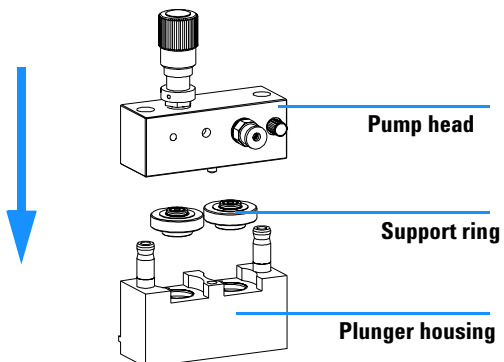



## Seal Wear-in Procedure

**NOTE**

This procedure is required for standard seals only (5063-6589), but it will definitely damage the normal phase application seals (0905-1420).

---

- 1** Place a bottle with 100 ml of Isopropanol in the solvent cabinet and place a tubing (including bottle head assembly) in the bottle.
- 2** Screw the adapter (0100-1847) to the AIV and connect the inlet tube from the bottle head directly to it.
- 3** Connect the restriction capillary (5022-2159) to the purge valve. Insert its other end into a waste container.
- 4** Open the purge valve and purge the system for 5 minutes with isopropanol at a flow rate of 2 ml/min.
- 5** Close the purge valve, set the flow to a rate adequate to achieve a pressure of 350 bar. Pump 15 minutes at this pressure to wear in the seals. The pressure can be monitored at your analog output signal, with the handheld controller, Chemstation or any other controlling device connected to your pump.
- 6** Turn OFF the pump, slowly open the purge valve to release the pressure from the system, disconnect the restriction capillary and reinstall the bottle with the solvent for your application.
- 7** Rinse your system with the solvent used for your next application.

## 4 Repairing the Pump

### Exchanging the Plungers

**When required**  
**Tools required**

When scratched  
Wrench 1/4 inch  
4-mm hexagonal key

**Parts required**  
**Preparations for this procedure**

Plunger 5063-6586  
Switch off isocratic pump at the main power switch  
Remove the front cover  
["Removing the Pump Head Assembly"](#) on page 110

1 Disassemble the Pumphead assembly.

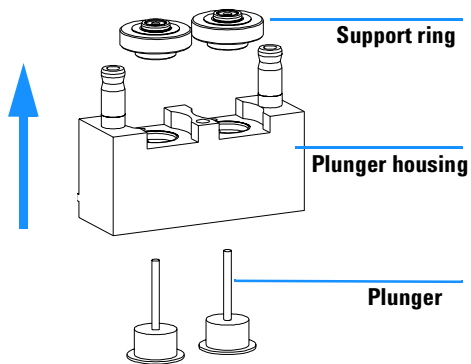

2 Check the plunger surface and remove any deposits or layers. Cleaning can be done with alcohol or tooth paste. Replace plunger if scratched.

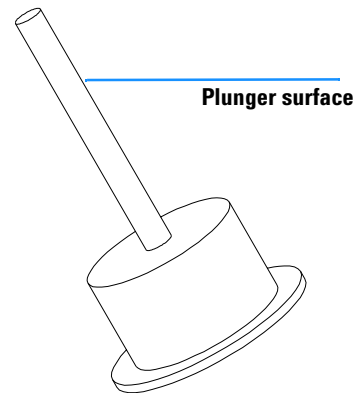

3 Reassemble the Pumthead assembly.

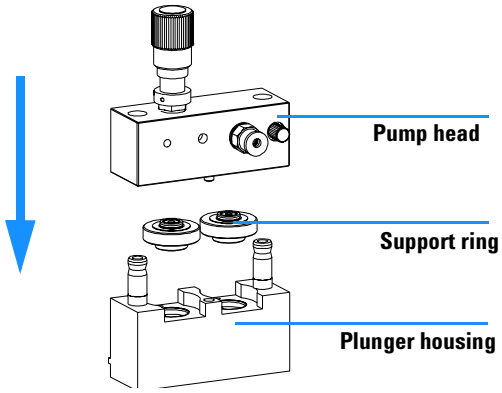

## 4 Repairing the Pump

### Installing the Continuous Seal Wash Option

<b>When required</b>	When installing seal wash option
<b>Tools required</b>	4-mm hexagonal key
<b>Parts required</b>	Seal wash kit 01018-68722
<b>Preparations for this procedure</b>	Switch off isocratic pump at the main power switch Remove the front cover

- 1** Disconnect all capillaries and tubes from the pump head and disconnect the active inlet valve cable.

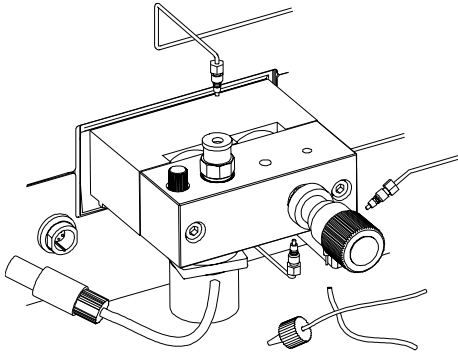

- 2** Using a 4-mm hexagonal key stepwise loosen and remove the two pump head screws and remove the pump head from the pump drive.

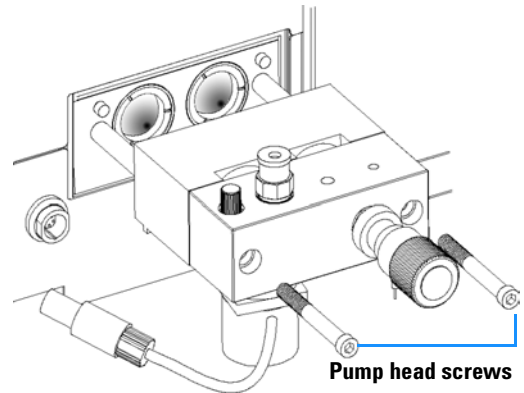

**3** Place the pump head on a flat surface. Loosen the lock screw (two revolutions) and while holding the lower half of the assembly carefully pull the pump head away from the plunger housing.

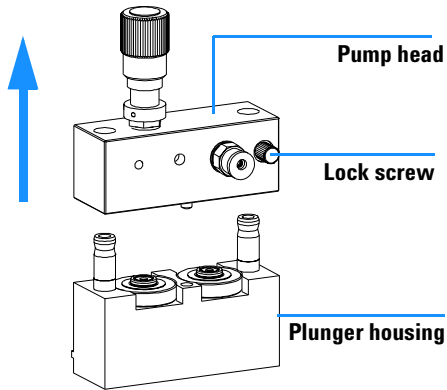

**4** Remove the support rings from the plunger housing and lift the housing away from the plungers.

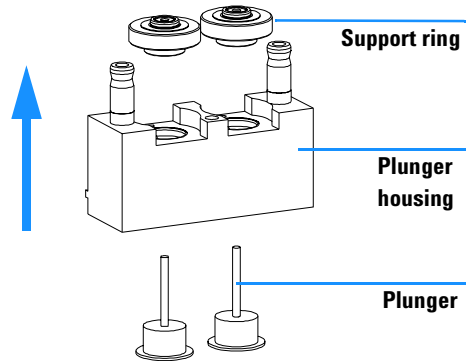

**5** Install the support ring assembly from the seal wash option kit into the plunger housing.

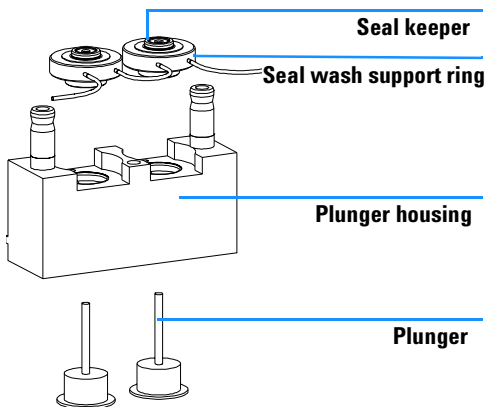

**6** Place the support rings on the plunger housing (plungers not installed) and snap the pump head and plunger housing together.

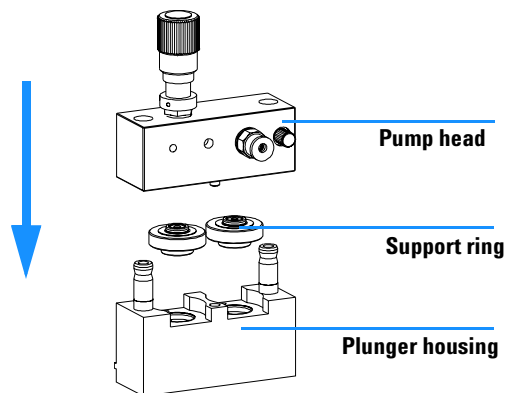

## 4 Repairing the Pump

7 Insert the plungers and carefully press them into the seal.

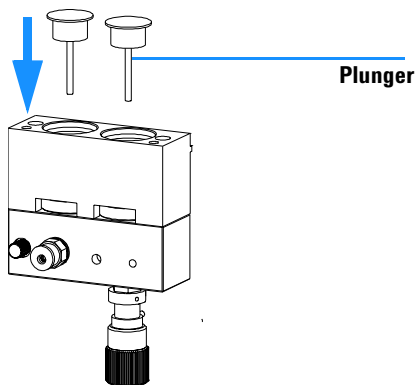

8 Tighten the lock screw.

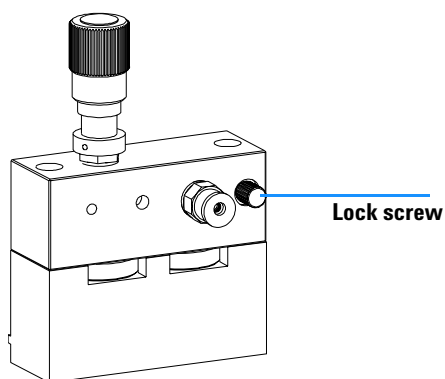

9 Slide the pump head assembly onto the metering drive. Apply a small amount of pump head grease to the pumphead screws and the balls of the spindle drive. Tighten the pumphead screws stepwise with increasing torque.

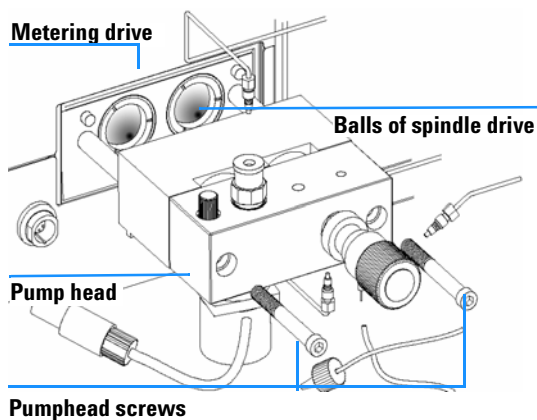

10 Reconnect all capillaries, tubes and the active inlet valve cable to its connector.

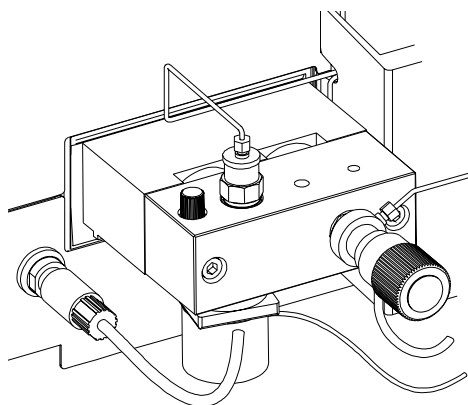

8 Route the wash inlet tube into a bottle filled with a mixture of distilled water and isopropanol (90/10) and place the bottle above the pump (hydrostatic pressure) in the solvent cabinet.

- 9 Route the outlet of the wash tube into a waste container.
- 10 The flow rate should be set to approximately 20 drops/minute. Use the velocity regulator attached to the wash tube to regulate the flow rate.

**NOTE**

The seals should never run dry. Running dry will significantly reduce the lifetime of the seals.

---

## 4 Repairing the Pump

### Exchanging the Wash Seals

**When required**

**Tools required**

**Parts required**

**Preparations for this procedure**

When maintaining seal wash option

4-mm hexagonal key

Wash seal 0905-1175

Gasket, seal wash (pack of 6) 5062-2484

Switch off isocratic pump at the main power switch

Remove the front cover

**1** Disconnect all capillaries and tubes from the pump head and disconnect the active inlet valve cable.

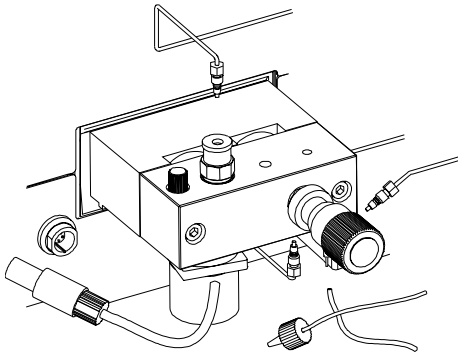

**2** Using a 4-mm hexagonal key stepwise loosen and remove the two pump head screws and remove the pump head from the pump drive.

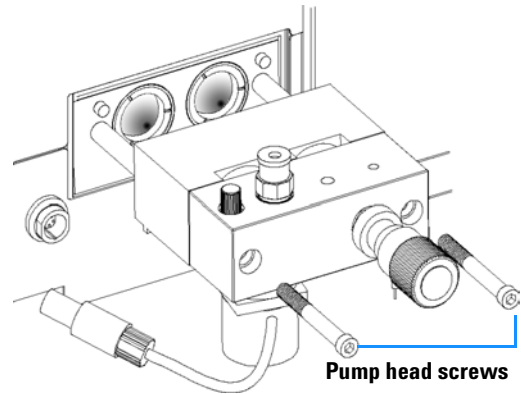



**3** Remove the seal keeper and the seal wash support rings from the plunger housing. Remove the seal keeper from the support ring assembly.

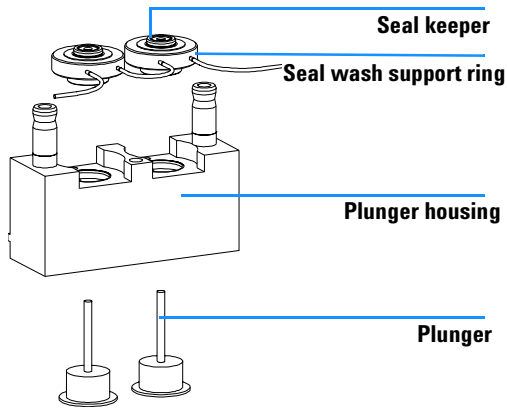

**4** Using the blade of a flat-blade screwdriver remove the seal wash gasket and the secondary seal from the support ring.

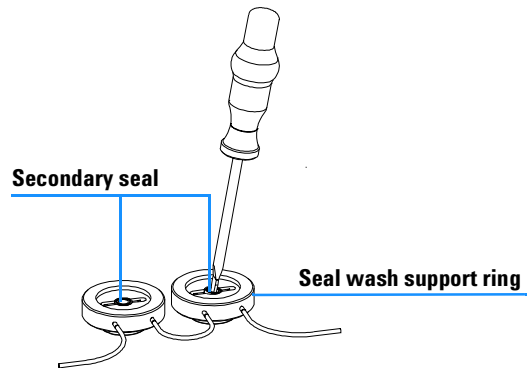

**5** Using the insert tool press the secondary seal (spring pointing upwards) into the recess of the support ring. Place a seal wash gasket in the recess of the support ring.

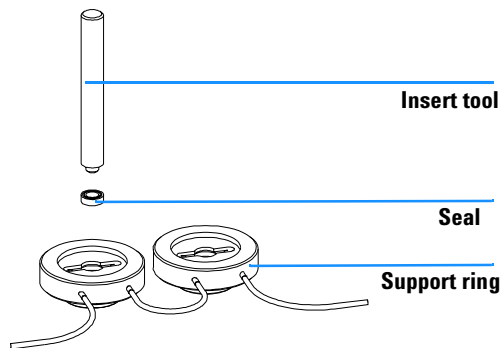

**6** Place the support rings on the plunger housing (plungers not installed) and snap the pump head and plunger housing together.

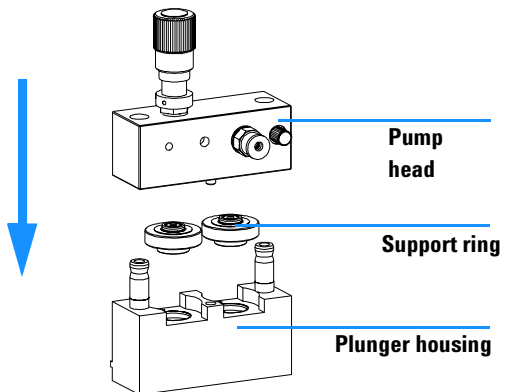

## 4 Repairing the Pump

**7** Insert the plungers and carefully press them into the seal.

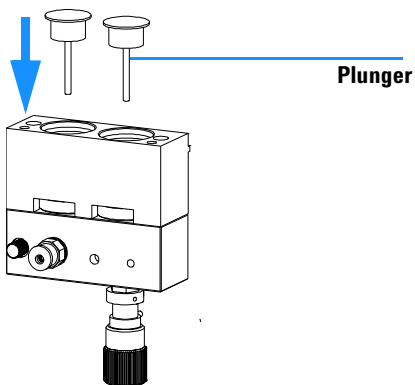

**8** Tighten the lock screw.

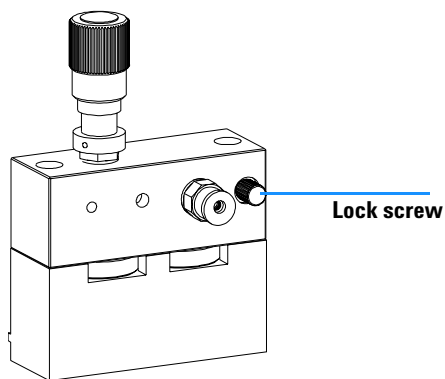

**9** Slide the pump head assembly onto the metering drive. Apply a small amount of pump head grease to the pumphead screws and the balls of the spindle drive. Tighten the pumphead screws stepwise with increasing torque.

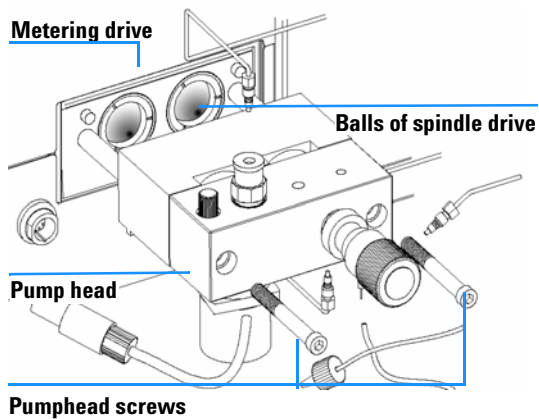

**10** Reconnect all capillaries, tubes and the active inlet valve cable to its connector.

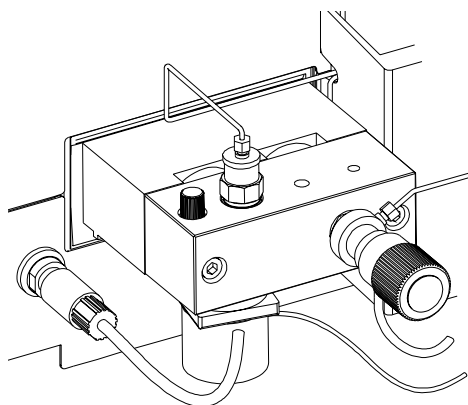

## Reinstalling the Pump Head Assembly

<b>When required</b>	When reassembling the pump
<b>Tools required</b>	4-mm hexagonal key
<b>Parts required</b>	Pump head grease (79846-65501)

- 1 Apply a small amount of grease on the back of the pistons.
- 2 Slide the Pumphead Assembly onto the Pumpdrive.
- 3 Using a 4 mm hexagonal key tighten the Pumphead screws stepwise with increasing torque.

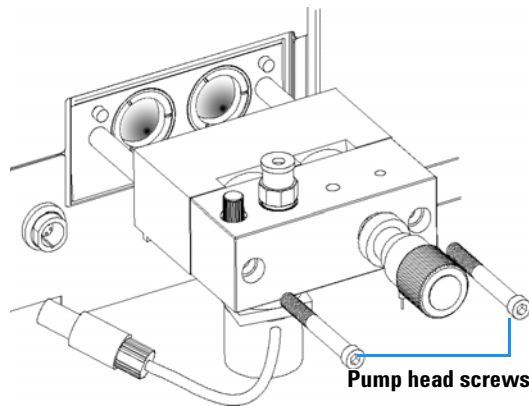

- 4 Reconnect the capillaries, tubing and the Active Inlet Valve cable to the connector.
- 5 Reinstall the front cover.

### Exchanging the Multi-Channel Gradient Valve (MCGV)

#### NOTE

The lifetime of the multi-channel gradient valve can be maintained by regularly flushing the valve, especially when using buffer solutions. If using buffer solutions, flush all channels of the valve with water to prevent precipitation of the buffer. Salt crystals can be forced into an unused channel and form plugs that may lead to leaks of that channel. Such leaks will interfere with the general performance of the valve.

When using buffer solutions and organic solvents in the Agilent 1100 Quaternary Pump it is recommended to connect the buffer solution to one of the bottom ports and the organic solvent to one of the upper gradient valve ports. It is best to have the organic channel directly above the salt solution channel (e.g., A - salt solution, B - organic solvent).

<b>Parts required</b>	MCGV (exchange assembly, G1311-69701)
<b>Tools required</b>	Pozidriv #1
<b>Preparations for this procedure</b>	Switch the quaternary pump off at the power switch.
	Remove the front cover to have access to the pump mechanics.

- 1 Disconnect the connecting tube, waste tube and the solvent tubes from the MCGV, unclip them from the tube clips and place them into the solvent cabinet to avoid flow by hydrostatic pressure.

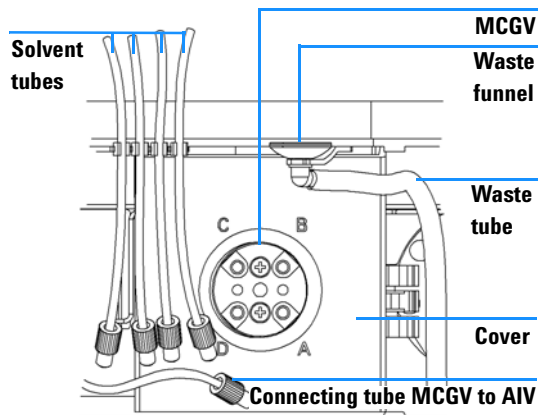

- 2 Press the lower sides of the cover to unclip it. Remove the cover.

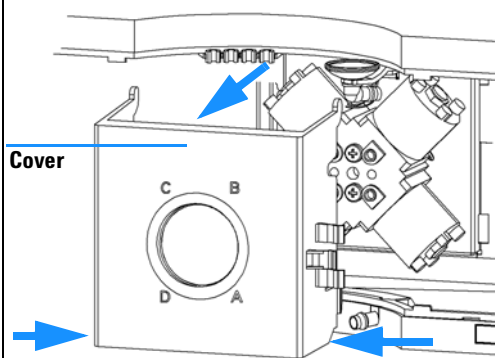

**3** Disconnect the MCGV cable, unscrew the two holding screws and remove the valve.

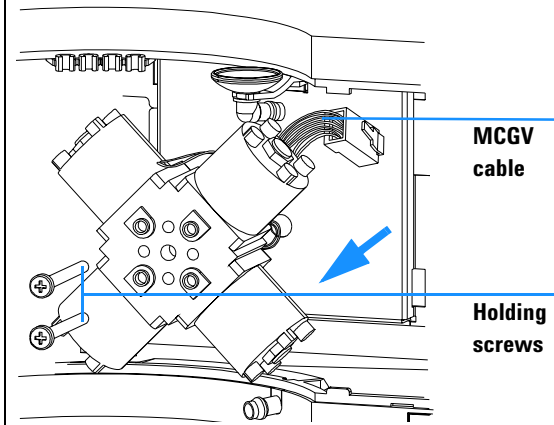

**4** Place the new MCGV into position. Make sure that the valve is positioned with the A-channel at the bottom-right position. Tighten the two holding screws and connect the cable to its connector.

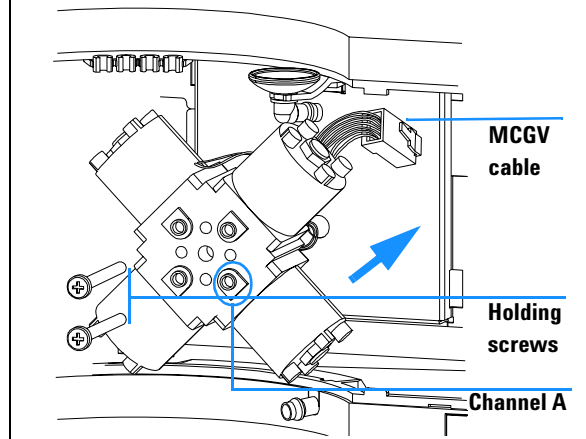

**5** Replace the MCGV cover. Reconnect the waste funnel with the waste tube holder in the top cover. Insert waste tube in the holder in the waste pan and clip tube to the MCGV cover.

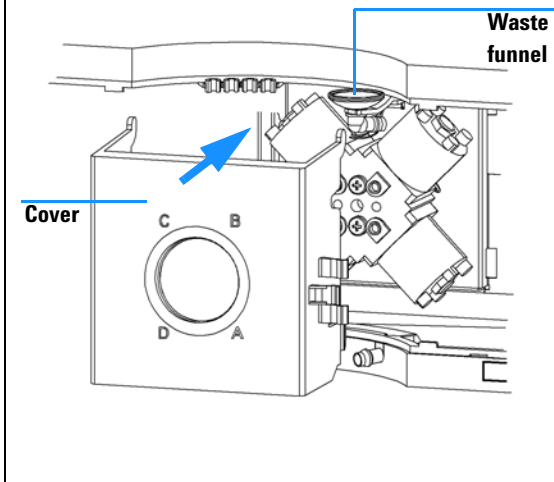

**6** Reconnect the tube from the active inlet valve to the middle position of the MCGV and then the solvent tubes at channel A to D of the MCGV. Make sure the orientation of the channels on the cover is labelled as shown below, otherwise re-label the cover.

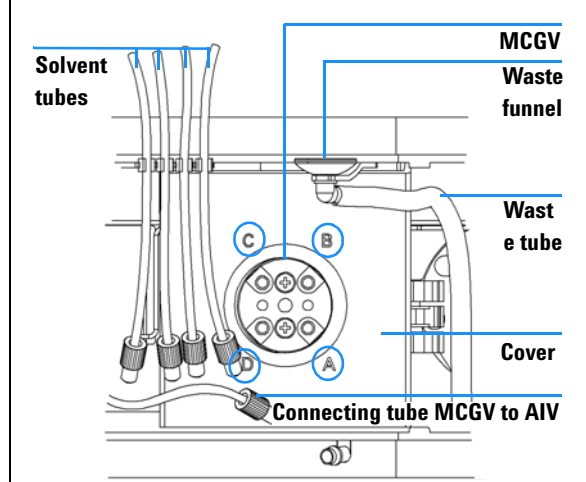

### Exchanging the Optional Interface Board

#### CAUTION

The interface board is sensitive to electrostatic discharge. Always use the ESD kit when handling electronic boards.

**When required** Board defective  
**Parts required** BCD (Interface) board (G1351-68701)

- 1 Switch off the quaternary pump at the main power switch, unplug the pump from line power.
- 2 Disconnect cables from the interfaceboard connectors.
- 3 Loosen the screws. Slide out the interface board from the quaternary pump.
- 4 Install the new interface board. Secure screws.
- 5 Reconnect the cables to the board connector.
- 6 Reconnect the pump to line power.

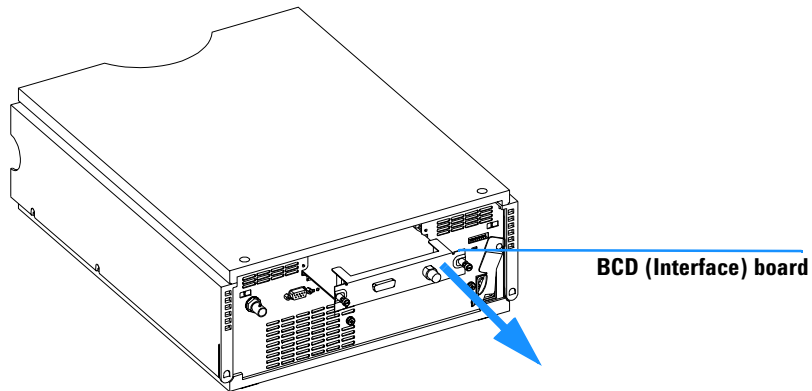

**Figure 19** Exchanging the Interface Board

## Exchanging Internal Parts

**WARNING**

The following procedures require opening the main cover of the quaternary pump. Always ensure the quaternary pump is disconnected from line power when the main cover is removed. The security lever at the power input socket prevents that the pump cover is taken off when line power is still connected.

---

**WARNING**

To disconnect the quaternary pump from line, unplug the power cord. The power supply still uses some power, even if the switch on the front panel is turned off.

---

**WARNING**

When opening capillary or tube fittings solvents may leak out. Please observe appropriate safety procedures (for example, goggles, safety gloves and protective clothing) as described in the material handling and safety data sheet supplied by the solvent vendor, especially when toxic or hazardous solvents are used.

---

**NOTE**

The electronics of the quaternary pump will not allow operation when the top cover and the top foam are removed. A safety light switch on the main board will inhibit the operation of the quaternary pump. Always operate the quaternary pump with the top foam and top covers in place.

---

**CAUTION**

Internal components may be sensitive to electrostatic discharge (ESD). Always use an ESD kit when handling internal parts.

---

The procedures in this section describe how to exchange internal parts. You must remove the quaternary pump from the stack in order to open the main cover.

## 4 Repairing the Pump

### Removing the Top Cover and Foam

**Tools required**

Screwdriver Pozidriv #1

**Preparations for this procedure**

Switch off quaternary pump at the main power switch.

Disconnect the solvent inlet and outlet tubes from the pump.

Beware of leaking solvents due to hydrostatic flow.

Remove the solvent cabinet from the quaternary pump.

Remove leak funnel with the waste tube from the top cover of the quaternary pump.

**1** Remove the front cover by pressing the both clip fasteners on both sides of the cover.

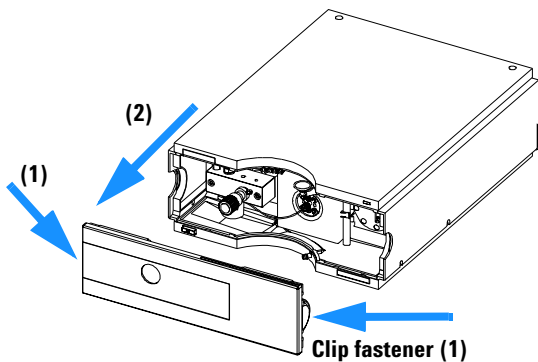

**2** Unplug the power cord and move the lever towards the power socket.

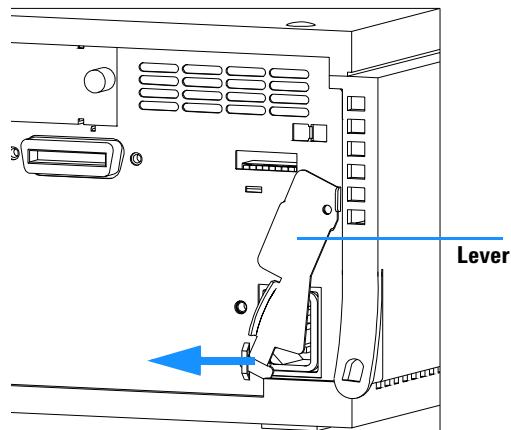



**3** Lift the clips on both sides of the top cover (1). Remove the top cover (2).

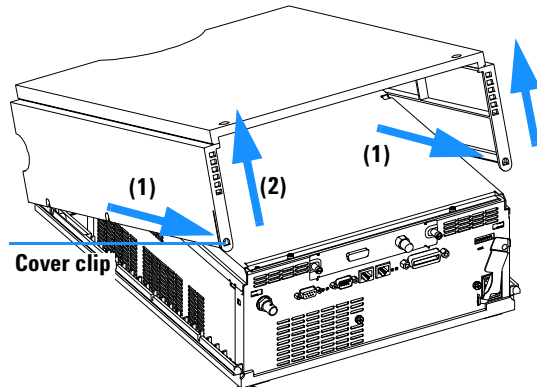

**4** Unscrew the screws on the top plate and remove the plate by lifting its back first and then sliding to the front.

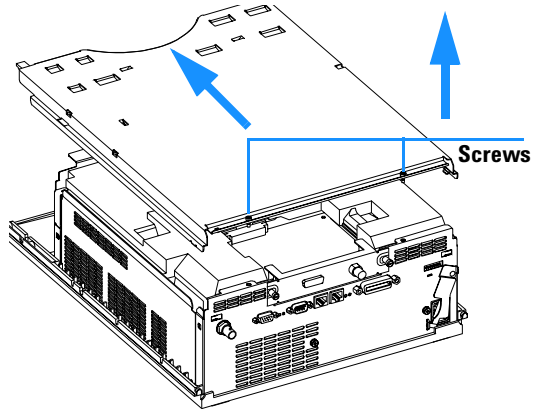

**5** If an optional interface board is installed, remove it from the pump slot.

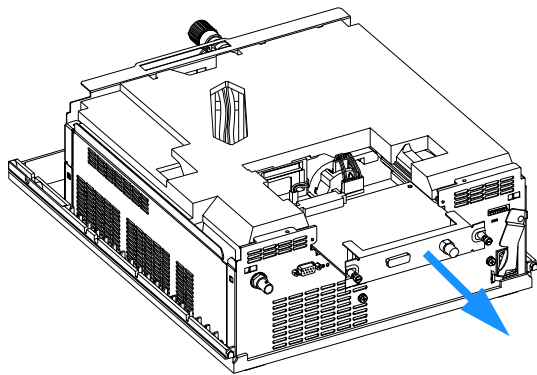

**6** Remove the top foam.

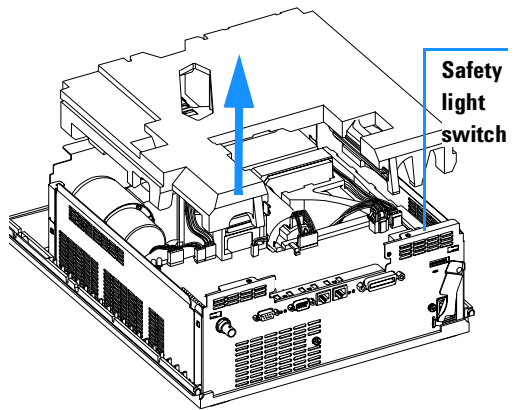

## 4 Repairing the Pump

**Do not connect a power plug to the quaternary pump after removing the top covers.**

**A safety light switch on the main board will prevent operation when the covers are removed.**

**The next figure shows the position of the safety light switch on the board.**

**7 Note the position of the safety light switch on the main board.**

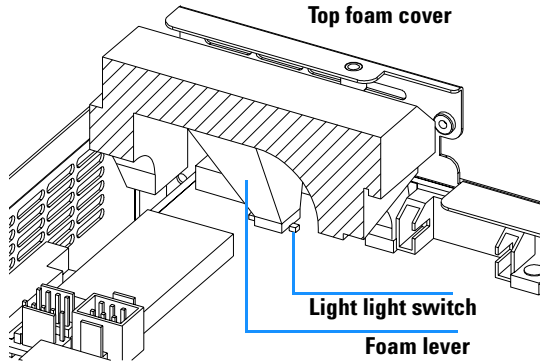

## Exchanging the Low Pressure Pump Main Board (LPM Board)

<b>When required</b>	Board defective
<b>Tools required</b>	Wrench 14 mm Wrench 7 mm Wrench 5 mm
<b>Parts required</b>	LPM Board, G1311-66520, exchange part number G1311-69520

- 1 Turn off the pump, disconnect all cables and remove the pump from the stack.
- 2 Remove the top cover and foam (see "[Removing the Top Cover and Foam](#)" on page 128).
- 3 Disconnect all connectors from the main board.

**NOTE**

When removing connectors, counterhold on connector J3 with one hand.

---

## 4 Repairing the Pump

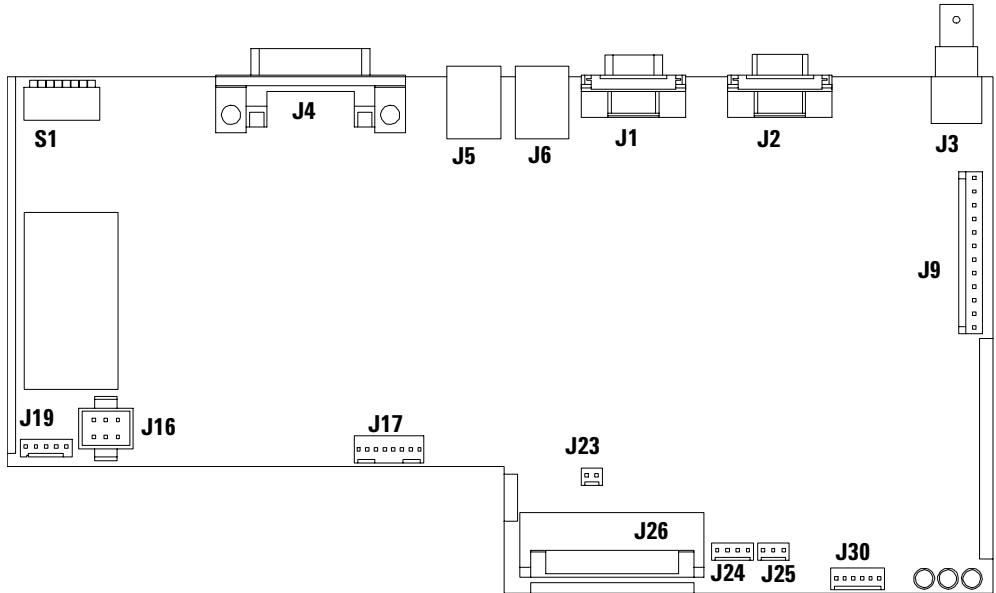

**Figure 20** LPM Board Connectors

**Table 8** Identifying Connectors on the LPM Board

Connector	Description	Connector	Description
J1	RS232	J17	Encoder
J2	Remote	J19	AIV
J3	Analog Pressure signal	J23	Leak sensor
J4	GPIB	J24	Damper
J5/6	CAN connector	J25	Fan
J9	Power supply	J26	Interface board
J16	Motor	J30	MCGV

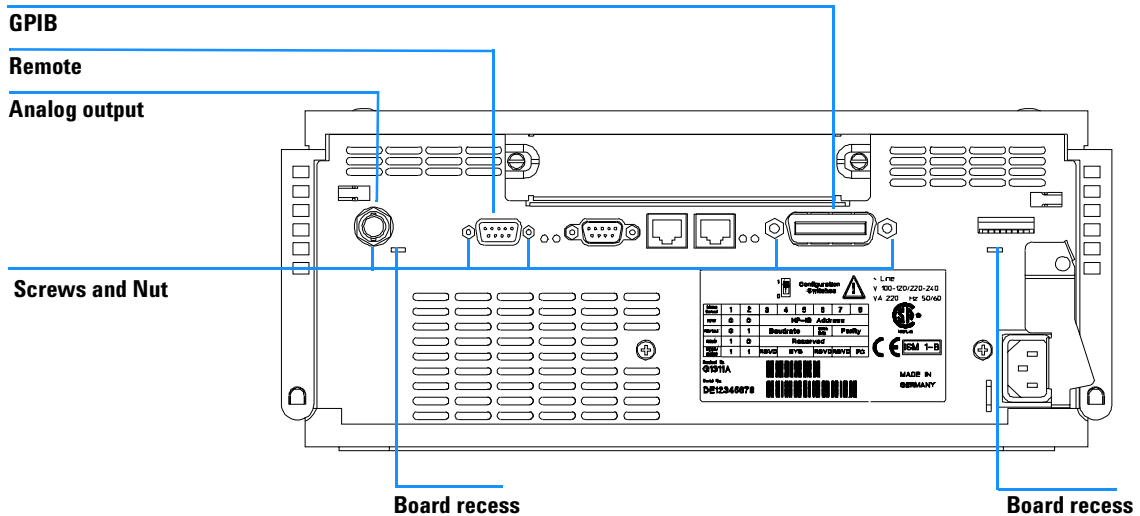

**Figure 21** Removing the Screws at the Back Plane.

- 4 Remove the connector screws from the GPIB, Remote and the analog pressure output connector.
- 5 Remove the board. Place the board on the ESD kit.

**WARNING**

The RFI spring plate sitting on the board connectors is very sharp! Be careful, not to cut yourself, when removing it from the old board and sliding it onto the new board.

- 6 In most cases the RFI spring plate (Radio Frequency Interference spring plate, prevents radio emissions from the instrument to ambient) remains on the interface connectors of the board. Carefully remove the spring plate from the old board and slide it onto the new board before installing the board in the pump (the RFI spring plate is NOT part of an exchange board).

**NOTE**

If you have to exchange other parts also, continue with that work, first.

## 4 Repairing the Pump

- 7 On the new board check the switch setting of address switch S1, see "[Setting the 8-bit Configuration Switch](#)" on page 230.

### NOTE

An incorrect switch setting (e.g., TEST/BOOT) may cause the pump to turn into a basic mode (yellow or red flashing status light). In such a case turn off the pump, re-set the address switches, and turn on the pump again.

---

- 8 Install the new board and reconnect the connectors. Make sure that the board is fitted correctly in the board recess holes at the rear panel.
- 9 Refit the connector screws, and reconnect all connectors. Ensure the connectors are seated securely.
- 10 Replace foam and top covers, see "[Replacing the Top Cover and Foam](#)" on page 157.
- 11 Reinstall the pump in the stack. Reconnect all cables. Turn on the quaternary pump. If pump status indicator turns red continue with the section "[Entering the Type Command](#)" on page 134, otherwise continue with "[Entering the Serial Number using the Control Module](#)" on page 136.

### Entering the Type Command

### NOTE

The main board is physically identical for the isocratic and the quaternary pump. After the installation of a new mainboard the *TYPE* (isocratic or quaternary) of the module is normally automatically detected. The specific *TYPE* tells the pump how to configure itself during turn on. In some cases, especially when a defective mainboard is replaced with an older version of mainboard, the automatic *TYPE* detection does not work. When the *TYPE* of the exchange main board does not match the pump, a pump configuration error will occur during pump turn on. This will cause the pump status indicator to be red. In this case the *TYPE* of the module has to be entered using the procedure described in the following sections.

---

You must change the *TYPE* of the replacement main board to agree with the quaternary pump (G1311A). The *TYPE* can be entered using either the control module or the ChemStation, see "[Entering the Type Command using the Control Module](#)" on page 135 or "[Entering the Type Command using the ChemStation](#)" on page 135.

### Entering the Type Command using the Control Module

- 1 Connect the control module to the pump.
- 2 From *Views* (press F5) select the *System* screen, then press *Tests* (F3).
- 3 Using the up/down arrows, make sure that the quaternary pump is highlighted and press *Enter*. The Tests screen for the quaternary pump should now be displayed.
- 4 While in the *Tests* screen, press m.m (m dot m). From the box now displayed, select the *Command* line, and press *Enter*.
- 5 Into the box labeled *Instr*, enter the command TYPE G1311A.
- 6 Letters and numbers are created using the up and down arrows. There must be a blank space between the word TYPE and the letter G.

#### NOTE

It is important to enter the TYPE command correctly. An incorrect type command may cause the module to turn on in it's resident mode. In such a case, re-enter the TYPE command correctly.

- 7 When the command is entered, press *Enter* to highlight the complete command.
- 8 Press the *Execute* (F8) key. Below the box, a reply line should then say: Reply RA 0000 TYPE "G1311A" .
- 9 Turn off the module, then turn it on again. Turn on should be normal. In the *Records* screen, the product# column should indicate the quaternary pump. If a chemstation is also connected, re-boot it now.

### Entering the Type Command using the ChemStation

The TYPE is entered by typing a specific command into the command line at the bottom of the main user interface screen.

- 1 To enter the TYPE for a specific module, type the following command into the command line:

```
print sendmodule$(lpmp, "TYPE G1311A")
```

### NOTE

It is important to enter the TYPE command correctly. An incorrect type command may cause the module to turn on in it's resident mode. In such a case, re-enter the TYPE command correctly.

---

- 2 The reply line will respond with RA 0000 Type "G1311A".
- 3 Turn the quaternary pump off, then on again. Then, re-boot the ChemStation. Boot up and subsequent control of the system should be normal.
- 4 The TYPE of a module can also be identified by typing the following command into the command line:

```
print sendmodule$ (lpmp, "TYPE?")  
The reply line will give the module TYPE.
```

### Entering the Serial Number using the Control Module

- 1 Connect the control module to the quaternary pump. Turn on the pump.
- 2 In the control module, press *Views (F5)* and select the *system* screen, then press *Records (F4)*. Using the up/down arrows, make sure that the quaternary pump is highlighted.
- 3 Press *FW Update (F5)*. Now, press the *m* key. This will display a box which says *Update Enter Serial#*.
- 4 Press *Enter*. This will display the box labeled *Serial#*.
- 5 Letters and numbers are created using the up and down arrows. Into the box labeled *Serial#*, enter the 10-character serial number for the quaternary pump. When the 10-character serial number is entered, press *Enter* to highlight the complete serial number. Then, press *Done (F6)*.

### NOTE

For firmware revisions below A02.00 it is very important never to press *Done* if the *Serial#* box is blank. In this case, the module can no longer be recognized by either the control module or the ChemStation. The main board must then be replaced.

---

- 6 Turn the quaternary pump off, then on again. The *Records* screen should display the correct serial number.
- 7 If a ChemStation is also connected, re-boot the ChemStation now as well.



### Entering the Serial Number using the ChemStation

Module serial numbers are entered by typing specific commands into the command line at the bottom of the main user interface screen.

- 1 To enter a module serial number, type the following command into the command line:

```
print sendmodule$(lpmp, "ser YYYYYYYYYY")
```

Where: YYYYYYYYYY is the 10-character serial number of the quaternary pump

#### NOTE

The first two characters are letters, which should be capitalized.

The reply line will respond with RA 0000 SER followed by the module serial number you just entered.

- 2 Turn off the quaternary pump, then on again. Then, re-boot the ChemStation. If the serial number you have just entered is different than the original module serial number, you will be given the opportunity to edit the configure 1100 access screen during the re-boot of the ChemStation.
- 3 After boot-up, the serial number you have just entered can be seen under the *Instrument menu* of the main user interface screen. The serial number of the quaternary pump can also be seen by typing the following command into the command line:

```
print sendmodule$(lpmp, "ser?")
```

The reply line will give the serial number of the quaternary pump.

### Replacing the Quaternary Pump's Firmware

The installation of new firmware is required

- if a new version solves problems of the currently installed version.
- if the version of firmware on the new main board (LPM) after an exchange of the board is older than the one previously installed.

## 4 Repairing the Pump

To upgrade the quaternary pump's firmware follow the procedures and instructions given on the internet @:

<http://www.agilent.com/chem>

to download and install always the newest available version of firmware on your system or call your local service provider for assistance.

## Exchanging the Damper

**When required**

No pressure output or when leaking

**Tools required**

Screwdriver Pozidriv #1

**Parts required**

Wrench 1/4 inch

Damper 79835-60005

**1** Switch off the pump at the main power switch, remove all cables and tubings, remove the pump from the stack. Remove the front cover, top cover and top foam section (see ["Removing the Top Cover and Foam"](#) on page 128).

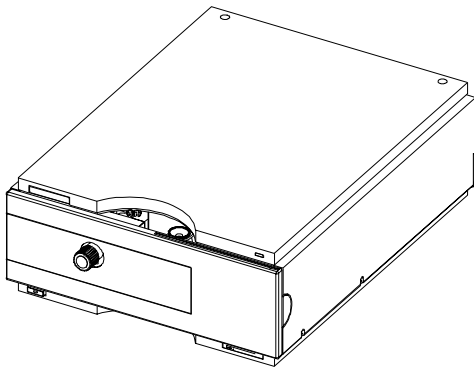

**2** Remove the gradient valve (MCGV) cover (see ["Exchanging the Multi-Channel Gradient Valve \(MCGV\)"](#) on page 124).

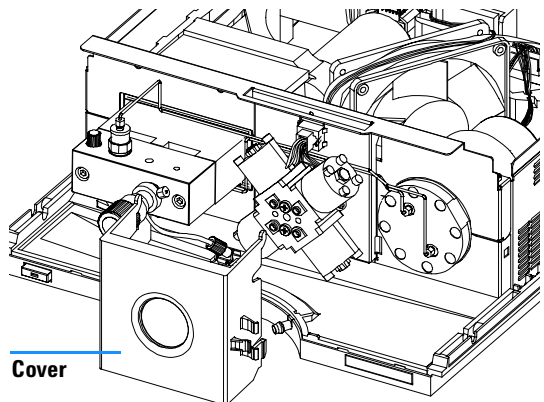

## 4 Repairing the Pump

**3** Disconnect the two damper capillaries.

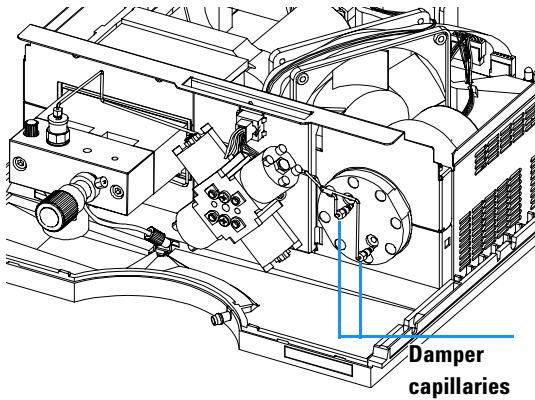

**4** Loosen the screws of the Z-panel and take it out of the instrument.

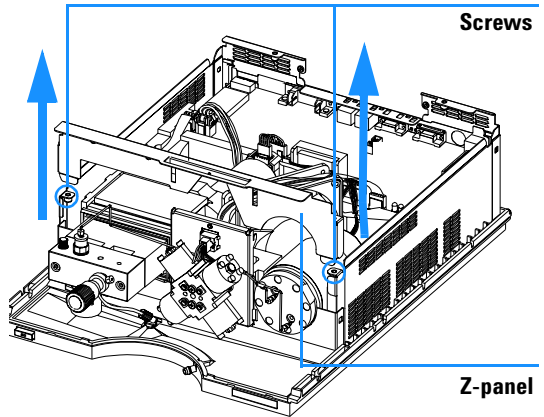

**5** Disconnect the damper connector at the main board (J24). Lift the damper out of its position.

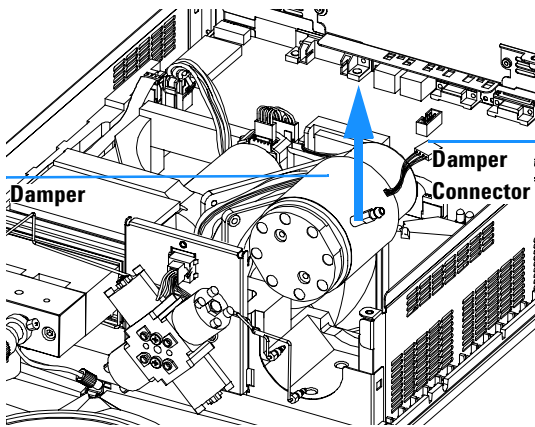

**6** Place the new damper into the recess and connect to the main board (J24).

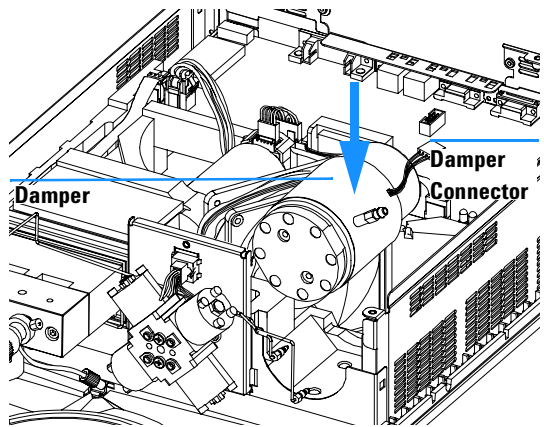

**7** Place the Z-panel into position and fix it with the two screws.

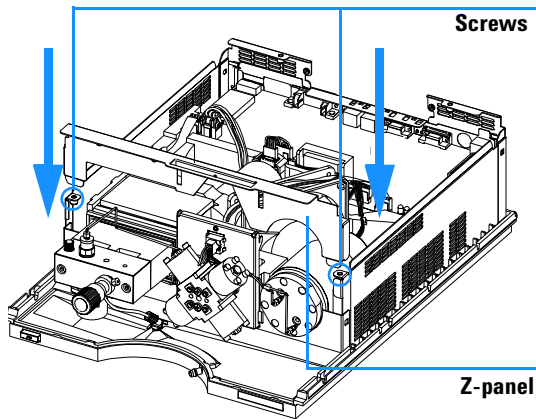

**8** Reconnect the two damper capillaries.

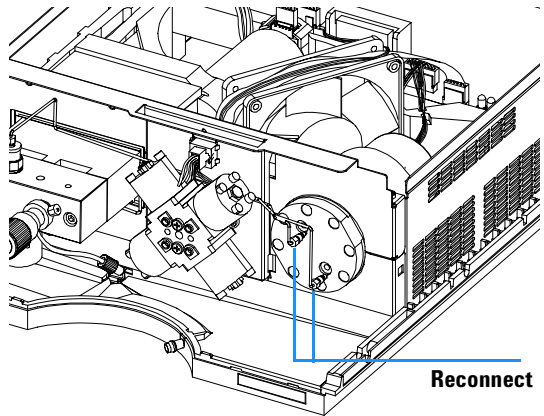

**9** Clip the valve cover into its position and connect the tubings back to the valve ports.

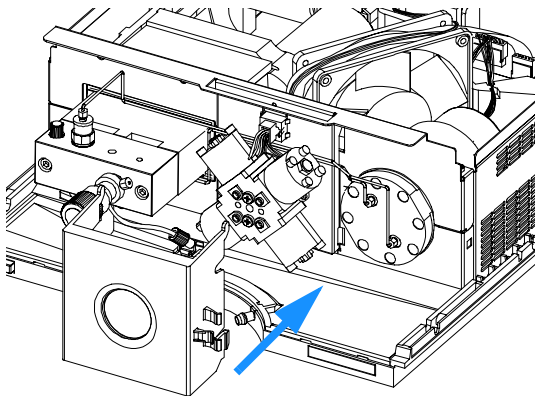

**10** Replace the top foam section, optional interface board (if installed), metal cover and top cover (see "Replacing the Top Cover and Foam" on page 157). Replace the pump on stack, reconnect all tubings and cables.

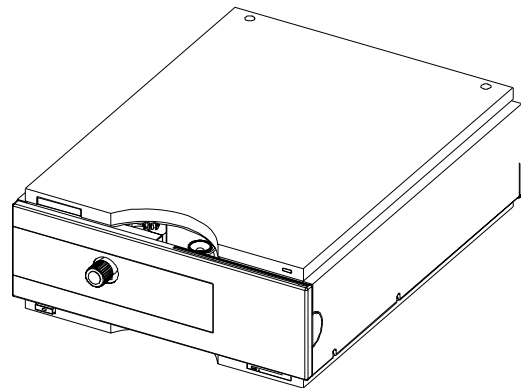

### Exchanging the Fan

<b>When required</b>	Fan not running
<b>Tools required</b>	Screwdriver Pozidriv #1
<b>Parts required</b>	Fan, part number 3160-1016

- 1 Switch off the pump at the main power switch, remove all cables and tubings, remove the pump from the stack.
- 2 Remove the front cover, top covers and foam (see "[Removing the Top Cover and Foam](#)" on page 128)
- 3 Disconnect the fan connector at the processor board (J25).
- 4 Slide the cables on the fan housing aside and lift the fan out of the quaternary pump.
- 5 Slide the new fan into its position and connect to J25 on the main board.

#### CAUTION

Make sure that air flow is directed as indicated (same direction for arrow on the fan and arrow on the bottom foam).

- 
- 6 Reinstall foam, top covers and front cover, see "[Replacing the Top Cover and Foam](#)" on page 157.

7 Replace the pump on stack, reconnect all tubings and cables.

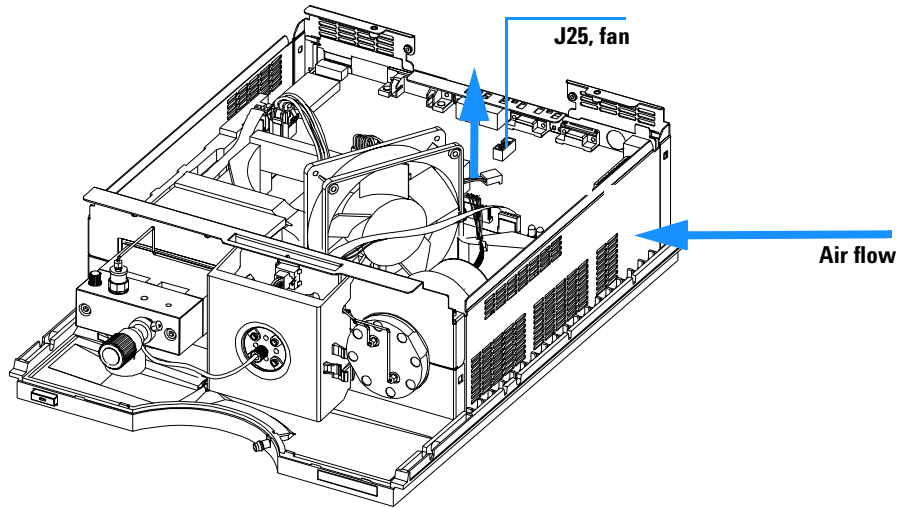

**Figure 22** Exchanging the Fan

## Exchanging the Pump Drive

**WARNING**

Never start the pump when the pump head is removed. This may damage the pump drive.

**When required  
Tools required**

Error message: Motor Drive Power  
Screwdriver Pozidriv #1  
Wrench 1/4 inch

**Parts required  
Preparations for this  
procedure**

4-mm hexagonal key  
Pump drive G1311-60001, exchange part number G1311-69001  
Switch off the pump at the main power switch, remove all cables and tubings, remove the pump from the stack. Remove the front cover, top cover and top foam section (see "Removing the Top Cover and Foam" on page 128

1 Remove the tubings from the gradient valve (MCGV) and remove the valve cover (see "Exchanging the Multi-Channel Gradient Valve (MCGV)" on page 124).

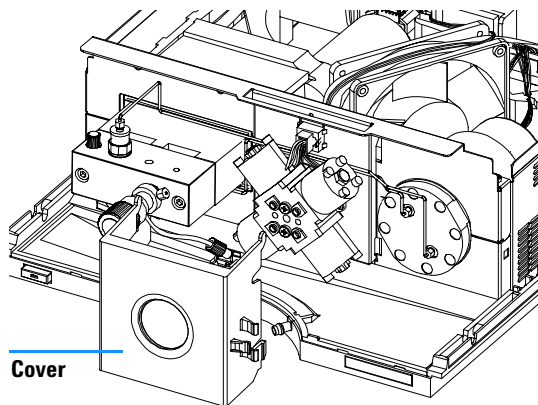

2 Disconnect all capillaries and tubes from the pump head and disconnect the active inlet valve connector.

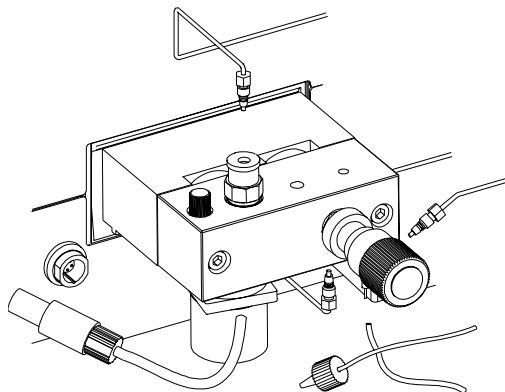



**3** Remove the tubings from the gradient valve (MCGV) and remove the valve cover (see "Exchanging the Multi-Channel Gradient Valve (MCGV)" on page 124).

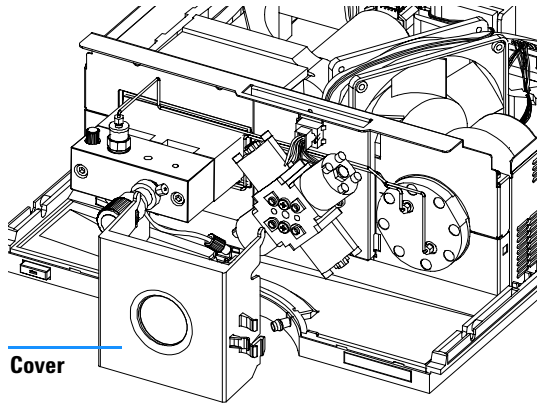

**4** Disconnect all capillaries and tubes from the pump head and disconnect the active inlet valve connector.

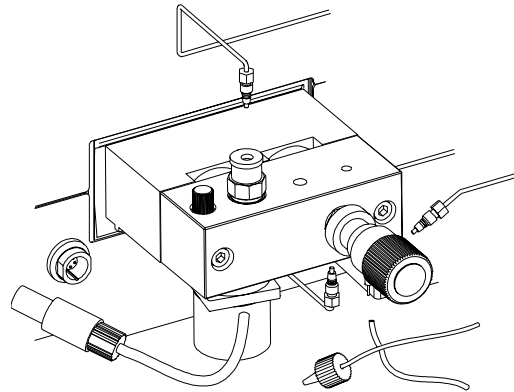

**5** Loosen the screws of the Z-panel and take it out of the instrument.

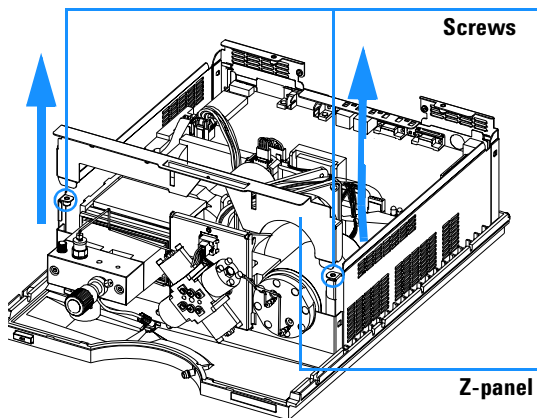

**6** Using a 4-mm hexagonal key stepwise loosen and remove the two pump head screws and remove the pump head from the pump drive.

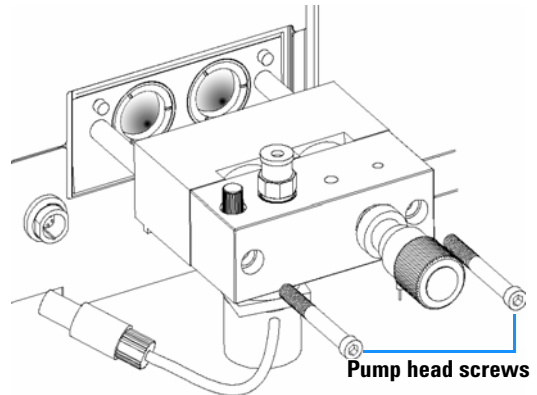

## 4 Repairing the Pump

**7** Disconnect the pump drive cables from the main board (J16, J17) and lift the drive out of the foam.

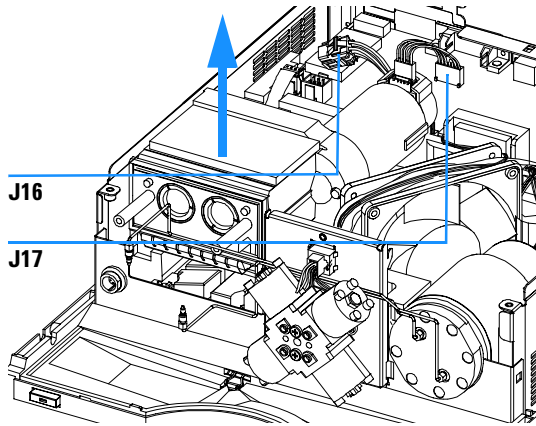

**8** Place the new pump drive into the recess in the foam part and connect the cables to the connectors on the main board (J16 Motor, J17 Encoder).

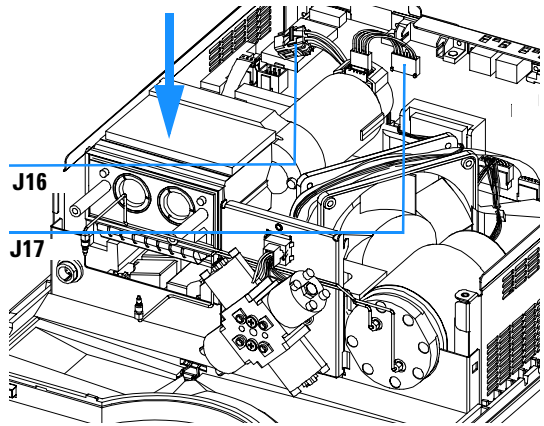

**9** Reinstall the pump head and fix with the two screws.

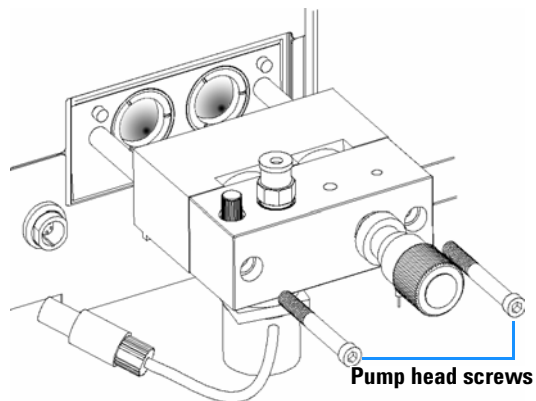

**10** Replace the Z-panel and fix it with the two screws.

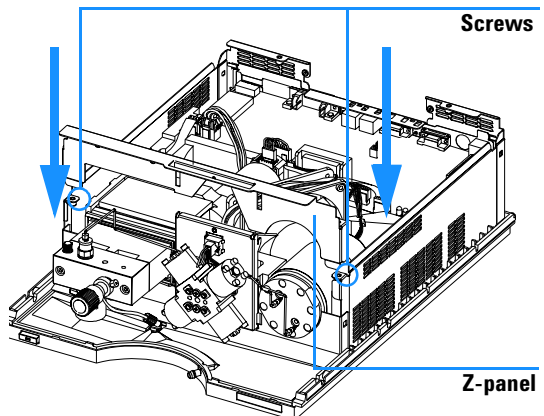

**11** Replace the MCGV cover and connect the connection tube to the middle position of the MCGV (see "Exchanging the Multi-Channel Gradient Valve (MCGV)" on page 124).

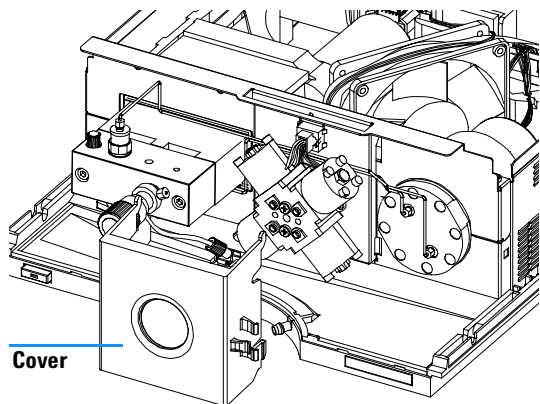

**12** Replace the pump on stack, reconnect all tubings and cables.

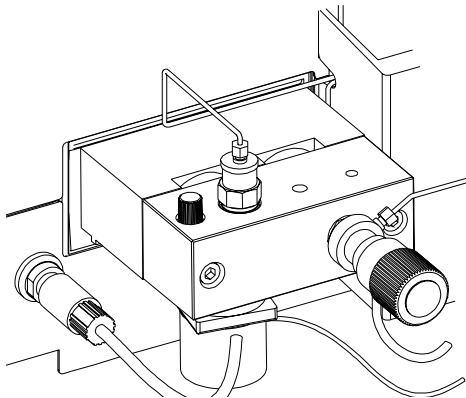

## 4 Repairing the Pump

### Exchanging the Power Supply

**When required**  
**Tools required**

Error message: Motor Drive Power  
Screwdriver Pozidriv #1  
Wrench 1/4 inch  
Wrench 14 mm  
Wrench 7 mm  
Wrench 5 mm

**Parts required**  
**Preparations for this procedure**

Power supply 0950-2528  
Remove the pump from the stack. Remove the front cover, top cover and top foam section (see "Removing the Top Cover and Foam" on page 128

**1** Disconnect all capillaries, tubes and connectors from the pump head and the damper. Remove the MCDV cover.

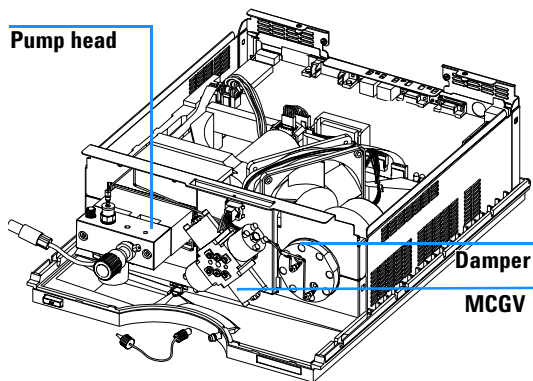

**2** Loosen the two Z-panel screws and remove it.

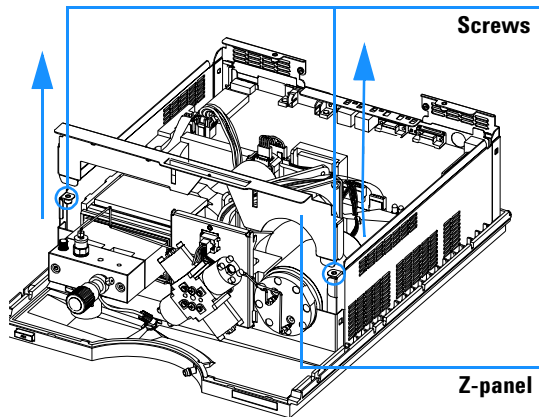

**3** Disconnect the connectors of the pump assembly (J16, J17), fan (J25) and damper (J24) at the main board and lift the three assemblies out of the foam. Disconnect all remaining connectors at the main board.

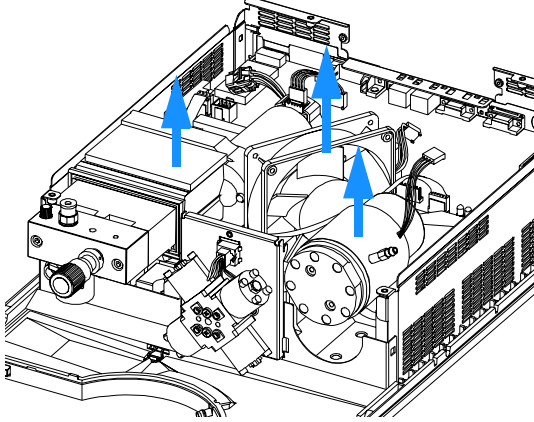

**4** Remove the LPM board, see "Exchanging the Low Pressure Pump Main Board (LPM Board)" on page 131.

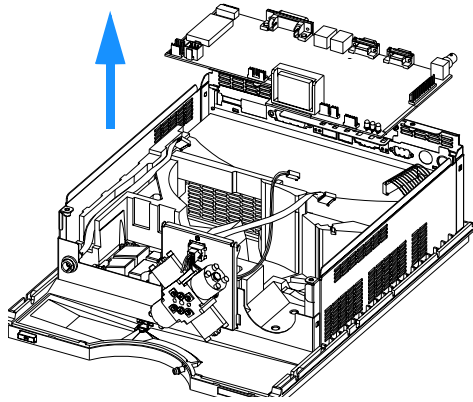

**5** Push the leak sensor cable through the recess in the foam and lift the bottom foam out of the instrument.

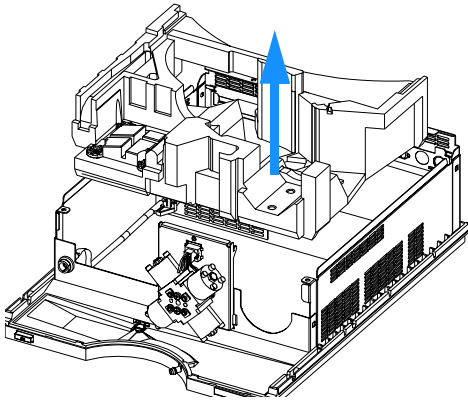

**6** Loosen and remove the power supply screws at the rear panel.

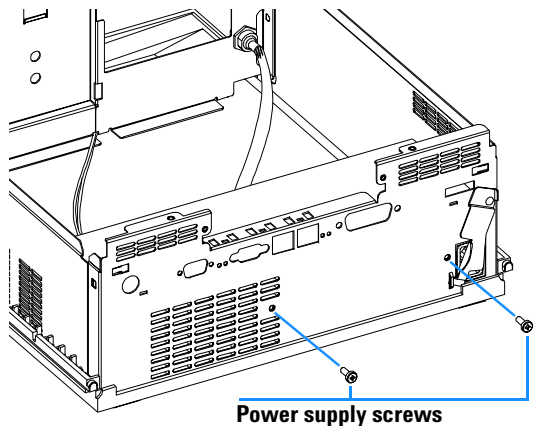

## 4 Repairing the Pump

**7** Unclip the power supply light pipe from the power supply and pull out the coupler.

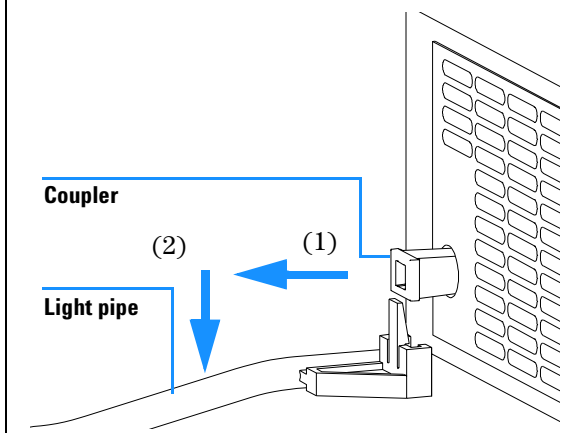

**8** Lift the power supply out of the unit.

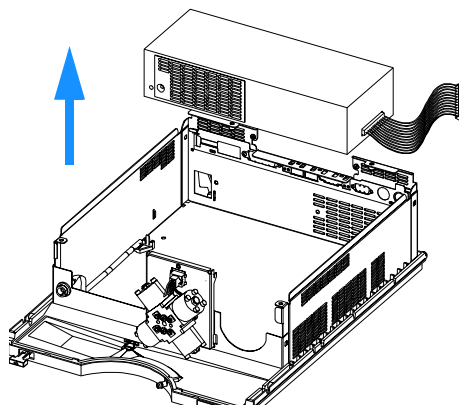

**9** Place the new power supply into the instrument and fix the two screws at the back plane.

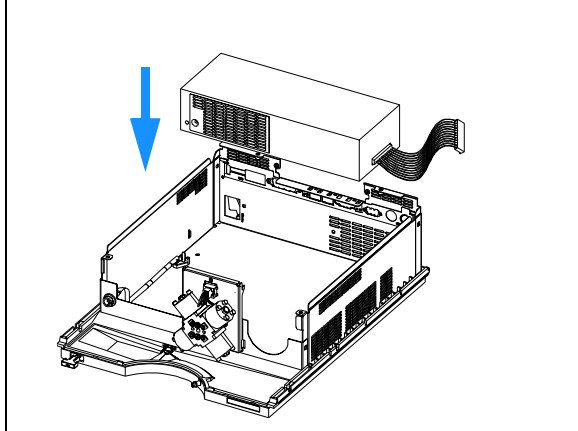

**10** Install the coupler onto the power supply switch and clip the light pipe back onto the coupler.

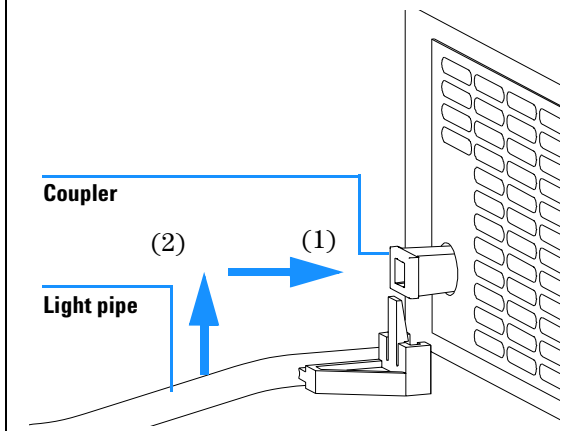

**11** Slide the leak sensor cable through the foam and replace the bottom foam.

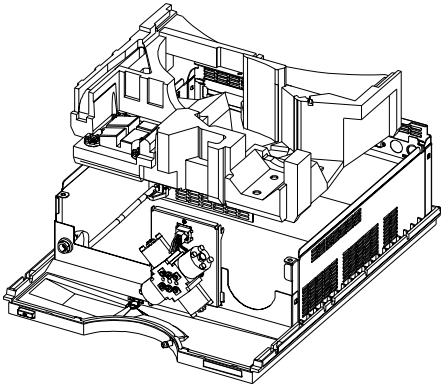

**12** Reinstall the main board, see "Exchanging the Low Pressure Pump Main Board (LPM Board)" on page 131.

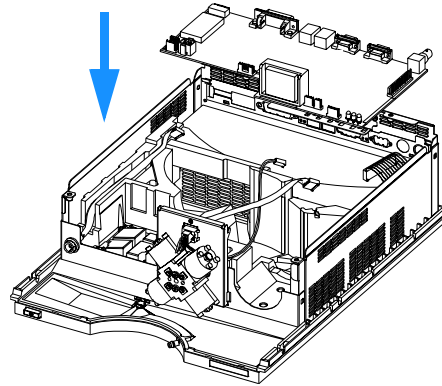

**13** Re-install pump assembly, fan and damper into the bottom foam and re-connect to the main board.

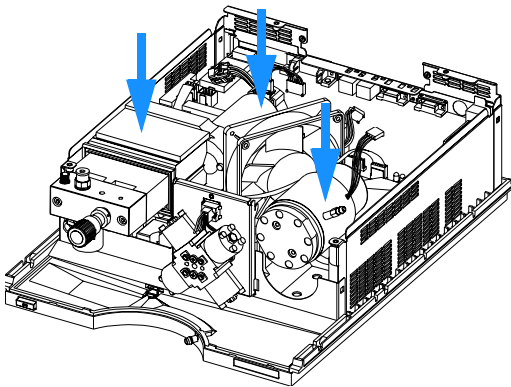

**14** Place the Z-panel into its position and tighten the two screws.

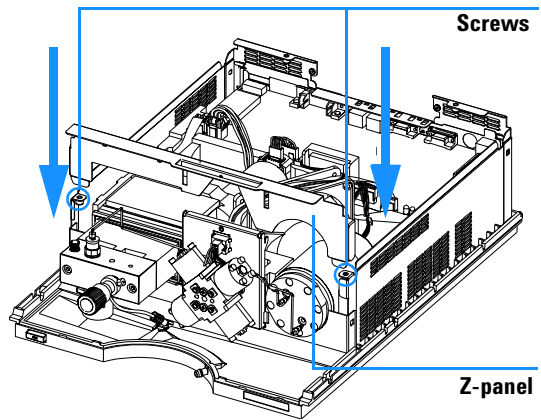

## 4 Repairing the Pump

**15** Clip the MCGV cover into position. Reconnect all capillaries, tubes and cables to the pump head, the MCGV and the damper.

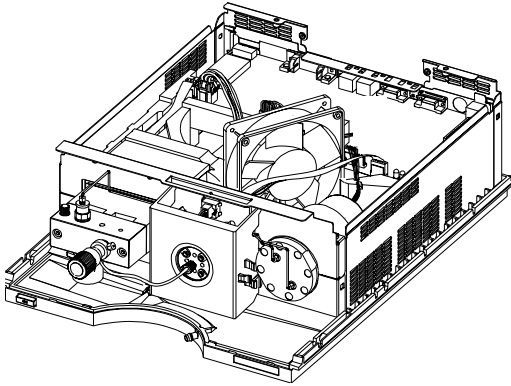

**16** Install foam and top cover, see "[Replacing the Top Cover and Foam](#)" on page 157. Replace the pump on stack, reconnect all tubings and cables.

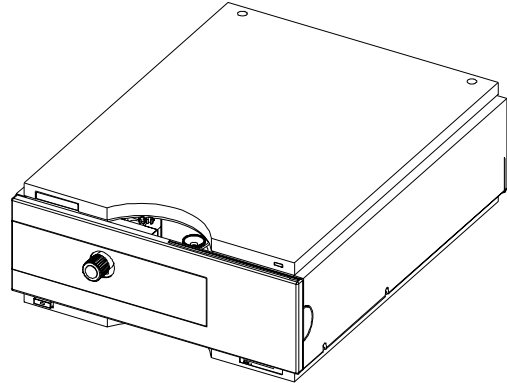



## Exchanging the Leak Sensor

<b>When required</b>	Leak messages without leak in the leak pan
<b>Tools required</b>	Screwdriver Pozidriv #1 Wrench 1/4 inch Wrench 14 mm Wrench 7 mm Wrench 5 mm
<b>Parts required</b>	Leak sensor 5061-3356

- 1 Switch off the pump at the main power switch, remove all cables and tubings, remove the pump from the stack.
- 2 Remove the top covers and foam, see ["Removing the Top Cover and Foam"](#) on page 128.
- 3 Remove pump assembly, fan, damper and the bottom foam, see ["Exchanging the Power Supply"](#) on page 148.
- 4 Remove the main board, see ["Exchanging the Low Pressure Pump Main Board \(LPM Board\)"](#) on page 131.
- 5 Unclip the leak pan and place it in front of the instrument.
- 6 Pull the leak sensor out of the leak pan and push the leak sensor cable and connector through the metal plate.
- 7 Push the connector of the new sensor through the metal plate.
- 8 Place the leak sensor into the leak pan, see [Figure 23](#) and clip the pan back into its position.
- 9 Reinstall the bottom foam. Make sure that the leak sensor cable is not covered by the foam.
- 10 Replace the main board, see ["Exchanging the Low Pressure Pump Main Board \(LPM Board\)"](#) on page 131.
- 11 Install the pump assembly, the fan, the damper and the Z-panel, see ["Exchanging the Power Supply"](#) on page 148. Reconnect all cables and capillaries.
- 12 Replace top foam and top cover, see ["Replacing the Top Cover and Foam"](#) on page 157.

## 4 Repairing the Pump

13 Replace the pump on stack, reconnect all tubings and cables.

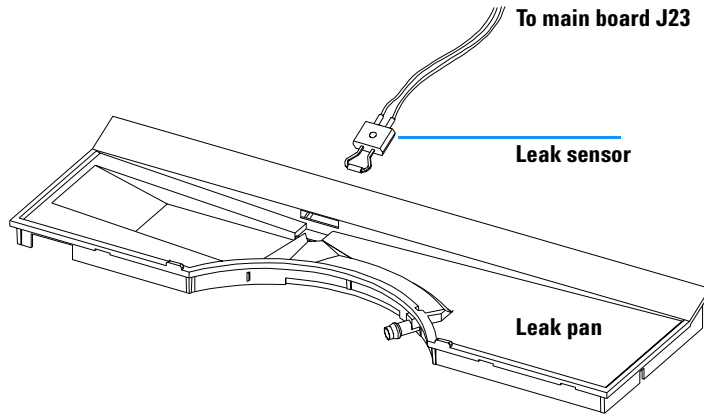

**Figure 23** Exchanging the Leak Sensor

## Exchanging the Status Light Pipe

**When required**

If part is broken

**Tools required**

Screwdriver Pozidriv #1

**Part required**

Status light pipe 5041-8384

**Preparation for this procedure**Remove the front cover and top cover, see "[Removing the Top Cover and Foam](#)" on page 128

1 The status light pipe is clipped into the top cover.

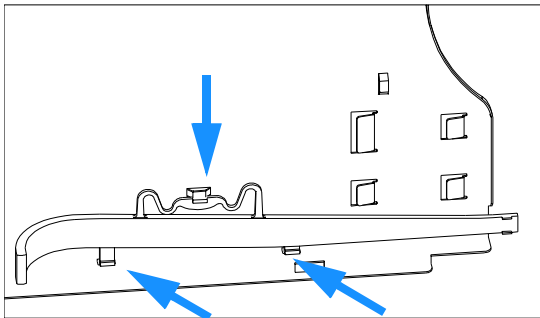

2 Replace the top cover, see "[Replacing the Top Cover and Foam](#)" on page 157.

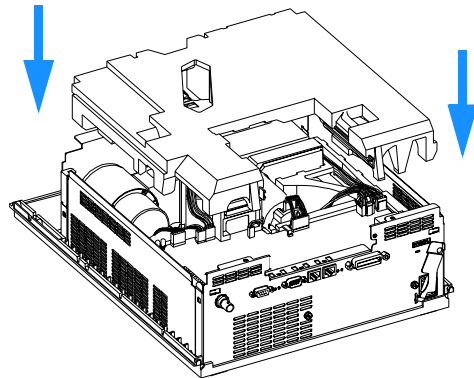

## 4 Repairing the Pump

### Assembling the Main Cover

<b>When required</b>	If cover is broken
<b>Tools required</b>	None
<b>Parts required</b>	Cover kit 5062-8565 (includes base, top, left and right)

#### NOTE

The cover kit contains all parts, but it is not assembled.

#### WARNING

In case you insert the left or right side in the opposite position, you may not be able to remove the side from the top part.

- 1** Place the top part on the bench and insert the left and right side into the top part.

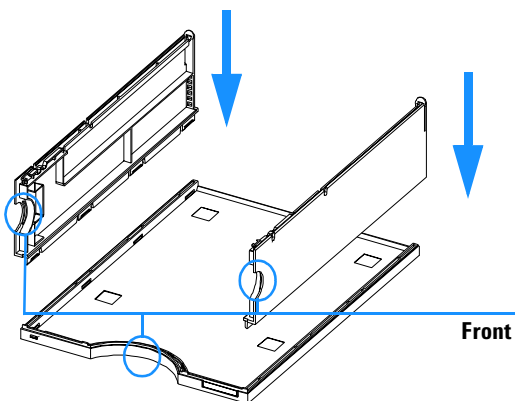

- 2** Replace the cover.

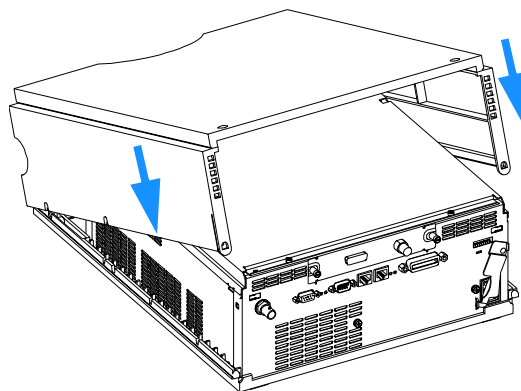

- 3** Replace the quaternary pump into the stack and reconnect the cables and capillaries.  
**4** Turn on the quaternary pump.

## Replacing the Top Cover and Foam

**Tools required**

Screwdriver Pozidriv #1

**Preparations for this procedure**

Make sure that after your repair all assemblies, cables, capillaries and connectors are located in its correct place.

**1** Replace the top foam section.

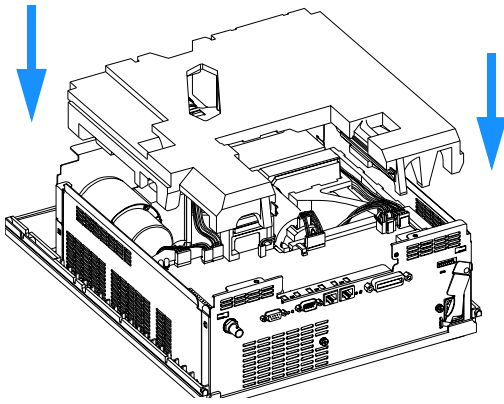

**2** Make sure that the foam is installed correctly and is located in the safety light switch.

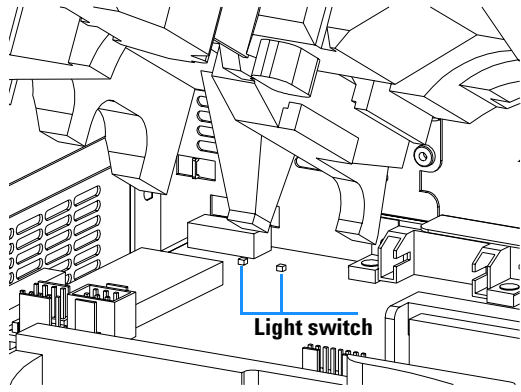

**3** Location of foam in the light switch.

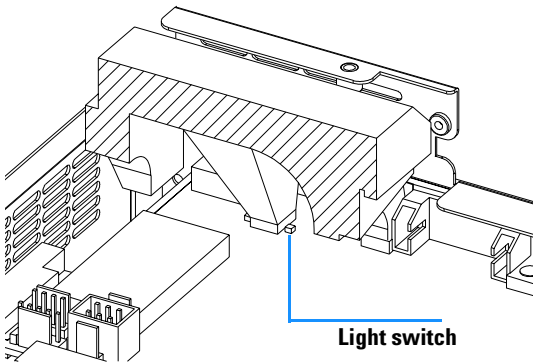

**4** Replace the optional interface board.

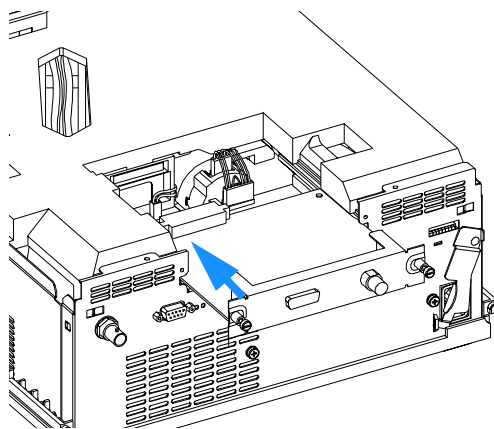

## 4 Repairing the Pump

**5** Replace the metal cover (slide the metal tabs into place (1) underneath the Z-Panel in the front, then lower the back of the metal plate (2)) and fix the two holding screws.

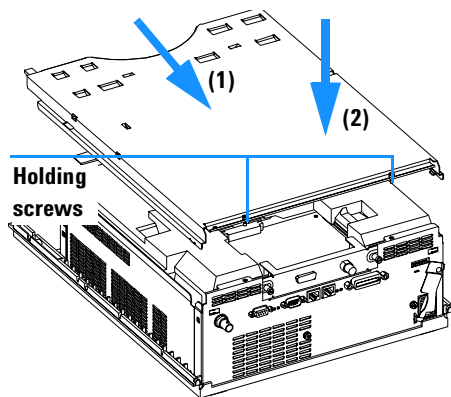

**6** Replace the top cover. Replace the pump on stack, reconnect all tubings and cables.

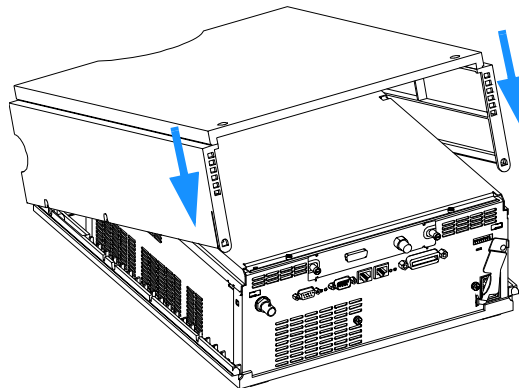

**7** Ensure clips are seated correctly and, move the lever back.

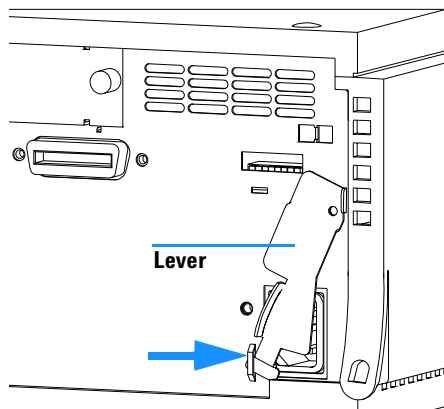

**8** Place the quaternary pump back to its position in the stack, place vacuum degasser and solvent cabinet back in place and re-connect all tubes and capillaries.

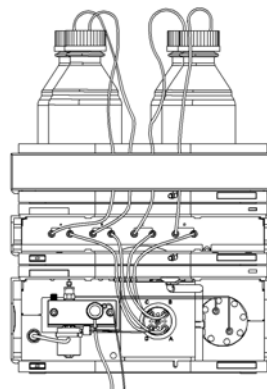

**9** Replace the leak funnel with the waste tube. Locate the lower end of the waste tube in the holder of the leak pan and clip tube to the holder at the gradient valve cover.

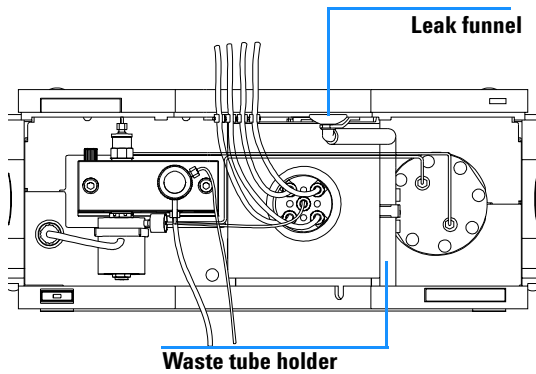

**10** Replace the front covers and reconnect the power cable to pump and on-line degasser and switch the modules on.

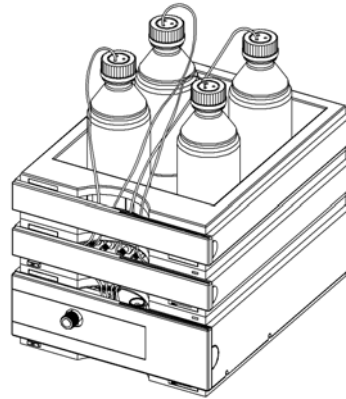

## **4 Repairing the Pump**



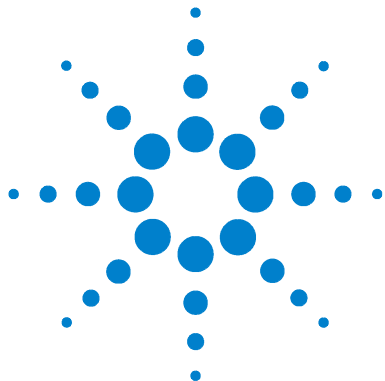

## 5 Parts and Materials

Overview of Main Assemblies	162
Control Module (B-version)	165
Solvent Cabinet	166
Bottle Head Assembly	167
Hydraulic Path	168
Cover Parts	169
Sheet Metal Kit	170
Foam Parts	171
Power and Status Light Pipes	172
Leak Parts	173
Pump Head Assembly	174
Pump Head Assembly with Seal Wash Option	176
Outlet Ball Valve Assembly	178
Purge Valve Assembly	179
Active Inlet Valve Assembly	180
Accessory Kit G1311-68705	181
Seal Wash Option Kit 01018-68722	182
Cable Overview	183
RS-232 Cable Kit	200
LAN Cables	201



## Overview of Main Assemblies

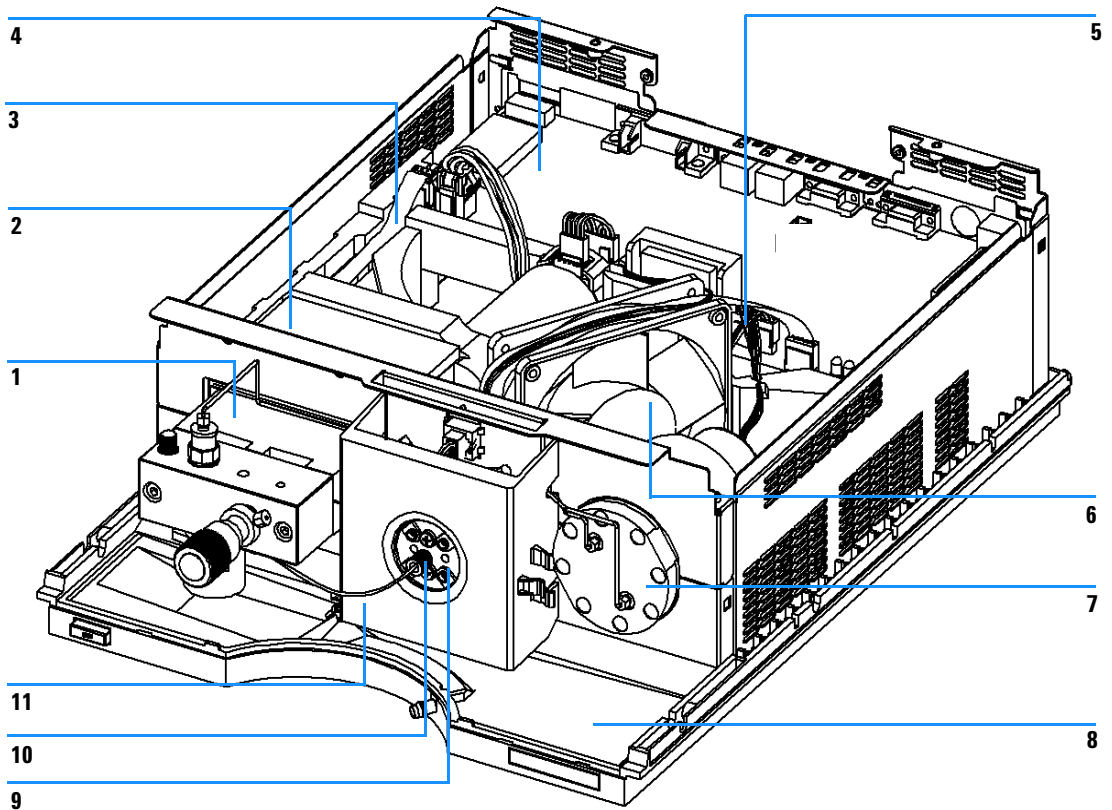

**Figure 24** Overview of Main Assemblies (Front View)

**Table 9** Repair Parts - Pump Housing and Main Assemblies (Front View)

Item	Description	Part Number
1	Pump head, see <a href="#">page 174</a>	G1311-60004
2	Pump drive assembly Exchange assembly — pump drive	G1311-60001 G1311-69001

**Table 9** Repair Parts - Pump Housing and Main Assemblies (Front View) (continued)

Item	Description	Part Number
3	Cable assembly — AIV to main board	G1311-61601
4	Low-pressure pump main board (LPM) Exchange assembly — LPM board	G1311-66520 G1311-69520
5	Cable to MCGV	G1311-61600
6	Fan assembly	3160-1016
7	Damping unit	79835-60005
8	Leak pan — pump	5041-8390
9	Multi-gradient assembly (MCGV) Exchange assembly — MCGV	G1311-67701 G1311-69701
10	Screw, M4, 40 mm lg — MCGV	0515-0906
--	Rubber holder — MCGV	1520-0401
11	MCGV cover	G1311-44101

## 5 Parts and Materials

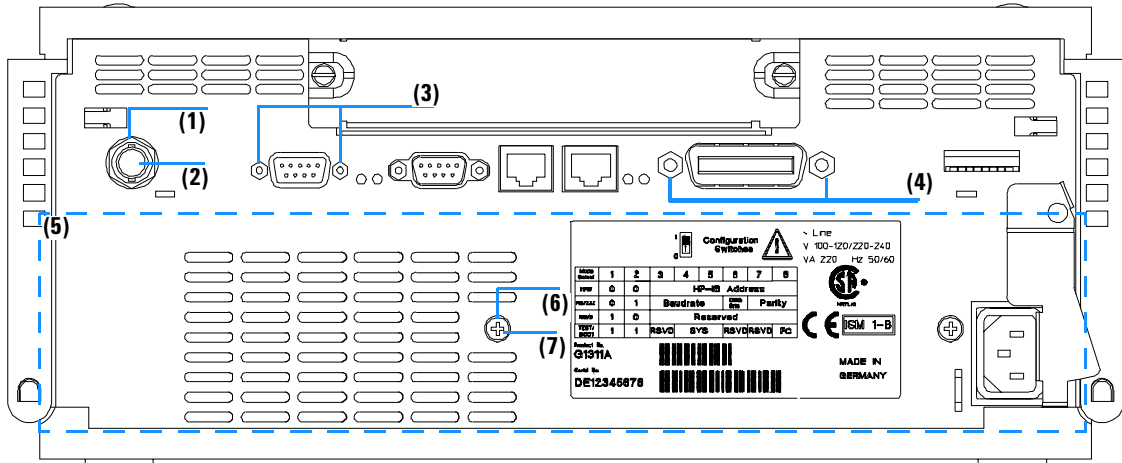

**Figure 25** Overview of Main Assemblies (Rear View)

**Table 10** Repair Parts - Pump Housing and Main Assemblies (Rear View)

Item	Description	Part Number
1	Nut M14 — analog output	2940-0256
2	Washer — analog output	2190-0699
3	Standoff — remote connector	1251-7788
4	Standoff — GPIB connector	0380-0643
5	Power supply (behind rear panel)	0950-2528
6	Screw, M4, 7 mm lg — power supply	0515-0910
7	Washer — power supply	2190-0409

## Control Module (B-version)

**Table 11** Control Module (B-version)

Item	Description	Part Number
	Control module, replacement part including cable	G1323-67001
	Plastic Housing Kit, includes front, back and a clamp	5062-8583
	CAN cable, Agilent 1100 module to control module	G1323-81600

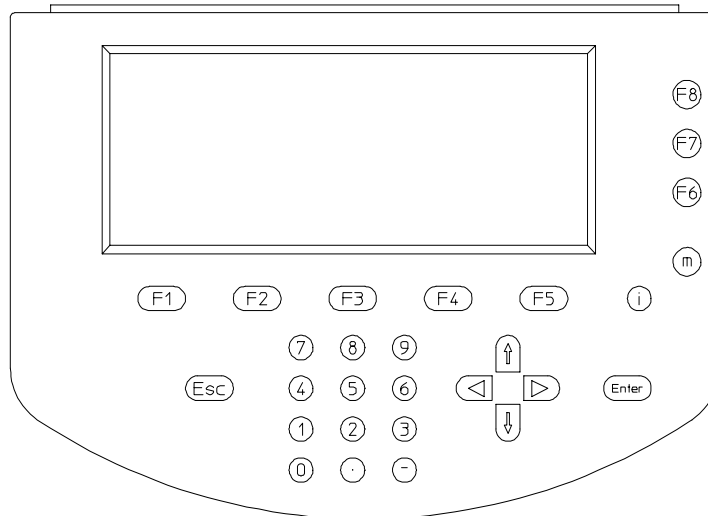
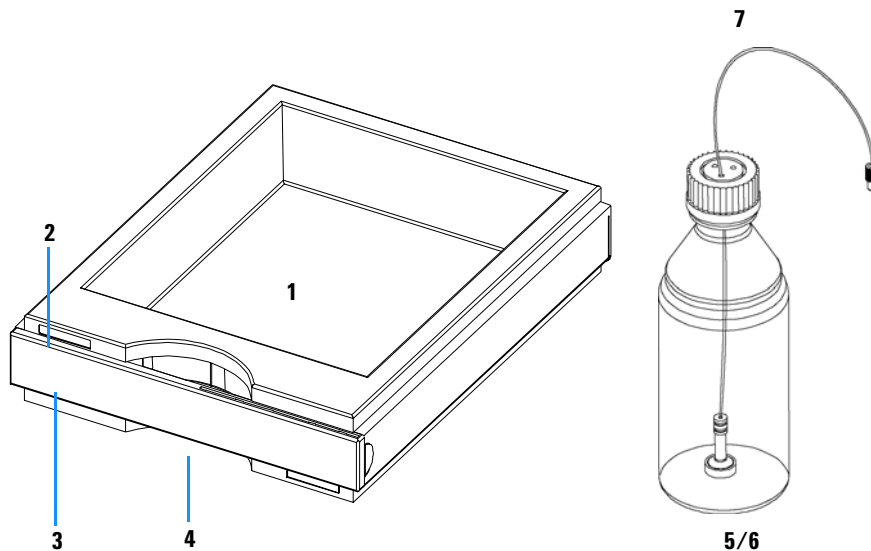

**Figure 26** Control Module B-version

## Solvent Cabinet

**Table 12** Solvent Cabinet Parts

Item	Description	Part Number
1	Solvent cabinet, including all plastic parts	5062-8581
2	Name plate, Agilent 1100	5042-1381
3	Front panel, solvent cabinet	5062-8580
4	Leak pan, solvent cabinet	5042-1307
5	Bottle transparent	9301-1420
6	Bottle amber	9301-1450
7	Bottle-head assembly, see <a href="#">page 167</a>	G1311-60003

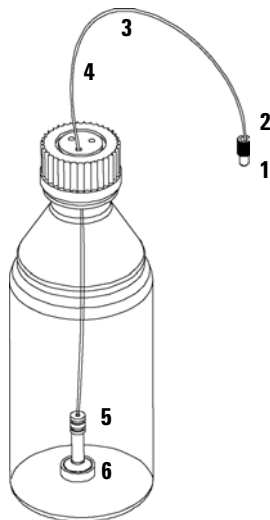

**Figure 27** Solvent Cabinet Parts

## Bottle Head Assembly

**Table 13** Bottle-Head Assembly Parts

Item	Description	Part Number
	Complete assembly	G1311-60003
1	Ferrules with lock ring	5063-6598 (10x)
2	Tube screw	5063-6599 (10x)
3	Wire marker	No part number
4	Solvent tubing, 5 m	5062-2483
5	Frit adapter (pack of 4)	5062-8517
6	Solvent inlet filter, 20 $\mu$ m	5041-2168

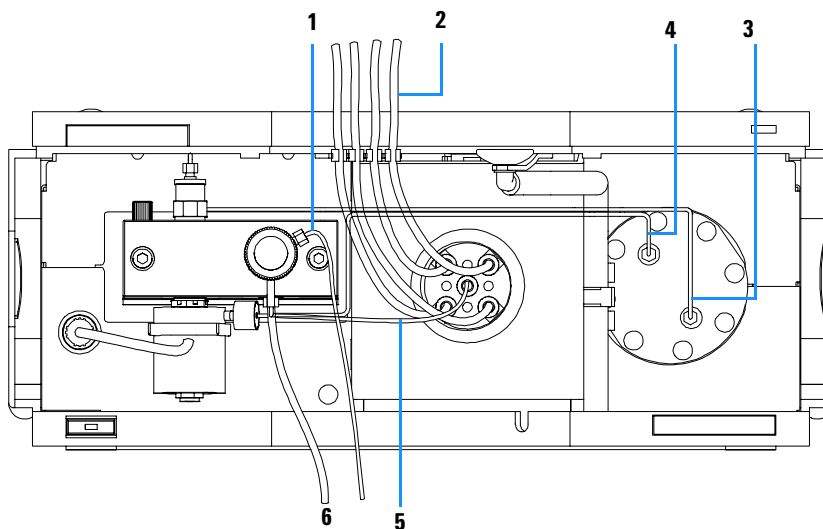

**Figure 28** Bottle-Head Assembly Parts

## Hydraulic Path

**Table 14** Hydraulic Path

Item	Description	Part Number
1	Outlet capillary, pump to injector device	G1312-67305
	Outlet Capillary, pump to thermostatable autosampler	G1329-87300
	Bottle-head assembly, bottle to vacuum degasser (see " <a href="#">Bottle Head Assembly</a> " on page 167)	G1311-60003
2	Solvent tube, vacuum degasser to MCGV (pack of 4)	G1322-67300
3	Capillary, plunger 1 to damper	G1311-67301
4	Capillary, damper to plunger 2	G1311-67300
5	Connecting tube, MCGV to AIV	G1311-67304
6	Waste tube, reoder pack, 5 m	5062-2461



**Figure 29** Hydraulic Flow Path of the Quaternary Pump



## Cover Parts

**Table 15** Cover Parts

Item	Description	Part Number
1	Cover kit (includes top, both sides, base)	5062-8565
2	Front plate	5062-8566
3	Logo plate, Agilent 1100	5042-1381

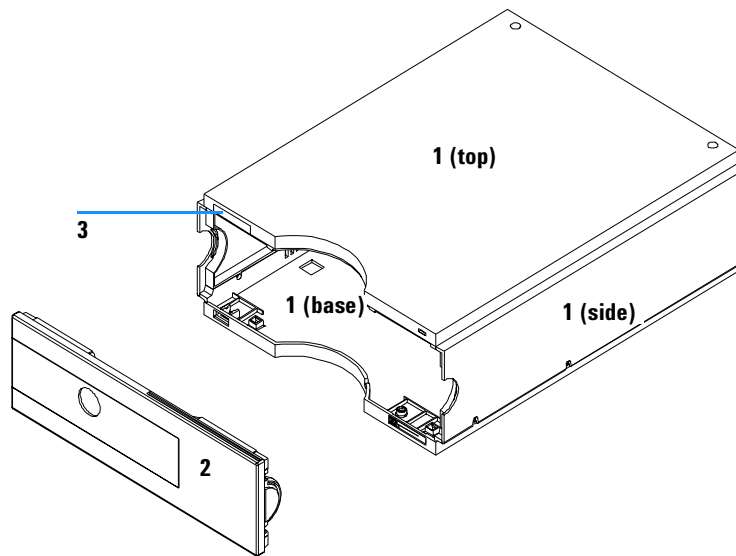
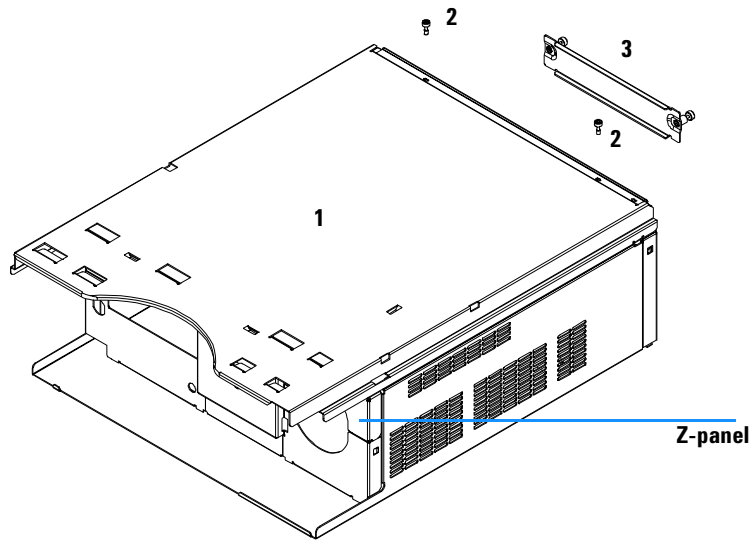

**Figure 30** Cover Parts

## Sheet Metal Kit

**Table 16** Sheet Metal Kit

Item	Description	Part Number
1	Sheet metal kit, includes top, base and Z-panel	G1311-68701
2	Screw, for cover and Z-Panel	5022-2112
3	Board cover	5001-3772

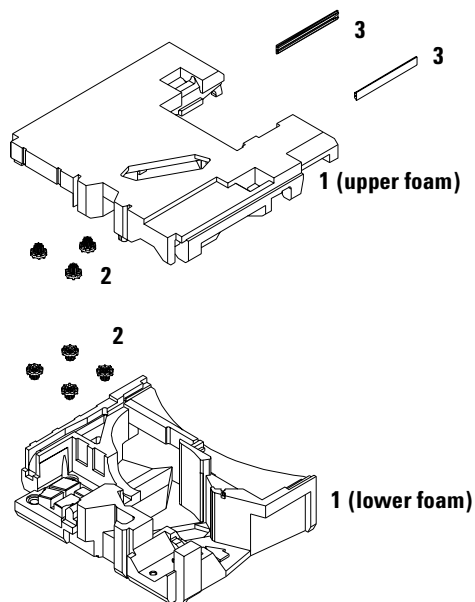

**Figure 31** Sheet Metal Kit

## Foam Parts

**Table 17** Foam Parts

Item	Description	Part Number
1	Foam Kit (includes upper and lower foam)	<a href="#">G1311-68702</a>
2	Bushing, for pump drive	<a href="#">1520-0404</a>
3	Board Guides	<a href="#">5041-8395</a>

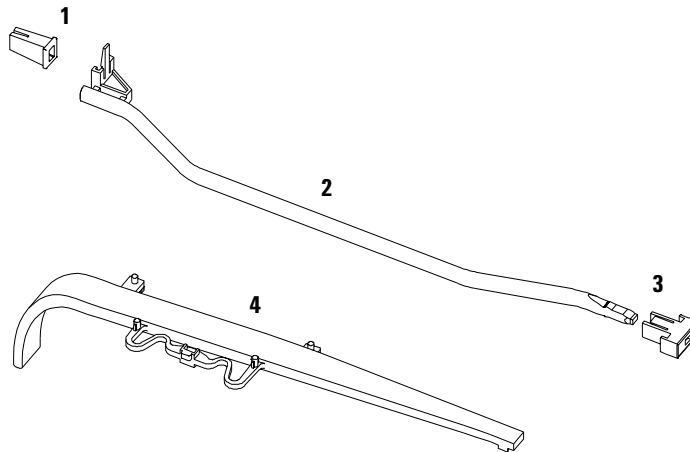

**Figure 32** Foam Parts

## Power and Status Light Pipes

**Table 18** Power and Status Light Pipes

Item	Description	Part Number
1	Power switch coupler	5041-8383
2	Light pipe — power switch	5041-8382
3	Power switch button	5041-8381
4	Light pipe — status lamp	5041-8384

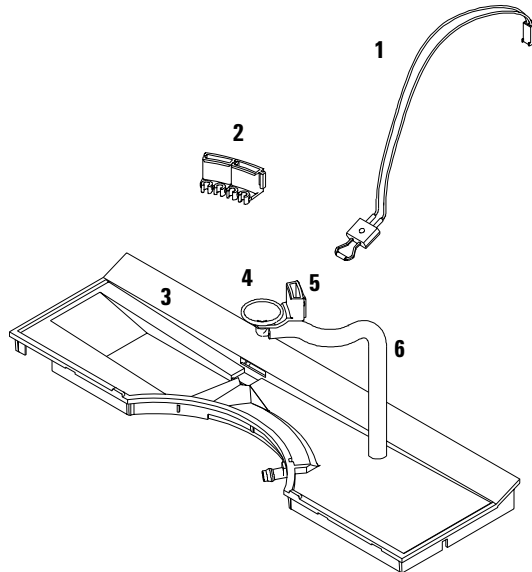

**Figure 33** Power and Status Light Pipes

## Leak Parts

**Table 19** Leak Parts

Item	Description	Part Number
1	Leak sensor	5061-3356
2	Tube clip	5041-8387
3	Leak pan, pump	5041-8390
4	Leak funnel	5041-8388
5	Holder, leak funnel	5041-8389
6	Corrugated waste tube (reorder pack), 5m	5062-2463

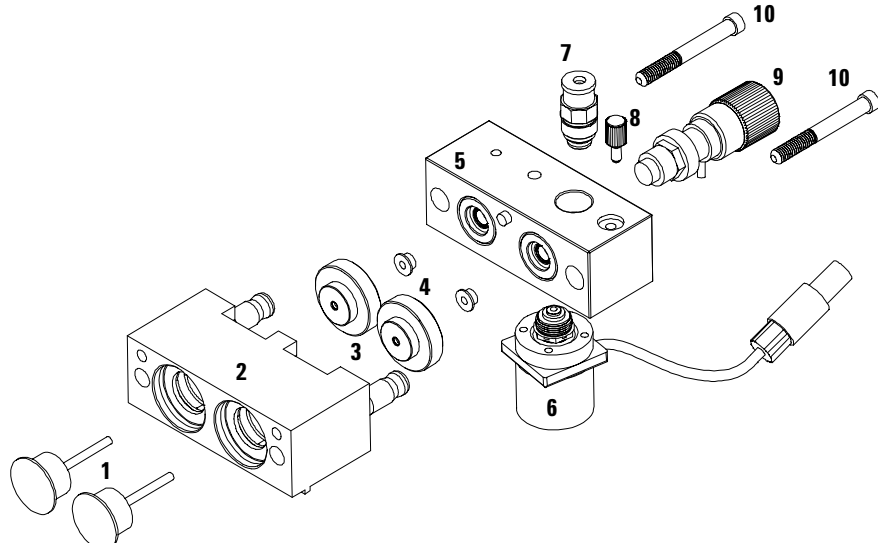

**Figure 34** Leak Parts

## Pump Head Assembly

**Table 20** Pump Head Assembly

Item	Description	Part Number
	Complete assembly, including items marked with *	G1311-60004
1*	Sapphire plunger	5063-6586
2*	Plunger housing (including spring)	G1311-60002
3*	Support ring	5001-3739
4*	Seal (pack of 2) <u>or</u> Seal (pack of 2), for normal phase applications	5063-6589 0905-1420
5*	Pump chamber housing	G1311-25200
6	Active inlet valve (complete with cartridge)	G1312-60010
	Replacement cartridge for active inlet valve	5062-8562
7	Outlet ball valve	G1311-60012
8*	Screw lock	5042-1303
9	Purge valve assembly	G1311-60009
10*	Screw M5, 60 mm lg	0515-2118



**Figure 35** Pump Head Assembly

## Pump Head Assembly with Seal Wash Option

**Table 21** Pump Head Assembly with Seal Wash Option

Item	Description	Part Number
	Complete assembly, including parts marked with *	G1311-60005
1*	Sapphire plunger	5063-6586
2*	Plunger housing (including spring)	G1311-60002
3*	Support ring, seal wash	5062-2465
4*	Secondary seal	0905-1175
5*	Wash tube (1.0 m)	0890-1764
6*	Gasket, seal wash (pack of 6)	5062-2484
7*	Seal keeper	5001-3743
8*	Seal (pack of 2) <b>or</b> Seal (pack of 2), for normal phase applications	5063-6589 0905-1420
9*	Pump chamber housing	G1311-25200
10	Active inlet valve	G1312-60010
	Replacement cartridge for active inlet valve	5062-8562
11	Outlet ball valve (complete with cartridge)	G1311-60012
12*	Screw lock	5042-1303
13	Purge valve	G1311-60009
14*	Screw M5, 60 mm lg	0515-2118
	Seal wash upgrade kit (see <a href="#">page 182</a> )	01018-68722



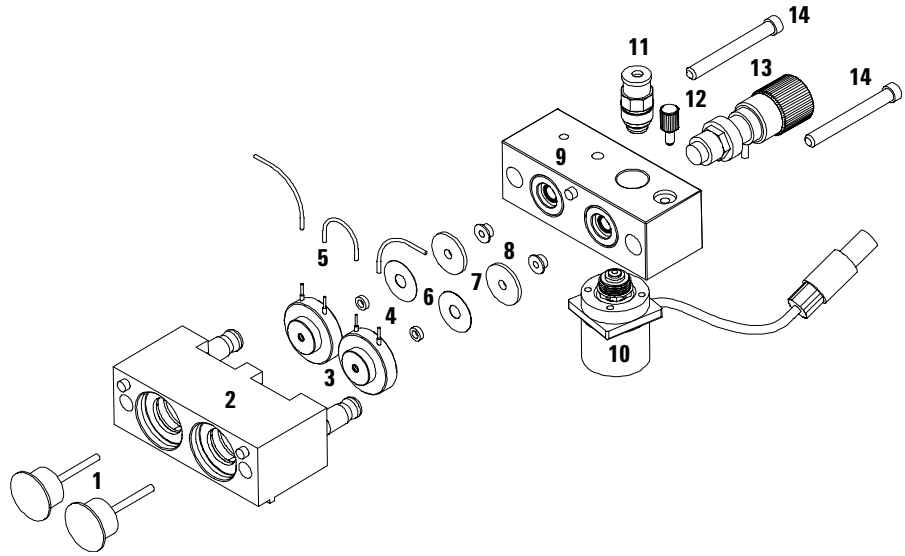
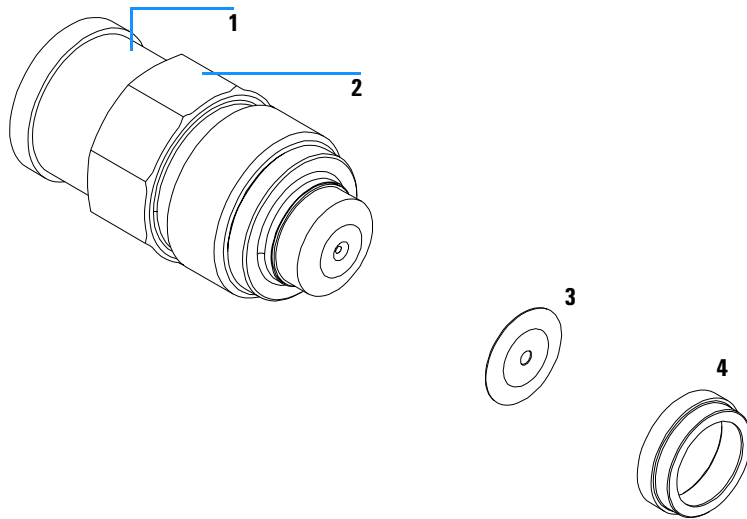

**Figure 36** Pump Head with Seal Wash Option

## Outlet Ball Valve Assembly

**Table 22** Outlet Ball Valve Assembly

Item	Description	Part Number
	Outlet ball valve — complete assembly	G1311-60012
1	Socket cap	5042-1345
2	Outlet valve housing screw	01018-22410
3	Gold seal, outlet	5001-3707
4	Cap (pack of 4)	5062-2485

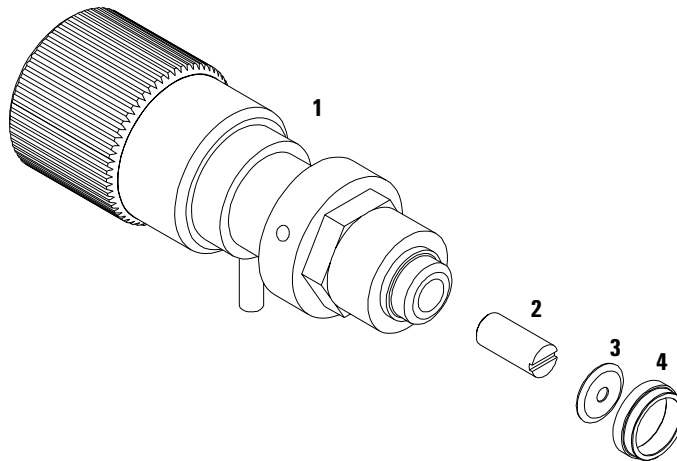

**Figure 37** Outlet Ball Valve Assembly

## Purge Valve Assembly

**Table 23** Purge-Valve Assembly

Item	Description	Part Number
	Purge valve — complete assembly	<a href="#">G1311-60009</a>
1	Valve body	No part number
2	PTFE frit (pack of 5)	<a href="#">01018-22707</a>
3	Gold seal	<a href="#">5001-3707</a>
4	Cap (pack of 4)	<a href="#">5062-2485</a>

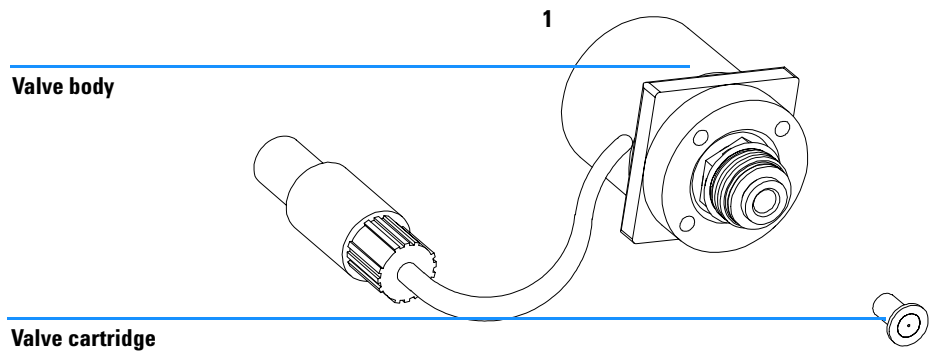

**Figure 38** Purge-Valve Assembly

## Active Inlet Valve Assembly

**Table 24** Active Inlet Valve Assembly

Item	Description	Part Number
	Active inlet valve — complete assembly	G1312-60010
1	Valve body	No part number
2	Valve cartridge	5062-8562



**Figure 39** Active Inlet Valve Assembly

## Accessory Kit G1311-68705

**Table 25** Tools and Accessories

Description	Part Number
Wrench 14 mm	8710-1924
Seal insert tool	01018-23702
PTFE Frit (pack of 5)	01018-22707
Corrugated waste tube (1.2 m)	no PN
Corrugated waste tube (reorder number), 5m	5062-2463
Velocity regulator (reorder number, 3)	5062-2486
ESD wrist strap	9300-1408
Hex key 4mm	8710-2392
Wrench 1/4 – 5/16 inch	8710-0510
Capillary, pump to injection device, 600 mm lg, ID 0.17 mm	G1312-67305

## Seal Wash Option Kit 01018-68722

**Table 26** Seal Wash Option

Description	Part Number
Support ring, seal wash (pack of 2)	5062-2465
Secondary seal (pre-installed in support ring)	0905-1175
Seal keeper (pack of 2)	5001-3743
Wash tube (1m)	0890-1764
Velocity regulator <sup>*</sup>	5062-2486
Seals insert tool	01018-23702
Seal (pack of 2)	5063-6589
Syringe <sup>**</sup>	5062-8534
Syringe adapter	0100-1681
Knife	no PN
Sanding Paper	no PN

\* Reorder number (pack of 3)

\*\* Reorder number (pack of 10)

## Cable Overview

**WARNING**

Never use cables other than the ones supplied by Agilent Technologies to ensure proper functionality and compliance with safety or EMC regulations.

**Table 27** Cables Overview

Type	Description	Part Number
Analog cables	3390/2/3 integrators	01040-60101
	3394/6 integrators	35900-60750
	Agilent 35900A A/D converter	35900-60750
	General purpose (spade lugs)	01046-60105
Remote cables	3390 integrator	01046-60203
	3392/3 integrators	01046-60206
	3394 integrator	01046-60210
	3396A (Series I) integrator	03394-60600
	3396 Series II / 3395A integrator, see <a href="#">page 190</a>	
	3396 Series III / 3395B integrator	03396-61010
	HP 1050 modules / HP 1046A FLD	5061-3378
	HP 1046A FLD	5061-3378
	Agilent 35900A A/D converter	5061-3378
	HP 1040 diode-array detector	01046-60202
	HP 1090 liquid chromatographs	01046-60202
	Signal distribution module	01046-60202
	<b>BCD cables</b>	3392/3 integrators

**Table 27** Cables Overview (continued)

<b>Type</b>	<b>Description</b>	<b>Part Number</b>
	3396 integrator	03396-60560
	General purpose (spade Lugs)	18594-60520
<b>Auxiliary</b>	Agilent 1100 Series vacuum degasser	G1322-61600
<b>CAN cables</b>	Agilent 1100 module to module, 0.5m lg	5181-1516
	Agilent 1100 module to module, 1m lg	5181-1519
	Agilent 1100 module to control module	G1323-81600
<b>External contacts</b>	Agilent 1100 Series interface board to general purpose	G1103-61611
<b>GPIB cable</b>	Agilent 1100 module to ChemStation, 1 m	10833A
	Agilent 1100 module to ChemStation, 2 m	10833B
<b>RS-232 cable</b>	Agilent 1100 module to a computer This kit contains a 9-pin female to 9-pin female Null Modem (printer) cable and one adapter.	34398A
<b>LAN cable</b>	Twisted pair cross over LAN cable, 10 feet long (for point to point connection)	5183-4649
	Category 5 UTP cable, 8 m long (for hub connections)	G1530-61480



## Analog Cables

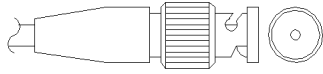

One end of these cables provides a BNC connector to be connected to Agilent 1100 Series modules. The other end depends on the instrument to which connection is being made.

### Agilent 1100 to 3390/2/3 Integrators

Table 28

Connector <b>01040-60101</b>	Pin <b>3390/2/3</b>	Pin <b>Agilent 1100</b>	Signal Name
	1	Shield	Ground
	2		Not connected
	3	Center	Signal +
	4		Connected to pin 6
	5	Shield	Analog -
	6		Connected to pin 4
	7		Key
	8		Not connected

### Agilent 1100 to 3394/6 Integrators

Table 29

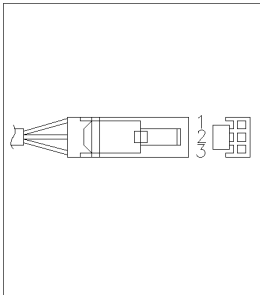
Connector <b>35900-60750</b>	Pin <b>3394/6</b>	Pin <b>Agilent 1100</b>	Signal Name
	1		Not connected
	2	Shield	Analog -
	3	Center	Analog +

### Agilent 1100 to BNC Connector

Table 30

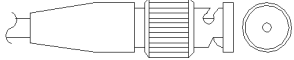
Connector <b>8120-1840</b>	Pin <b>BNC</b>	Pin <b>Agilent 1100</b>	Signal Name
	Shield	Shield	Analog -
	Center	Center	Analog +

**Agilent 1100 to General Purpose**

**Table 31**

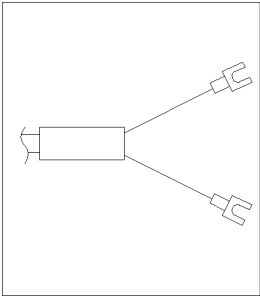
Connector 01046-60105	Pin 3394/6	Pin Agilent 1100	Signal Name
	1		Not connected
	2	Black	Analog -
	3	Red	Analog +

## Remote Cables



One end of these cables provides a Agilent Technologies APG (Analytical Products Group) remote connector to be connected to Agilent 1100 Series modules. The other end depends on the instrument to be connected to.

### Agilent 1100 to 3390 Integrators

Table 32

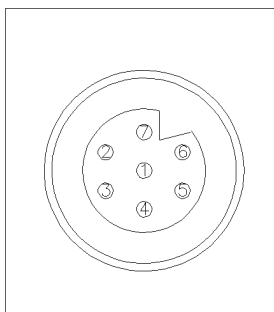
Connector <b>01046-60203</b>	Pin <b>3390</b>	Pin <b>Agilent 1100</b>	Signal Name	Active (TTL)
	2	1 - White	Digital ground	
	NC	2 - Brown	Prepare run	Low
	7	3 - Gray	Start	Low
	NC	4 - Blue	Shut down	Low
	NC	5 - Pink	Not connected	
	NC	6 - Yellow	Power on	High
	NC	7 - Red	Ready	High
	NC	8 - Green	Stop	Low
	NC	9 - Black	Start request	Low

### Agilent 1100 to 3392/3 Integrators

Table 33

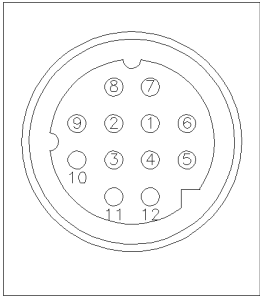
Connector 01046-60206	Pin 3392/3	Pin Agilent 1100	Signal Name	Active (TTL)
 <p>4 - Key</p>	3	1 - White	Digital ground	
	NC	2 - Brown	Prepare run	Low
	11	3 - Gray	Start	Low
	NC	4 - Blue	Shut down	Low
	NC	5 - Pink	Not connected	
	NC	6 - Yellow	Power on	High
	9	7 - Red	Ready	High
	1	8 - Green	Stop	Low
	NC	9 - Black	Start request	Low

### Agilent 1100 to 3394 Integrators

Table 34

Connector 01046-60210	Pin 3394	Pin Agilent 1100	Signal Name	Active (TTL)
	9	1 - White	Digital ground	
	NC	2 - Brown	Prepare run	Low
	3	3 - Gray	Start	Low
	NC	4 - Blue	Shut down	Low
	NC	5 - Pink	Not connected	
	NC	6 - Yellow	Power on	High
	5,14	7 - Red	Ready	High
	6	8 - Green	Stop	Low
	1	9 - Black	Start request	Low

Table 34

Connector <b>01046-60210</b>	Pin <b>3394</b>	Pin <b>Agilent 1100</b>	Signal Name	Active (TTL)
	13, 15		Not connected	

**NOTE**

START and STOP are connected via diodes to pin 3 of the 3394 connector.

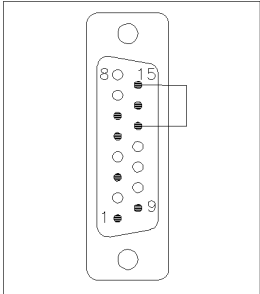
**Agilent 1100 to 3396A Integrators**

Table 35

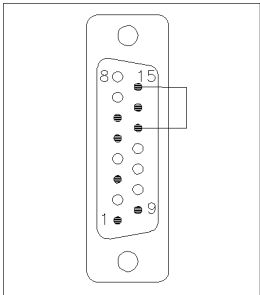
Connector <b>03394-60600</b>	Pin <b>3394</b>	Pin <b>Agilent 1100</b>	Signal Name	Active (TTL)
	9	1 - White	Digital ground	
	NC	2 - Brown	Prepare run	Low
	3	3 - Gray	Start	Low
	NC	4 - Blue	Shut down	Low
	NC	5 - Pink	Not connected	
	NC	6 - Yellow	Power on	High
	5,14	7 - Red	Ready	High
	1	8 - Green	Stop	Low
	NC	9 - Black	Start request	Low
	13, 15		Not connected	

**Agilent 1100 to 3396 Series II / 3395A Integrators**

Use the cable **03394-60600** and cut pin #5 on the integrator side. Otherwise the integrator prints START; not ready.

## Agilent 1100 to 3396 Series III / 3395B Integrators

Table 36

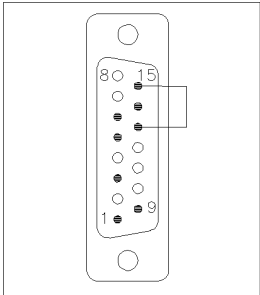
Connector 03396-61010	Pin 33XX	Pin Agilent 1100	Signal Name	Active (TTL)
	9	1 - White	Digital ground	
	NC	2 - Brown	Prepare run	Low
	3	3 - Gray	Start	Low
	NC	4 - Blue	Shut down	Low
	NC	5 - Pink	Not connected	
	NC	6 - Yellow	Power on	High
	14	7 - Red	Ready	High
	4	8 - Green	Stop	Low
	NC	9 - Black	Start request	Low
	13, 15		Not connected	

**Agilent 1100 to HP 1050, HP 1046A or Agilent 35900 A/D Converters**

**Table 37**

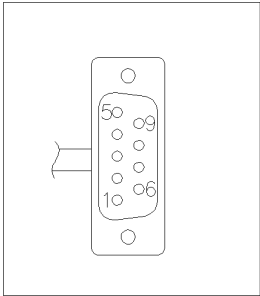
Connector <b>5061-3378</b>	Pin HP 1050/....	Pin Agilent 1100	Signal Name	Active (TTL)
	1 - White	1 - White	Digital ground	
	2 - Brown	2 - Brown	Prepare run	Low
	3 - Gray	3 - Gray	Start	Low
	4 - Blue	4 - Blue	Shut down	Low
	5 - Pink	5 - Pink	Not connected	
	6 - Yellow	6 - Yellow	Power on	High
	7 - Red	7 - Red	Ready	High
	8 - Green	8 - Green	Stop	Low
	9 - Black	9 - Black	Start request	Low

**Agilent 1100 to HP 1090 LC, HP 1040 DAD or Signal Distribution Module**

**Table 38**

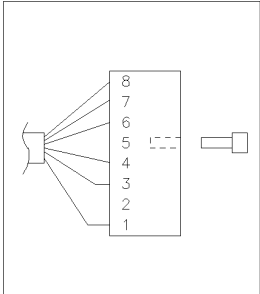
Connector <b>01046-60202</b>	Pin HP 1090	Pin Agilent 1100	Signal Name	Active (TTL)
 <p>5 - Key</p>	1	1 - White	Digital ground	
	NC	2 - Brown	Prepare run	Low
	4	3 - Gray	Start	Low
	7	4 - Blue	Shut down	Low
	8	5 - Pink	Not connected	
	NC	6 - Yellow	Power on	High
	3	7 - Red	Ready	High
	6	8 - Green	Stop	Low
	NC	9 - Black	Start request	Low



Agilent 1100 to General Purpose

Table 39

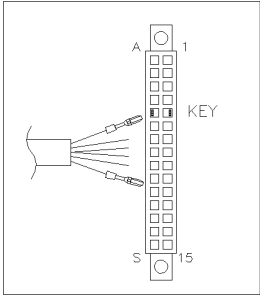
Connector 01046-60201	Pin Universal	Pin Agilent 1100	Signal Name	Active (TTL)
		1 - White	Digital ground	
		2 - Brown	Prepare run	Low
		3 - Gray	Start	Low
		4 - Blue	Shut down	Low
		5 - Pink	Not connected	
		6 - Yellow	Power on	High
		7 - Red	Ready	High
		8 - Green	Stop	Low
		9 - Black	Start request	Low

## BCD Cables



One end of these cables provides a 15-pin BCD connector to be connected to the Agilent 1100 Series modules. The other end depends on the instrument to be connected to.

### Agilent 1100 to 3392/3 Integrators

Table 40

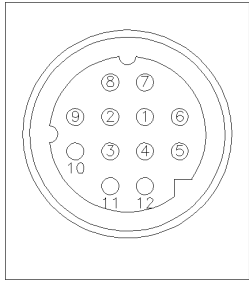
Connector <b>18584-60510</b>	Pin <b>3392/3</b>	Pin <b>Agilent 1100</b>	Signal Name	BCD Digit
 <p>6 - Key</p>	10	1	BCD 5	20
	11	2	BCD 7	80
	3	3	BCD 6	40
	9	4	BCD 4	10
	7	5	BCD 0\	1
	5	6	BCD 3	8
	12	7	BCD 2	4
	4	8	BCD 1	2
	1	9	Digital ground	
	2	15	+ 5 V	Low

## Agilent 1100 to 3396 Integrators

Table 41

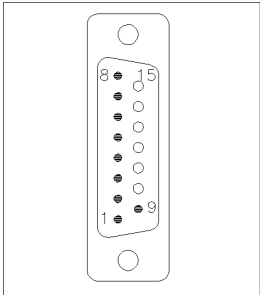
Connector 03396-60560	Pin 3392/3	Pin Agilent 1100	Signal Name	BCD Digit
	1	1	BCD 5	20
	2	2	BCD 7	80
	3	3	BCD 6	40
	4	4	BCD 4	10
	5	5	BCD 0\	1
	6	6	BCD 3	8
	7	7	BCD 2	4
	8	8	BCD 1	2
	9	9	Digital ground	
	NC	15	+ 5 V	Low

**Agilent 1100 to General Purpose**

**Table 42**

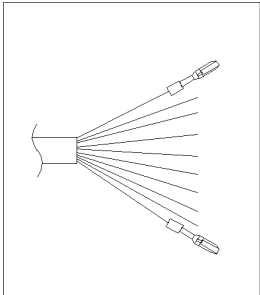
Connector 18594-60520	Wire Color	Pin Agilent 1100	Signal Name	BCD Digit
	Green	1	BCD 5	20
	Violet	2	BCD 7	80
	Blue	3	BCD 6	40
	Yellow	4	BCD 4	10
	Black	5	BCD 0\	1
	Orange	6	BCD 3	8
	Red	7	BCD 2	4
	Brown	8	BCD 1	2
	Gray	9	Digital ground	
	White	15	+5 Vt	Low

## Auxiliary Cable

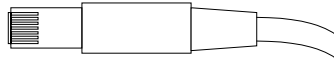

One end of this cable provides a modular plug to be connected to the Agilent 1100 Series vacuum degasser. The other end is for general purpose.

### Agilent 1100 Series Degasser to general purposes

Table 43

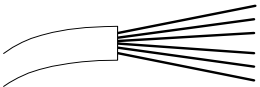
Connector G1322-81600	Color	Pin Agilent 1100	Signal Name
	White	1	Ground
	Brown	2	Pressure signal
	Green	3	
	Yellow	4	
	Grey	5	DC + 5 V IN
	Pink	6	Vent

## CAN Cable

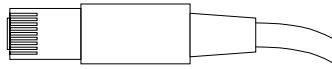

Both ends of this cable provide a modular plug to be connected to Agilent 1100 Series module's CAN-bus connectors.

**Table 44**

Agilent 1100 module to module, 0.5m lg	<a href="#">5181-1516</a>
Agilent 1100 module to module, 1m lg	<a href="#">5181-1519</a>
Agilent 1100 module to control module	<a href="#">G1323-81600</a>

## External Contact Cable

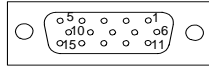

One end of this cable provides a 15-pin plug to be connected to Agilent 1100 Series module's interface board. The other end is for general purpose.

### Agilent 1100 Series Interface Board to general purposes

Table 45

Connector <b>G1103-61611</b>	Color	Pin Agilent 1100	Signal Name
	White	1	EXT 1
	Brown	2	EXT 1
	Green	3	EXT 2
	Yellow	4	EXT 2
	Grey	5	EXT 3
	Pink	6	EXT 3
	Blue	7	EXT 4
	Red	8	EXT 4
	Black	9	Not connected
	Violet	10	Not connected
	Grey/pink	11	Not connected
	Red/blue	12	Not connected
	White/green	13	Not connected
	Brown/green	14	Not connected
	White/yellow	15	Not connected

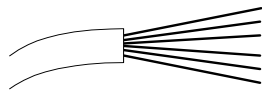

## RS-232 Cable Kit

This kit contains a 9-pin female to 9-pin female Null Modem (printer) cable and one adapter. Use the cable and adapter to connect Agilent Technologies instruments with 9-pin male RS-232 connectors to most PCs or printers.

**Agilent 1100 module to PC**

**RS-232 Cable Kit [34398A](#)**

# Instrument

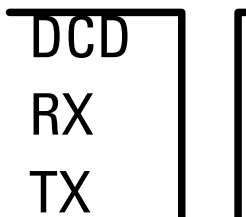

**Figure 40** RS-232 Cable



## LAN Cables

### Recommended Cables

For point to point connection (not using a network hub) use a twisted pair cross over LAN cable (P/N [5183-4649](#), 10 feet long).

For standard network connections using a hub use category 5 UTP cables, (P/N [G1530-61480](#), 8 m long).

## **5 Parts and Materials**

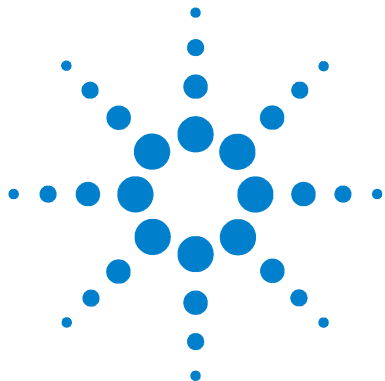

## 6 Introduction to the Quaternary Pump

Introduction to the Quaternary Pump	204
Overview	205
Electrical Connections	210
Instrument Layout	212
Early Maintenance Feedback (EMF)	213
The Electronics	215
Firmware Description	220
Optional Interface Boards	222
Agilent 1100 Series Interfaces	225
Setting the 8-bit Configuration Switch	230
The Main Power Supply Assembly	235



## Introduction to the Quaternary Pump

The quaternary pump comprises a solvent cabinet, a vacuum degasser and a four-channel gradient pump. The four-channel gradient pump comprises a high-speed proportioning valve and a pump assembly. It provides gradient generation by low pressure mixing. Degassing is a must for a low-pressure gradient system therefore the Agilent 1100 Series vacuum degasser is part of the quaternary pump system. A solvent cabinet provides enough space for four one-liter bottles. A continuous seal wash (optional) is available when the quaternary pump is used with concentrated buffer solutions.

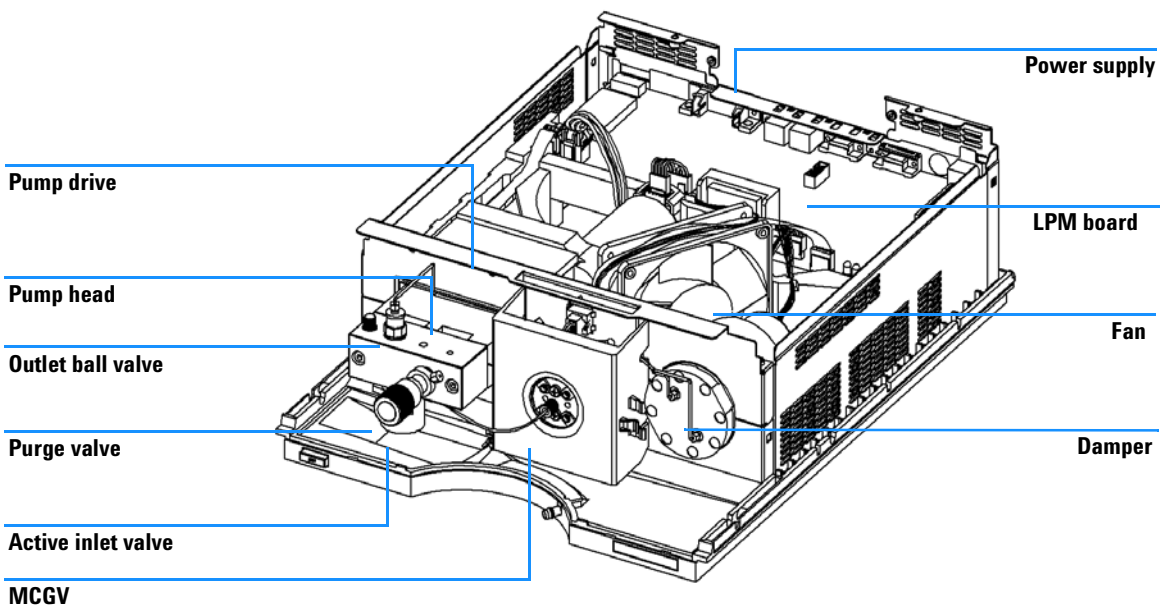

**Figure 41** Overview of the Quaternary Pump

## Overview

The quaternary pump is based on a two-channel, dual plunger in-series design which comprises all essential functions that a solvent delivery system has to fulfill. Metering of solvent and delivery to the high-pressure side are performed by one pump assembly which can generate pressure up to 400 bar.

Degassing of the solvents is done in a vacuum degasser and solvent compositions are generated on the low-pressure side by a high-speed proportioning valve.

The pump assembly includes a pump head with an active inlet valve which has a replaceable cartridge, and an outlet valve. A damping unit is connected between the two plunger chambers. A purge valve including a PTFE frit is fitted at the pump outlet for convenient priming of the pump head.

A continuous seal wash (optional) is available when the quaternary pump is used with concentrated buffer solutions.

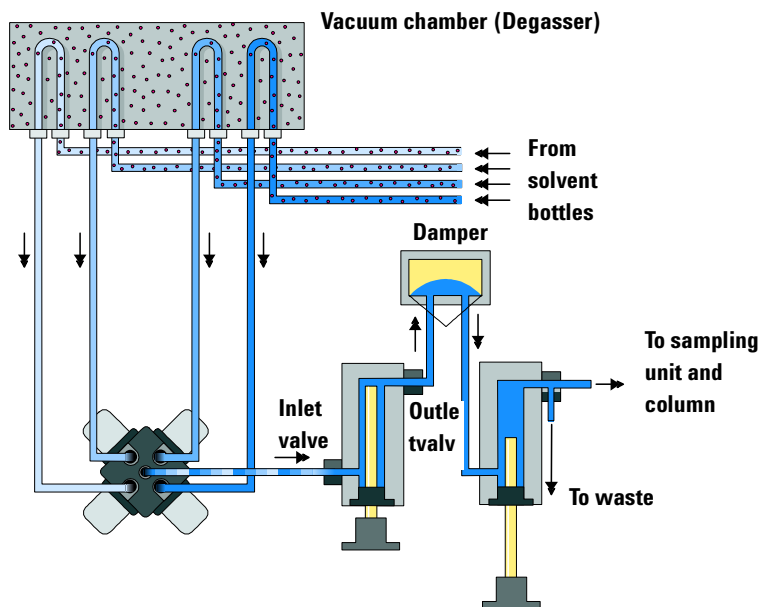

**Figure 42** Hydraulic Path of the Quaternary Pump

## How does the Pump Work?

The liquid runs from the solvent reservoir through the degasser to the MCGV and from there to the active inlet valve. The pump assembly comprises two substantially identical plunger/chamber units. Both plunger/chamber units comprise a ball-screw drive and a pump head with one sapphire plunger for reciprocating movement in it.

A servo-controlled variable reluctance motor drives the two ball-screw drives in opposite directions. The gears for the ball-screw drives have different circumferences (ratio 2:1) allowing the first plunger to move at twice the speed of the second plunger. The solvent enters the pump head close to the bottom limit and leaves it at its top. The outer diameter of the plunger is smaller than the inner diameter of the pump head chamber allowing the solvent to fill the gap in between. The first plunger has a stroke volume in the range of 20–100  $\mu\text{l}$  depending on the flow rate. The microprocessor controls all flow rates in a range of 1  $\mu\text{l}$ –10 ml/min. The inlet of the first plunger/chamber unit is connected to the active inlet valve which is processor-controlled opened or closed allowing solvent to be drawn into the first plunger pump unit.

The outlet of the first plunger/chamber unit is connected through the outlet ball valve and the damping unit to the inlet of the second plunger/chamber unit. The outlet of the purge valve assembly is then connected to the following chromatographic system.

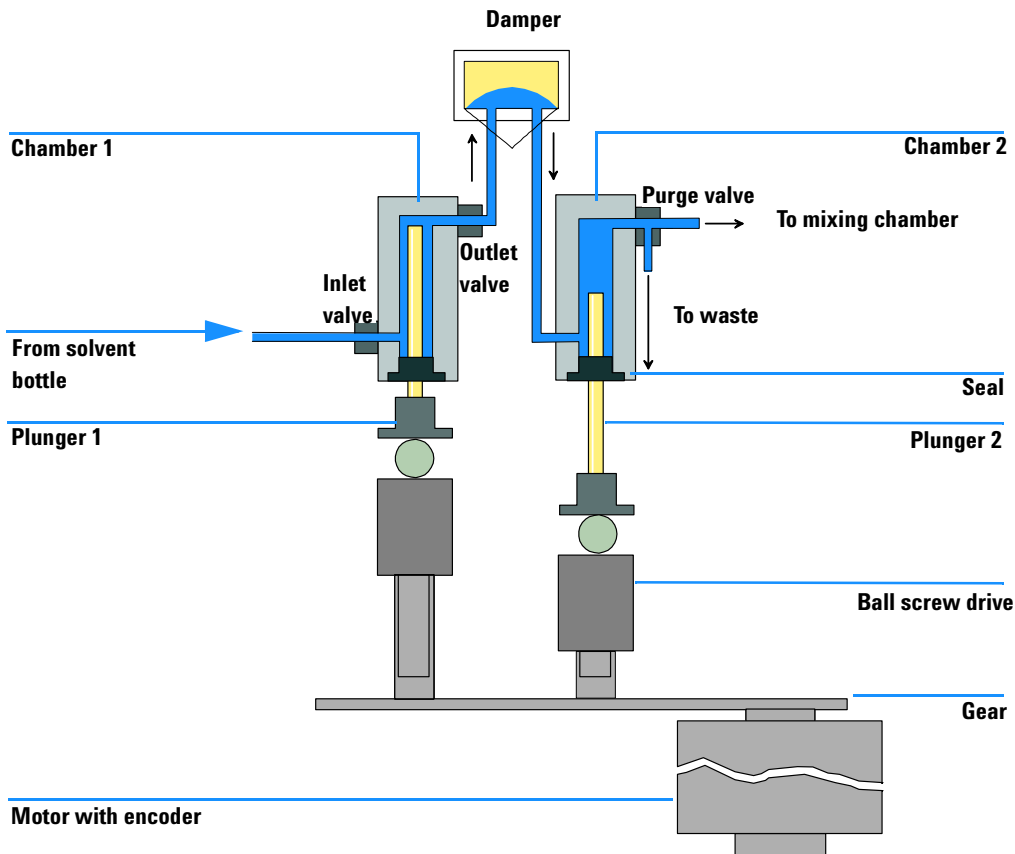

**Figure 43** Principle of the Quaternary Pump

When turned on, the quaternary pump runs through an initialization procedure to determine the upper dead center of the first plunger. The first plunger moves slowly upwards into the mechanical stop of chamber and from there it moves back a predetermined path length. The controller stores this plunger position in memory. After this initialization the quaternary pump starts operation with the set parameters. The active inlet valve is opened and the down-moving plunger draws solvent into the first chamber. At the same time the second plunger is moving upwards delivering into the system. After a controller-defined stroke length (depending on the flow rate) the drive motor is stopped and the active inlet valve is closed. The motor direction is reversed and moves the first plunger up until it reaches the stored upper limit and at

the same time moving the second plunger downwards. Then the sequence starts again moving the plungers up and down between the two limits. During the up movement of the first plunger the solvent in the chamber is pressed through the outlet ball valve into the second chamber. The second plunger draws in half of the volume displaced by the first plunger and the remaining half volume is directly delivered into the system. During the drawing stroke of the first plunger, the second plunger delivers the drawn volume into the system.

For solvent compositions from the solvent bottles A, B, C, D the controller divides the length of the intake stroke in certain fractions in which the gradient valve connects the specified solvent channel to the pump input.

**Table 46** Quaternary Pump Details

Delay volume	800–1100 µl, dependent on back pressure
Materials in contact with mobile phase	
MCGV	PTFE
Pump head	SST, gold, sapphire, ceramic
Active inlet valve	SST, gold, sapphire, ruby, ceramic, PTFE
Outlet valve	SST, gold, sapphire, ruby
Adapter	SST, gold
Purge valve	SST, gold, PTFE, ceramic, PEEK
Damping unit	Gold, SST

For quaternary pump specifications, see [Chapter 8](#), “Specifications.”

## How Does Compressibility Compensation Work?

The compressibility of the solvents in use will affect retention-time stability when the back pressure in the system changes (for example, ageing of column). In order to minimize this effect, the pump provides a compressibility compensation feature which optimizes the flow stability according to the solvent type. The compressibility compensation is set to a default value and can be changed through the user interface.



Without a compressibility compensation the following will happen during a stroke of the first plunger. The pressure in the plunger chamber increases and the volume in the chamber will be compressed depending on backpressure and solvent type. The volume displaced into the system will be reduced by the compressed volume.

With a compressibility value set the processor calculates a compensation volume, that is depending on the backpressure in the system and the selected compressibility. This compensation volume will be added to the normal stroke volume and compensates the previous described *loss* of volume during the delivery stroke of the first plunger.

## How Does Variable Stroke Volume Work?

Due to the compression of the pump-chamber volume each plunger stroke of the pump will generate a small pressure pulsation, influencing the flow ripple of the pump. The amplitude of the pressure pulsation is mainly dependent on the stroke volume and the compressibility compensation for the solvent in use. Small stroke volumes will generate pressure pulsations of smaller amplitude than higher stroke volumes at same flow rates. In addition the frequency of the pressure pulsations will be higher. This will decrease the influence of flow pulsations on quantitative results.

In gradient mode smaller stroke volumes resulting in less flow ripple will improve composition ripple.

The quaternary pump uses a processor-controlled spindle system to drive its plungers. The normal stroke volume is optimized for the selected flow rate. Small flow rates use a small stroke volume while higher flow rates use a higher stroke volume.

The stroke volume for the pump is set to AUTO mode. This means that the stroke is optimized for the flow rate in use. A change to larger stroke volumes is possible but not recommended.

## Electrical Connections

- The GPIB connector is used to connect the pump with a computer. The address and control switch module next to the GPIB connector determines the GPIB address of your pump. The switches are preset to a default address ([Table 49](#) on page 225 or [Table 53](#) on page 230). This address is recognized at powercycling the module.
- The CAN bus is a serial bus with high speed data transfer. The two connectors for the CAN bus are used for internal Agilent 1100 Series module data transfer and synchronization.
- One analog output provides a pressure signal for integrators or data handling systems.
- The interface board slot is used for external contacts and BCD bottle number output or LAN connections.
- The REMOTE connector may be used in combination with other analytical instruments from Agilent Technologies if you want to use features such as start, stop, common shut down, prepare, and so on.
- With the appropriate software, the RS-232C connector may be used to control the module from a computer through a RS-232C connection. This connector is activated and can be configured with the configuration switch next to the GPIB connector (see "[Communication Settings for RS-232C Communication](#)" on page 232). See your software documentation for further information.
- The power input socket accepts a line voltage of 100–120 or 220–240 volts AC  $\pm$  10% with a line frequency of 50 or 60 Hz. Maximum power consumption is 220 VA. There is no voltage selector on your module because the power supply has wide-ranging capability. There are no externally accessible fuses, because automatic electronic fuses are implemented in the power supply. The security lever at the power input socket prevents the module cover from being taken off when line power is still connected.

### WARNING

**Never use cables other than the ones supplied by Agilent Technologies to ensure proper functionality and compliance with safety or EMC regulations.**

---

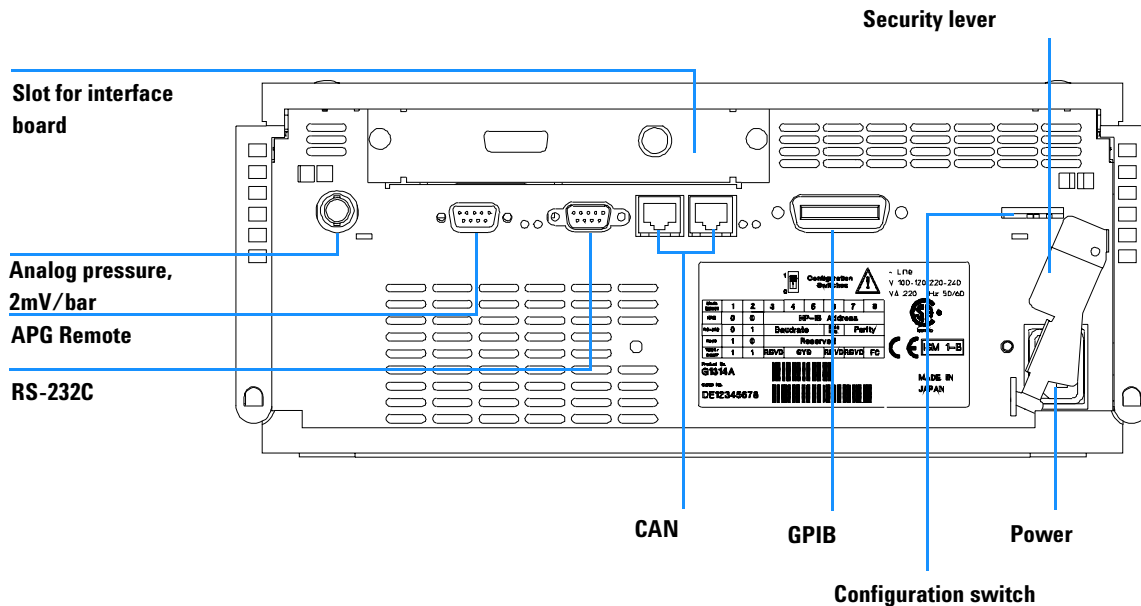

Figure 44 Electrical Connections

**WARNING**

To disconnect the quaternary pump from line, unplug the power cord. The power supply still uses some power, even if the power switch on the front panel is turned off.

## Instrument Layout

The industrial design of the module incorporates several innovative features. It uses Agilent's E-PAC concept for the packaging of electronics and mechanical assemblies. This concept is based upon the use of expanded polypropylene (EPP) layers foam plastic spacers in which the mechanical and electronic boards components of the module are placed. This pack is then housed in a metal inner cabinet which is enclosed by a plastic external cabinet. The advantages of this packaging technology are:

- virtual elimination of fixing screws, bolts or ties, reducing the number of components and increasing the speed of assembly/disassembly,
- the plastic layers have air channels molded into them so that cooling air can be guided exactly to the required locations,
- the plastic layers help cushion the electronic and mechanical parts from physical shock, and
- the metal inner cabinet shields the internal electronics from electromagnetic interference and also helps to reduce or eliminate radio frequency emissions from the instrument itself.

## Early Maintenance Feedback (EMF)

Maintenance requires the exchange of components in the flow path which are subject to mechanical wear or stress. Ideally, the frequency at which components are exchanged should be based on the intensity of usage of the instrument and the analytical conditions, and not on a predefined time interval. The early maintenance feedback (EMF) feature monitors the usage of specific components in the instrument, and provides feedback when the user-settable limits have been exceeded. The visual feedback in the user interface provides an indication that maintenance procedures should be scheduled.

### EMF Counters

The quaternary pump provides a series of EMF counters for the pump head. Each counter increments with pump use, and can be assigned a maximum limit which provides visual feedback in the user interface when the limit is exceeded. Each counter can be reset to zero after maintenance has been done. The quaternary pump provides the following EMF counters:

- Pump Liquimeter
- Pump seal wear

#### Pump Liquimeter

The pump liquimeter displays the total volume of solvent pumped by the pump head since the last reset of the counters. The pump liquimeter can be assigned an EMF (maximum) limit. When the limit is exceeded, the EMF flag in the user interface is displayed.

#### Seal Wear Counters

The seal wear counters display a value derived from pressure and flow (both contribute to seal wear). The values increment with pump usage until the counters are reset after seal maintenance. Both seal wear counters can be assigned an EMF (maximum) limit. When the limit is exceeded, the EMF flag in the user interface is displayed.

## **Using the EMF Counters**

The user-settable EMF limits for the EMF counters enable the early maintenance feedback to be adapted to specific user requirements. The wear of pump components is dependent on the analytical conditions, therefore, the definition of the maximum limits need to be determined based on the specific operating conditions of the instrument.

### **Setting the EMF Limits**

The setting of the EMF limits must be optimized over one or two maintenance cycles. Initially, no EMF limit should be set. When performance indicates maintenance is necessary, take note of the values displayed by pump liquimeter and seal wear counters. Enter these values (or values slightly less than the displayed values) as EMF limits, and then reset the EMF counters to zero. The next time the EMF counters exceed the new EMF limits, the EMF flag will be displayed, providing a reminder that maintenance needs to be scheduled.

## The Electronics

The electronics are comprised of four main components:

- **The low pressure pump main board (LPM)**, see [page 216](#).
- **Power supply**, see [page 235](#).

Optional:

- **Interface board (BCD/external contacts)**, see [page 222](#).
- **Interface board (LAN)**, see [page 223](#).

## The Low-Pressure Pump Main Board (LPM)

The board controls all information and activities of all assemblies within the quaternary pump. The operator enters parameters, changes modes and controls the quaternary pump through interfaces (CAN, GPIB or RS-232C) connected to the user-interfaces. [Figure 46](#) and [Figure 47](#) show the block diagrams of this board.

### **ASIC — Application-Specific Integrated Circuit**

The application-specific integrated circuit (ASIC) includes all digital logic for the core processor functions and also for module-specific functions.

### **Motor Drive**

The drive comprises motor control, motor amplifier (drive) and current control.

### **Active Inlet Valve Drive**

The drive comprises two amplifiers for the two contacts of valve solenoid.

### **Gradient Valve Drive**

The drive consists of the amplifiers for the four solenoids of the gradient valve.

### **Pressure Converter**

This block comprises a filter and amplifier for the pressure-sensor-signal, a multiplexer, an A/D converter and an offset correction for the analog pressure output signal. The output voltage is 2 mV/bar.

### **Leak Converter**

This block comprises a PTC for the leak identification and a NTC for the ambient temperature measurement. This assures that temperature changes are not identified as leak. A leak would cool down the PTC and its change in resistance results in a leak signal.



## Fan Drive

The fan speed is controlled by the main processor depending on the internal heat distribution in the quaternary pump. The fan provides a PWM signal which is proportional to its speed. This fan status signal is used for diagnostics.

## Electronic Fuses

The valve circuits are electronically fused on the board. Any error on the board or shortages of the valves will activate the electronic fuses that will switch off the supply voltage. This prevents the damage to components.

## Onboard Battery

An onboard lithium battery buffers the electronic memories when the quaternary pump is turned off.

For safety information on Lithium batteries see "[Lithium Batteries Information](#)" on page 267.

## Interfaces

The quaternary pump provides the following interfaces:

- two CAN connectors as interface to other Agilent 1100 Series modules
- one GPIB connector as interface to the ChemStation
- one RS-232C for as interface to a computer
- one REMOTE connector as interface to other Agilent products
- one Analog Output for pressure signal output
- one optional interface board

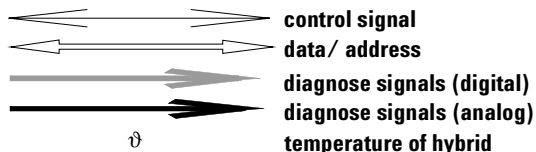

**Figure 45** Block Diagram Signal Explanations



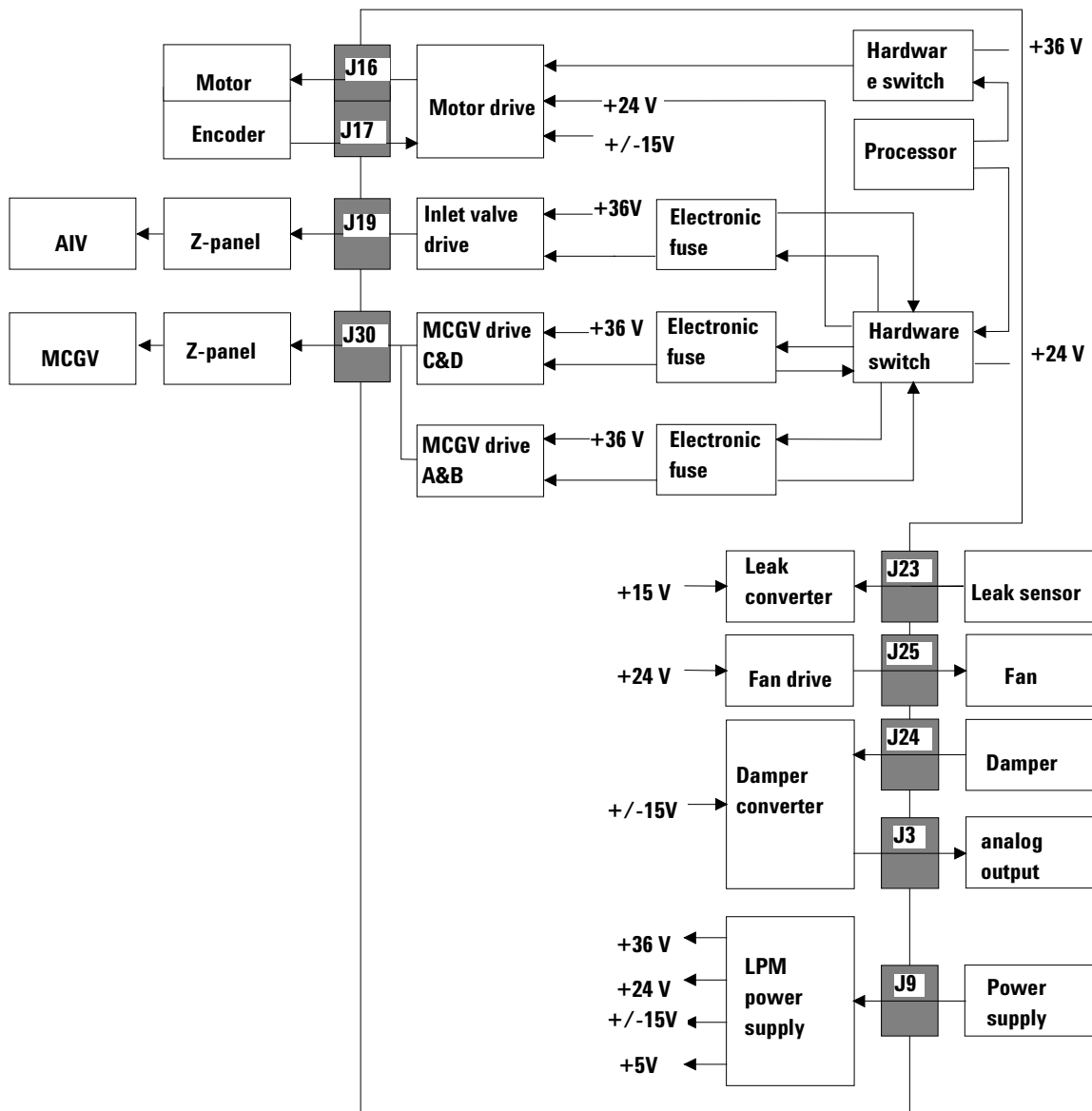

Figure 47 Interconnection Diagram Low Pressure Main Board (LPM)

## Firmware Description

The firmware of the instrument consists of two independent sections:

- a non-instrument specific section, called 'resident system',
- an instrument specific section, called 'main system'.

### Resident System

This resident section of the firmware is identical for all Agilent 1100 series modules. Its properties are:

- the complete communication capabilities (GPIB, CAN, LAN and RS-232C),
- memory management,
- ability to update the firmware of the 'main system'.

### Main System

Its properties are:

- the complete communication capabilities (GPIB, CAN, LAN and RS-232C),
- memory management,
- ability to update the firmware of the 'resident system'.

In addition the main system comprises the instrument functions that are divided into common functions like

- run synchronisation via APG remote
- error handling,
- diagnostic functions and so on,

or module specific functions like

- internal events such as motor control, flow rates and so on,
- calculation of compensation values for variable strokes and pressures.

## Firmware Updates

Firmware updates can be done using your user interface:

- handheld control module with files from a PC-card or
- Agilent ChemStation with files from floppy disk

The file naming conventions are:

xxxx-vvv.DLB, where

xxxx is the product number, e.g. 1311 for the G1311A Quaternary Pump), and vvv is the revision number, for example 200 is revision 2.00.

For instructions refer to your user interface.

**NOTE**

Update of main system can be done in the resident system only.

Update of the resident system can be done in the main system only.

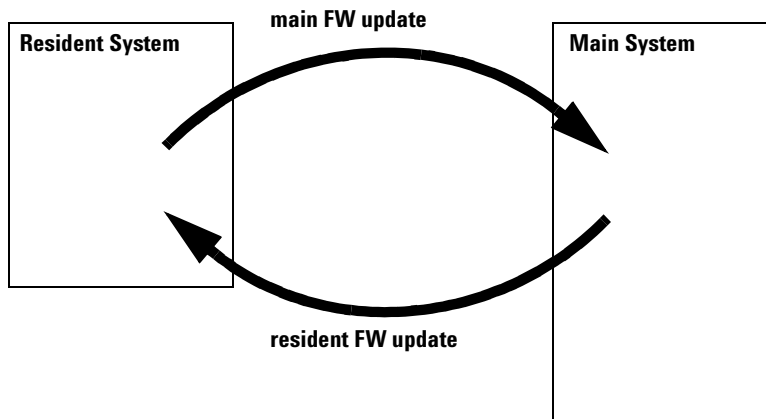

**Figure 48** Firmware Update Mechanism

## Optional Interface Boards

The Agilent 1100 Series modules have one optional board slot that allows to add an interface board to the modules.

**Table 47** Optional Interface Boards

Description	Part Number
BCD Board	G1351-68701
Fuse 250 mA (four are on the board)	2110-0004
LAN Board (see next page for details)	

### BCD Board

The BCD board provides a BCD output for the bottle number of the Agilent 1100 Series autosampler and four external contacts. The external contact closure contacts are relay contacts. The maximum settings are: 30 V (AC/DC); 250 mA (fused). There are general purpose cables available to connect the BCD output, see "[BCD Cables](#)" on page 194 and the external outputs, see "[External Contact Cable](#)" on page 199 to external devices.

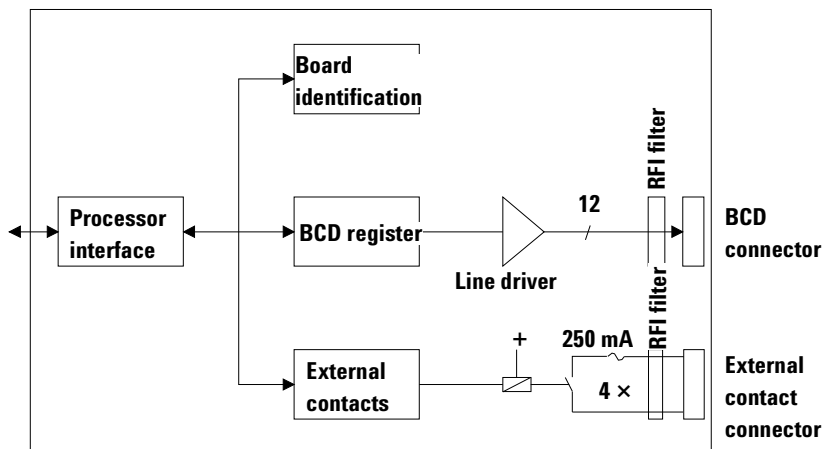

**Figure 49** Block Diagram BCD Board

## LAN Board

The HP LAN board is actually an HP JetDirect card, which is a network interface card used in HP printers.

### NOTE

One board is required per Agilent 1100 stack. If the Agilent 1100 stack has a DAD, then the DAD **MUST** be the module used for LAN board installation. If no DAD is present a pump should be used for the LAN board installation.

### NOTE

The LAN board can only be used together with:

A DAD/MWD/VWD/Pump/ALS with main board version G13XX-66520 and greater. An FLD/RID with main board version G13XX-66500 and greater.

a DOS-ChemStation software revision A.06.01 or above.

The following boards can be used with the Agilent 1100 modules.

**Table 48** LAN Boards

Agilent Order Number	Supported networks
J4106A	Ethernet/802.3, RJ-45 (10Base-T)
J4105A	Token Ring/802.5, DB9, RJ-45 (10Base-T)
J4100A	Fast Ethernet, Ethernet/802.3, RJ-45 (10/100Base-TX) + BNC (10Base2)

**NOTE**

Minimum firmware of the LAN boards is A.05.05.

### Recommended Cables

For point to point connection (not using a network hub) use a twisted pair cross over LAN cable (P/N 5183-4649, 10 feet long).

For standard network connections using a hub use category 5 UTP cables, (P/N G1530-61480, 8 m long).



## Agilent 1100 Series Interfaces

The Agilent 1100 Series modules provide the following interfaces:

**Table 49** Agilent 1100 Series Interfaces

Interface Type	Pumps	Autosampler	DA Detector MW Detector FL Detector	VW Detector RI Detector	Thermostatted Column Compartment	Vacuum Degasser
CAN	Yes	Yes	Yes	Yes	Yes	No
GPIB	Yes	Yes	Yes	Yes	Yes	No
RS-232C	Yes	Yes	Yes	Yes	Yes	No
APG Remote	Yes	Yes	Yes	Yes	Yes	Yes
Analog	Yes	No	2 ×	1 ×	No	Yes*
Interface board	Yes	Yes	Yes	Yes	No	No

\* The vacuum degasser will have a special connector for specific use. For details, see the degasser manual.

- The CAN connectors serve as the interface between the Agilent 1100 Series modules themselves,
- the GPIB connector serves as the interface between an Agilent 1100 module and the Agilent ChemStation,
- RS-232C provides an interface to a computer,
- the APG remote connector serves as the interface between the Agilent 1100 and other Agilent (APG remote compatible) products,
- the analog output connector(s) provide an analog signal output,
- the interface board slot (not common to all modules) provides specific interfacing needs (external contacts, BCD, LAN and so on).

For identification and location of the connectors see [Figure 3](#) on page 23.

**WARNING**

Never use cables other than the ones supplied by Agilent Technologies to ensure proper functionality and compliance with safety or EMC regulations, see "[Cable Overview](#)" on page 183.

## Analog Signal Output

The analog signal output can be distributed to a recording device. For details refer to the description of the main board of the module.

## GPIO Interface

The GPIO connector is used to connect the module with a computer. The address and control switches next to the GPIO connector determine the GPIO address of your module. The switches are preset to a default address and recognized by the operating software from Agilent Technologies.

**Table 50** Default GPIO Addresses

G131x Pumps	22	DAD (HP 1040)	15
G1313 Autosampler	28	FLD (HP 1046)	12
G1327 Thermostatted Sampler	28	ECD (Agilent 1049)	11
G1316 Column Compartment	27		
G1314 VWD	24	Pumps (HP 1050)	16
G1315/G1365 DAD/MWD	26	Autosampler (HP 1050)	18
G1321 FLD	23	VWD (HP 1050)	10
G1362 RID	29	DAD (HP 1050)	17
		MWD (HP 1050)	17
Agilent 8453A	25		

## CAN Interface

The CAN is an inter module communication interface. It is a 2 wire serial bus system supporting high speed data communication and real-time requirements.

## APG Remote Interface

The APG Remote connector may be used in combination with other analytical instruments from Agilent Technologies if you want to use features as common shut down, prepare, and so on.

Remote control allows easy connection between single instruments or systems to ensure coordinated analysis with simple coupling requirements.

The subminiature D connector is used. The quaternary pump provides one remote connector which is inputs/outputs (wired-or technique).

To provide maximum safety within a distributed analysis system, one line is dedicated to SHUT DOWN the system's critical parts in case any module detects a serious problem. To detect whether all participating modules are switched on or properly powered, one line is defined to summarize the POWER ON state of all connected modules. Control of analysis is maintained by signal readiness READY for next analysis, followed by START of run and optional STOP of run triggered on the respective lines. In addition PREPARE and START REQUEST may be issued. The signal level are defined as:

- standard TTL levels (low = 0.0 - 0.8 V, high = +2.0 - 5.0 V)
- fan-out is 10,
- input load is 1.7 kOhm against + 5 V, and
- output are open collector type, inputs/outputs (wired-or technique).

**Table 51** APG Remote Signal Distribution

Pin	Signal	Description
1	DGND	Digital ground
2	PREPARE	(L) Request to prepare for analysis (for example, detector lamp on). Receiver is any module performing preanalysis activities.

**Table 51** APG Remote Signal Distribution (continued)

Pin	Signal	Description
3	START	(L) Request to start run / timetable. Receiver is any module performing run-time controlled activities.
4	SHUT DOWN	(L) System has serious problem (for example, leak: stops pump). Receiver is any module that needs to be shutdown to avoid a safety risk.
5		Not used
6	POWER ON	(H) All modules connected to system are switched on. Receiver is any module relying on operation of others.
7	READY	(H) System is ready for next analysis. Receiver is any sequence controller.
8	STOP	(L) Request to reach system ready state as soon as possible (for example, stop run, abort or finish and stop injection). Receiver is any module performing run-time controlled activities.
9	START REQUEST	(L) Request to start injection cycle. Receiver is the autosampler.

## RS-232C

The RS-232C connector is used to control the instrument from a computer through RS-232C connection, using the appropriate software. This connector can be configured with the configuration switch module next to the GPIB connector. The RS-232C is designed as DCE (data communication equipment) with a 9-pin male SUB-D type connector. The pins are defined as:

**Table 52** RS-232C Connection Table

Pin	Direction	Function
1	In	DCD
2	In	RxD
3	Out	TxD
4	Out	DTR
5		Ground

**Table 52** RS-232C Connection Table (continued)

Pin	Direction	Function
6	In	DSR
7	Out	RTS
8	In	CTS
9	In	RI

## Instrument

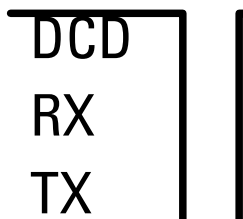
**Figure 50** RS-232 Cable

## Setting the 8-bit Configuration Switch

The 8-bit configuration switch is located next to the GPIB connector. Switch settings provide configuration parameters for GPIB address, serial communication protocol and instrument specific initialization procedures.

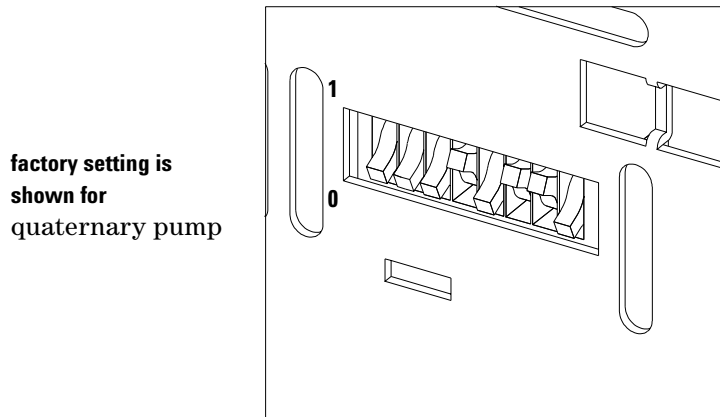

**Figure 51** 8-bit Configuration Switch

**Table 53** 8-bit Configuration Switch

Mode Select	1	2	3	4	5	6	7	8
GPIB	0	0	GPIB Address					
RS-232C	0	1	Baudrate			Data Bits	Parity	
Reserved	1	0	Reserved					
TEST/BOOT	1	1	RSVD	SYS		RSVD	RSVD	FC

Switches 1 and 2 define which set of parameters (for example, for GPIB, RS-232C, and so on) will be changed. Once the change has been completed, the instrument must be powered up again in order to store the values in the non-volatile memory.

In the non-volatile memory the parameters are kept, regardless of whether you turn the instrument off and on again. They will be kept until the same set of parameters is subsequently changed and power is reset. All other previously stored configuration settings will still remain in the non-volatile memory.

In this way you can store more than one set of parameters using the same 8-bit configuration switch twice,, for example, for both GPIB and RS-232C.

## GPIB Default Addresses

If you just want to change the GPIB address and need a detailed procedure, refer to the *Installing Your ChemStation System* handbook. Default GPIB address is set to the following addresses::

**Table 54** Default Addresses for Agilent Series 1100 Modules

Module	Address	Binary Address
Pump	22	0 0 0 1 0 1 1 0
FLD	23	0 0 0 1 0 1 1 1
VWD	24	0 0 0 1 1 0 0 0
Agilent 8453A	25	0 0 0 1 1 1 0 1
DAD/MWD	26	0 0 0 1 1 0 1 0
Column compartment	27	0 0 0 1 1 0 1 1
Autosampler	28	0 0 0 1 1 1 0 0
RID	29	0 0 0 1 1 1 0 1

where 0 means that the switch is down and 1 means that the switch is up.

## Communication Settings for RS-232C Communication

The communication protocol used in the instrument supports only hardware handshake (CTS/RTR).

Switches 1 in down and 2 in up position define that the RS-232C parameters will be changed. Once the change has been completed, the instrument must be powered up again in order to store the values in the non-volatile memory.

**Table 55** Communication Settings for RS-232C Communication

Mode Select	1	2	3	4	5	6	7	8
RS-232	0	1	Baudrate			Data Bits	Parity	

Use the following tables for selecting the setting which you want to use for RS-232C communication. The number 0 means that the switch is down and 1 means that the switch is up.

**Table 56** Baudrate Settings

Switches			Baud Rate	Switches			Baud Rate
3	4	5		3	4	5	
0	0	0	9600 (default)	1	0	0	9600
0	0	1	1200	1	0	1	14400
0	1	0	2400	1	1	0	19200
0	1	1	4800	1	1	1	38400

**Table 57** Data Bit Settings

Switch 6	Data Word Size
0	7 Bit Communication
1	8 Bit Communication

One start bit and one stop bit are always used (not selectable).



Per default, the module will turn into 19200 baud, 8 data bit with no parity.

**Table 58** Parity Settings

Switches		Parity
7	8	
0	0	No Parity
0	1	Odd Parity
1	0	Even Parity

## Forced Cold-Start Settings

Switches 1 and 2 do not force storage of this set of parameters in non-volatile memory. Returning the switches 1 and 2 to other positions (other than being both up) will allow for normal operation.

### CAUTION

A forced cold start erases all methods and data stored in non-volatile memory. Exceptions are diagnose and repair logbooks will not be erased.

If you use the following switch settings and power the instrument up again, a forced cold start has been completed.

**Table 59** Forced Cold Start Settings

Mode Select	1	2	3	4	5	6	7	8
TEST/BOOT	1	1	0	0	0	0	0	1

To return to normal operation, set switches back to your GPIB or RS 232C configuration settings.

## Stay Resident Settings

Firmware update procedures may require this mode in case of firmware loading errors.

Switches 1 and 2 do not force storage of this set of parameters in non-volatile memory. Returning the switches 1 and 2 to other positions (other than being both up) will allow for normal operation.

If you use the following switch settings and power the instrument up again, the instrument firmware stays in the resident part, that is, it is not operable as a quaternary pump. It only uses basic functions of the operating system, for example, for communication, and so on.

**Table 60** Stay Resident Settings

Mode Select	1	2	3	4	5	6	7	8
TEST/BOOT	1	1	0	0	1	0	0	0

To return to normal operation, set switches back to your GPIB or RS 232C configuration settings.

## The Main Power Supply Assembly

The main power supply comprises a closed assembly (no component-level repair possibility).

The power supply provides all DC voltages used in the quaternary pump. The line voltage can vary in a range from 100 – 120 or 220 – 240 volts AC  $\pm$  10 % and needs no manual setting.

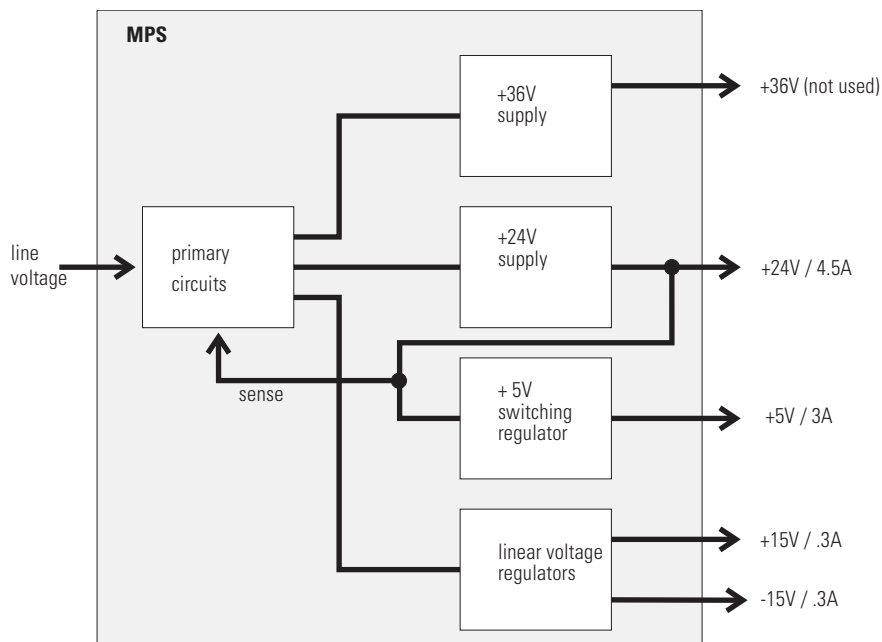

**Figure 52** Main Power Supply (MPS) Block Diagram

### WARNING

**To disconnect the instrument from line, unplug the power cord. The power supply still uses some power, even if the power switch on the front panel is turned off.**

No accessible hardware fuse is needed because the main power supply is safe against any short circuits or overload conditions on the output lines. When overload conditions occur, the power supply turns off all output voltages. Turning the line power off and on again resets the power supply to normal operation if the cause of the overload condition has been removed.

An over-temperature sensor in the main power supply is used to turn off output voltages if the temperature exceeds the acceptable limit (for example, if the cooling fan of the quaternary pump fails). To reset the main power supply to normal operating conditions, turn the quaternary pump off, wait until it is approximately at ambient temperature and turn the quaternary pump on again.

The following table gives the specifications of the main power supply.

**Table 61** Main Power Supply Specifications

Maximum power	130 W	Continuous output
Line Input	100 – 120 or 220 – 240 volts AC ± 10 %, line frequency of 50/60 Hz	Wide ranging
Output 1	+ 24 V / 4.5 A (maximum)	Total power consumption of +24V and
Output 2	+ 36 V / 2.5 A (maximum)	+36V must not exceed 107 W
Output 3	+ 5 V / 3 A	
Output 4	+ 15 V / 0.3 A	
Output 5	- 15 V / 0.3 A	

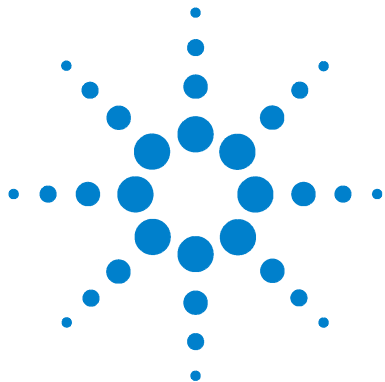

## 7 Control Module Screens for the Quaternary Pump

Major keys on the Agilent 1100 Control Module	238
Screens available from the Analysis screen	239
Screens available from the System screen	248
Screens available from the Records screen	250
Diagnostics and Tests	257



### Major keys on the Agilent 1100 Control Module

ESC	Return to previous screen and scroll through top layer views (Analysis, Settings)
m	Open context sensitive menus
i	Information/help
Enter	Store changed parameters or execute the choice from a pull-down menu
Done	(If available) Activate settings of current screen
On/Off	Switch on pump
Start	Start a run
Plot	View the pressure readings
Views	Change between view of analysis - status - system screens

#### NOTE

The screens shown on the next pages are based on the following firmware revisions:  
Control Module firmware revision B.01.01 (G1323B).  
LC Module firmware revision 3.8x

#### NOTE

In case the control module's display seems to be frozen (hang-up due to a communication problem on the CAN bus, unplug the control module from the LC module and reconnect.

## Screens available from the Analysis screen

### The Analysis screen

This is the wake-up screen, if the Agilent 1100 quaternary pump is the only configured Agilent 1100 module. It is used to enter the most common pump method parameters.

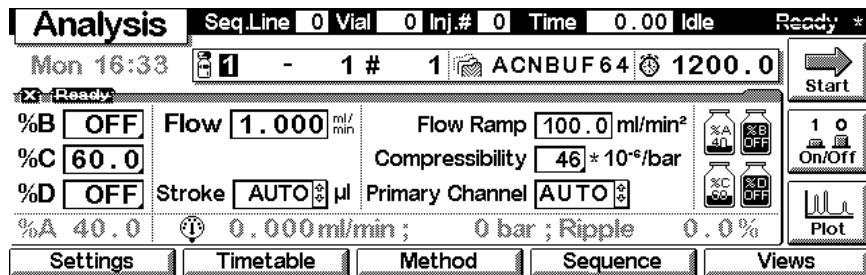

The **m**-key allows access to the context sensitive menu. **Date&Time** allows you to change time settings. **Print Screen** gives access to the print configuration screen. **About** tells you the current firmware revision and the serial# of your control module. **Setup view** leads you to add sections for additional Agilent 1100 modules. **Restart** re-boots the control module.

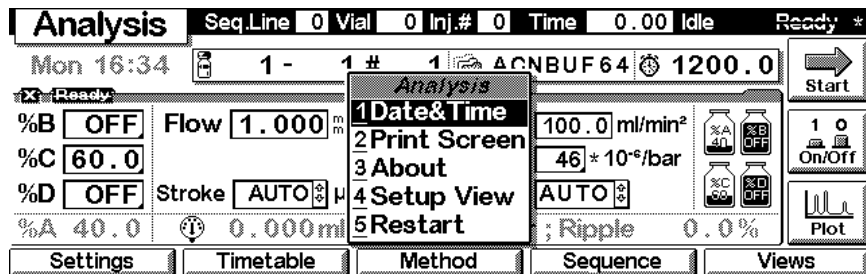

## 7 Control Module Screens for the Quaternary Pump

### Setup View

In the Setup view, modules can be added or removed to the view.

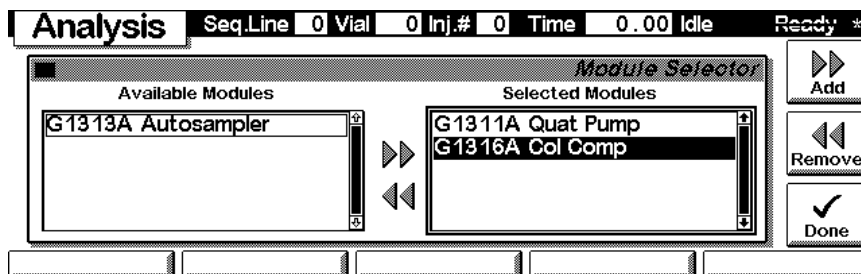

Here, e.g. the autosampler and thermostatted column compartment parameters are shown on the display as well. The number of parameters on the display is restricted as additional modules are added. A maximum of 4 modules is shown automatically. If more modules are connected to the system, you have to choose 4 of them in Setup view.

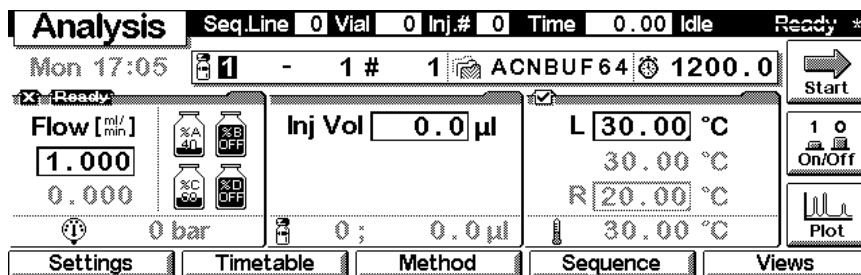



## Pump ON/OFF

From the Analysis screen use the F7 key to proceed to the turn on screen. Press F8 (**On**) once to turn on the pump. If more than one module is available, select the quaternary pump from the pop-up menu.

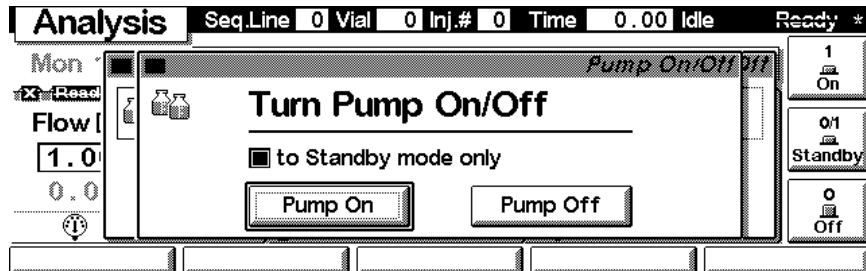
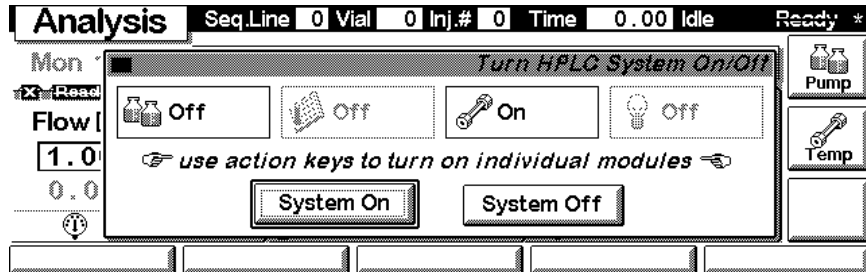

## Settings

With the **Settings** key you open a pull-down menu where you can select the quaternary pump module.

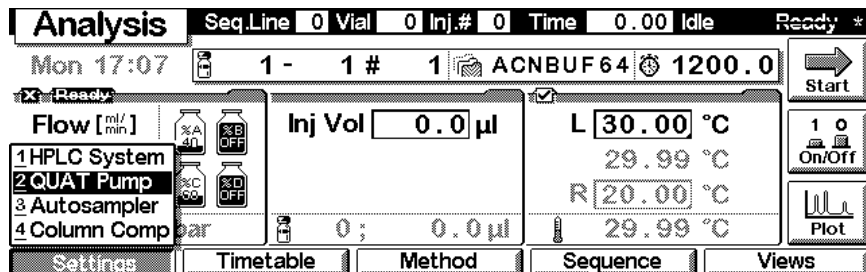

## 7 Control Module Screens for the Quaternary Pump

### Settings

Within the **Settings** you can change the pump parameters. You have access to a different set of parameters available through the F1-5 keys. F7 key resets the pump to default values. F8 opens a window to turn on the pump.

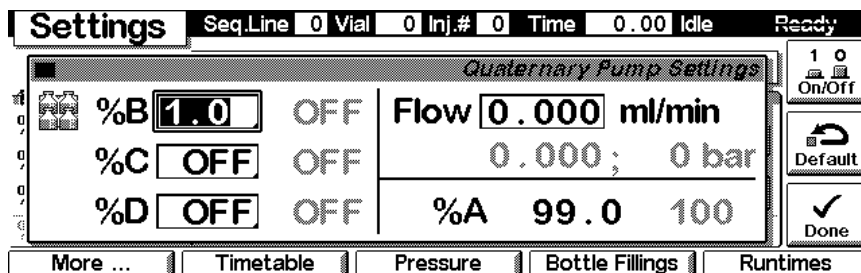

Use the **m**-key for the context sensitive menu. The **Status** command pulls up a monitor screen displaying signals and spectra as programmed. **Reset** will load the pump default parameters.

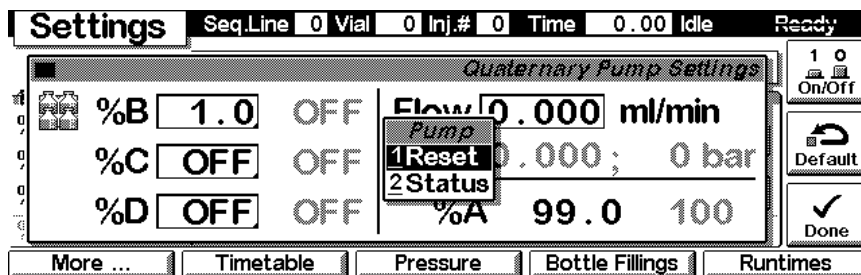

Use F1-key (**More**). You can enter special pump setpoints.

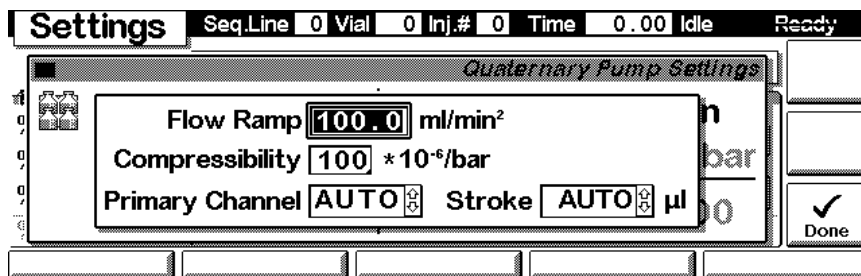



## 7 Control Module Screens for the Quaternary Pump

### Settings - Pressure

With the F3 key (**P**ressure) you can change the settings for the pressure limits.

**Settings** Seq.Line 0 Vial 0 Inj.# 0 Time 0.00 Idle Ready \*

Quaternary Pump Settings

Pressure Limits Lower 0 bar  
Upper 400 bar  
Actual Pressure 0 bar

Done

### Settings - Bottle Fillings

With the F4 key (**B**ottle Fillings) you can adjust the settings for the bottle fillings to their current state.

**Config** Pump [ ] Temp [x] Time 0.00 Idle Ready \*

Quaternary Pump Configuration

Actual [Liter]	A	B	C	D
	0.00	1.00	0.31	1.00
Total	1.00	1.00	1.00	1.00

Not-Ready below 0.10 Liter  Error if empty

Done

### Settings - Runtimes

With the F5 key (**R**untimes) you can change the stop time and the post-run time.

**Settings** Seq.Line 0 Vial 0 Inj.# 0 Time 0.00 Idle Ready \*

Quaternary Pump Settings

Stoptime 10.00 0.00 min  
Posttime OFF 0.00 min  
*overrides HPLC system runtime settings*

Done

### Analog -Status

Press F5 key (**Views**) and select **Status**.

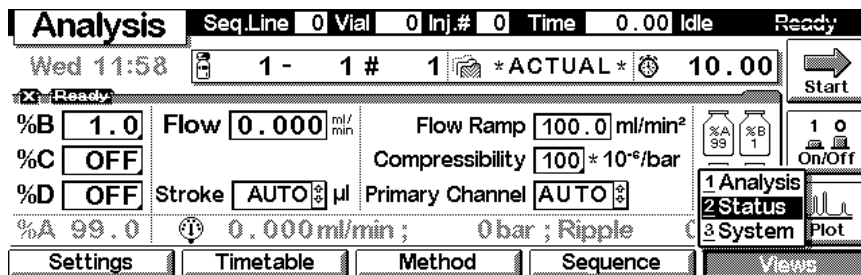

### Status

This is an example if an Agilent 1100 pump is configured standalone. Information on the actual flow rate, mobile phase composition, pressure and %-ripple, elapsed run time and the pressure plot are shown. Press key F8 (**Start**) to start a run, key F7 (**Rescale**) to maximize the signal.

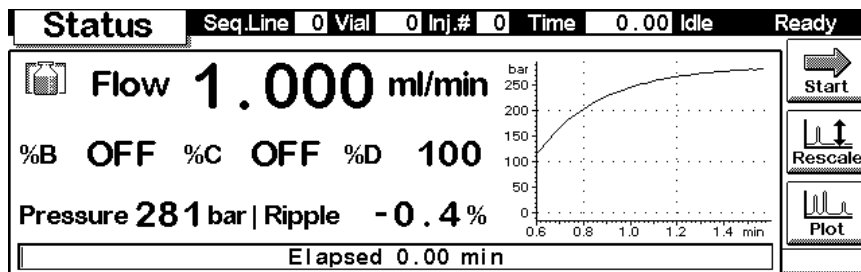

### Signal plot

Press F6 key (**Plot**) to enter the plot screen (available also from the **Analysis** and **System** screen). Here you can observe the online signal(s). To add additional online signals (maximum 3), press F6 key (**Select**). If more than one signal is configured, use the 1-2-3 numeric keys to switch between the signals.

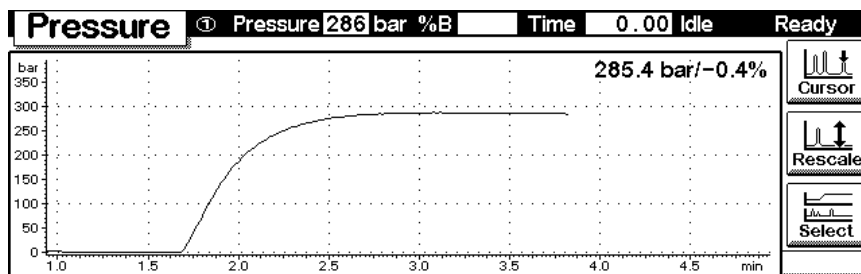

Press F6 key (**Select**). Here you can add additional online signals (maximum are 3). Additional signals could also be chromatograms or temperature signals from other modules. Use the Right/Left arrows to switch between Available and Selected Signals. Use the F8 key (**Move**) to enter available signals into the box for selected signals or vice versa. Press **Done** to activate the changed settings and to return to the **Plot** screen.

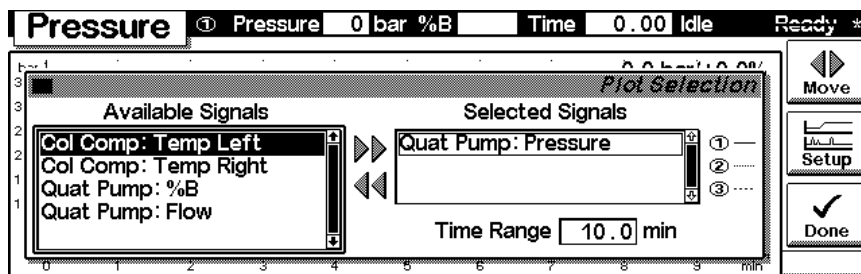

### Method screens

On the **Analysis** screen use the F3 key (**Method**) to view the parameters in a method and F8 key (**Save As**) to save the method in the module(s). The PC-Card key is only active when a PCMCIA card is inserted in the control module (has to be inserted even before powercycling).

Method				Seq.Line	0	Vial	0	Inj.#	0	Time	0.00	Idle	Ready *
Module	Setting	Value	ACNBUF64										
Quat Pump	Stoptime	1200.00 min											
Quat Pump	Posttime	OFF											
Quat Pump	Flow	1.000 ml/min											
Quat Pump	%B,%C,%D	OFF, 60.0 %, OFF											
Quat Pump	Lower Limit	0 bar											
Quat Pump	Upper Limit	400 bar											

Buttons: Save As, Default, Print

Module:

Use F2 key (**PC-Card**) to save a method on a PCMCIA card. Use the Right/Left arrows to switch between PC-Card and Instrument window. Use the UP/Down arrows to select the method. Use the F7/F8 keys (**Copy**) to enter available signals into the box for selected signals or vice versa.

Method				Seq.Line	0	Vial	0	Inj.#	0	Time	0.00	Idle	Ready *
Methods on PC-Card		Methods on Modules											
ALAIN	06/08/99 10:13	ACNBUF64	04/28/99 13:37										
ISO	06/08/99 10:14	*** end of method list ***											
*** end of method list ***													

Buttons: Copy, Copy, Delete

Initialize

## Screens available from the System screen

## System screen

Use the Esc key to receive **Views** on the F5 key. Choose **System** from the pull-down menu. This screen shows the last activities in the system.

The screenshot shows the 'System' screen with the following details:

- Header: **System** Pump  Temp  Time 0.00 Idle Ready \*
- Status: Mon 17:11 PUMP OFF EMF Start
- Activity Log:
 

Module	Message	Id	Date	Time
Col Comp	Calibration done	STATE	06/21	17:03:07
Col Comp	Column ID (right) not present	STATE	06/21	17:03:07
Autosampler	Initialization done	STATE	06/21	17:03:33
Col Comp	Column ID (left) not present	STATE	06/21	17:03:07
Quat Pump	Pump off	STATE	06/21	17:03:16
- Buttons: Control, Configure, Tests, Records, Views
- Icons: On/Off, Plot

## System - Control

Use the F1 key (**Control**) to select the quaternary pump. Here you receive information about the not-ready conditions if needed. F2 key (**Reset**) does a re-initialization of the pump.

The screenshot shows the 'System - Control' screen with the following details:

- Header: **System** Pump  Temp  Time 0.00 Idle Ready \*
- Status: Mon 17:12 PUMP OFF EMF Start
- Activity Log:
 

Module	Message	Id	Date	Time
Col Comp	Calibration done	STATE	06/21	17:03:07
1 HPLC System	Column ID (right) not present	STATE	06/21	17:03:07
2 QUAT Pump	Initialization done	STATE	06/21	17:03:33
3 Autosampler	Column ID (left) not present	STATE	06/21	17:03:07
4 Column Comp	Pump off	STATE	06/21	17:03:16
- Buttons: Control, Configure, Tests, Records, Views
- Icons: On/Off, Plot



## System - Configuration

On the **System** screen use the F2 key (**Configure**) to select the pump. Use the F1 key (**Interfaces**) to access the interface settings (if required).

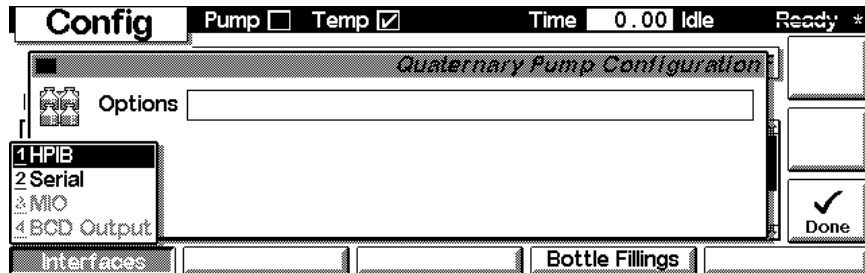

Press F4 (**Bottle fillings**) to adjust bottle fillings to the current state.

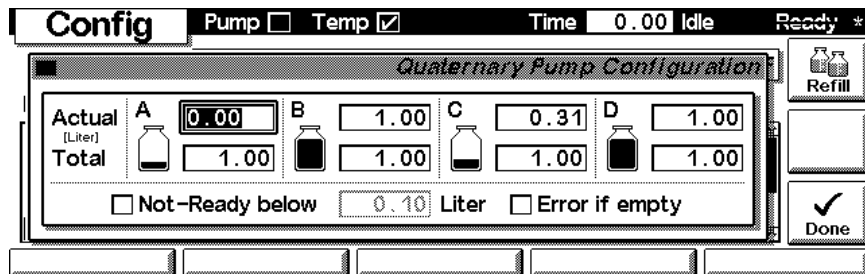

## Screens available from the Records screen

### Records screen

Use the Esc key to receive **Views** on the F5 key. Choose **System** from the pull-down menu. Use the F4 key (**Records**) to select the pump. Errors are reported either into the **System Log** (F2) or **Error Log** (F3).

Records						Pump <input type="checkbox"/>	Temp <input checked="" type="checkbox"/>	Time 0.00	Idle	Ready *
Module	Product#	Serial#	Version	On-Time	EMF					
Controller	G1323A*	DE00000044	A.02.04	0d 00:12h						
Quat Pump	G1311A	DE83101440	A.03.60	3d 05:46h						
Autosampler	G1313A	DE54901685	A.03.30	3d 05:46h						
Col Comp	G1316A*	DE53400113	A.03.60	3d 05:46h						

Buttons: EMF, System Log, Error Log, Maint Log, FW Update

Icons: Identify, Print

### System / Error Log

Use the F2 key (**System Log**) or F3 key (**Error Log**) to look for errors.

Records						Pump <input type="checkbox"/>	Temp <input checked="" type="checkbox"/>	Time 0.00	Idle	Ready *
Quaternary Pump System Logbook										
Message	Date	Time								
No analysis	99/06/21	17:03:16								
Pump off	99/06/21	17:03:16								
*** end of logbook ***										

Buttons: (empty)

Icon: Print

### Info Log

Use the **m**-key to receive a pop-up menu, Select **Info Log**. A list of the last events are listed. For troubleshooting reasons they can be printed or saved to a file on the PCMCIA card (using the **m**-key for the context sensitive menu).

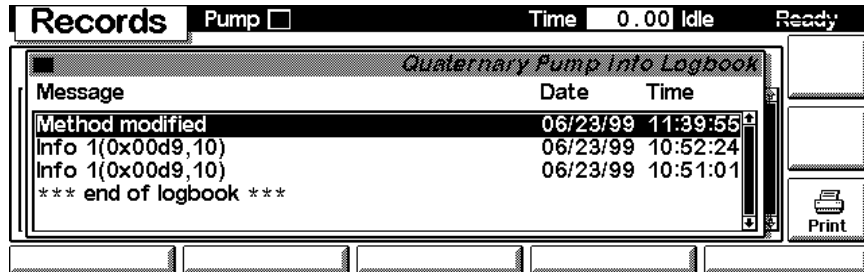

### EMF (Early Maintenance Feedback)

Use the F1 key (**EMF**) to set EMF parameters. Choose menu item 1 (**Setup limits**) to select the amount of pumped solvent or seal wear, when you want to receive a warning for exceeded limits. Press F7 (**Reset**) to reset the counters after exchanging parts that are subject to wear.

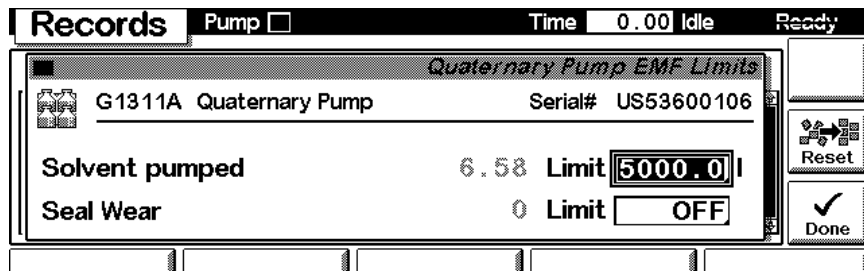

## 7 Control Module Screens for the Quaternary Pump

If a set limit has been exceeded, a message box will pop up. This will not stop a sequence or run (information only to plan maintenance activities). If you press **Reset**, the limits will be removed. **Ignore** will continue to keep the EMF flag set.

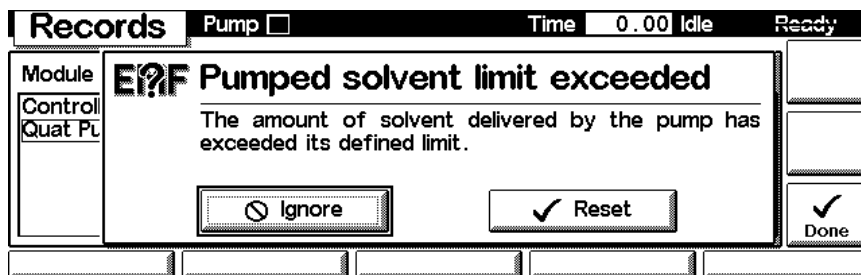

### Firmware Update

Use the Esc key to receive **Views** on the F5 key. Choose **System** from the pull-down menu. Use the F3 key (**Records**) to select the pump. Use the F5 key (**FW Update**) to enter the Update section. If you want to update the resident firmware (together with specific main firmware revisions), select the file from the PCMCIA card (RESnnnn.DLB) and press execute. If you want to update the main firmware, press F7 key (**Transfer**) to turn the module into the resident mode (LED on module should blink yellow).

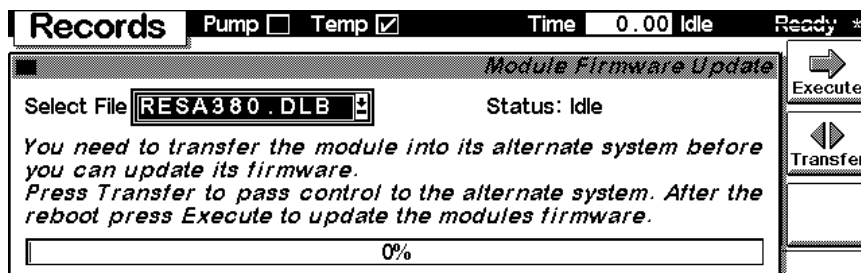

Use the **Esc** key to receive **Views** on the F5 key. Choose **System** from the pull-down menu. Use the F3 key (**Records**) to select the **Generic** module. In this screen the resident firmware revision is shown.

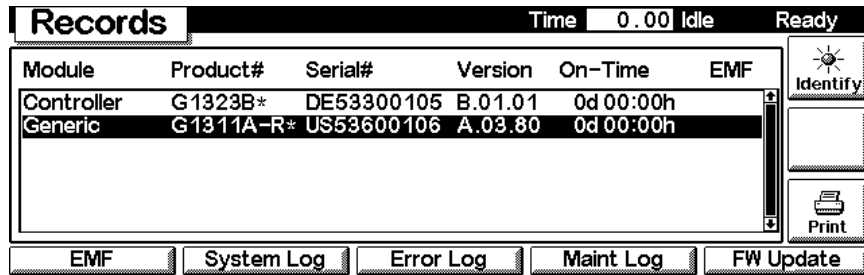

Use the F5 key (**FW Update**) to enter the Update section. Select the a file from the PCMCIA card (1311nnnn.DLB) and press execute. When the update has finished, press F7 key (**Transfer**) to return the module into the normal mode (LED on module should stay yellow).

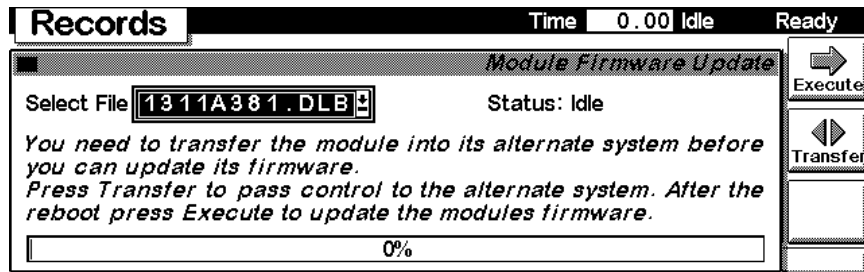

If you have not saved your methods, please do it before continuing. Otherwise they will be overwritten during the update process.

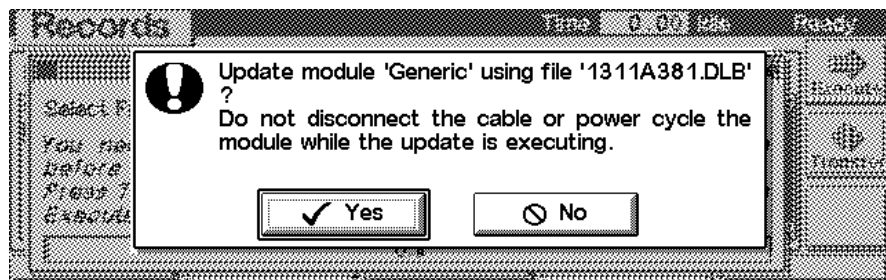

## 7 Control Module Screens for the Quaternary Pump

### Changing the serial number

In case the serial number of the module has to be added, use the **m**-key to open the menu **Enter Serial#**. The serial number becomes active after restart of the module.

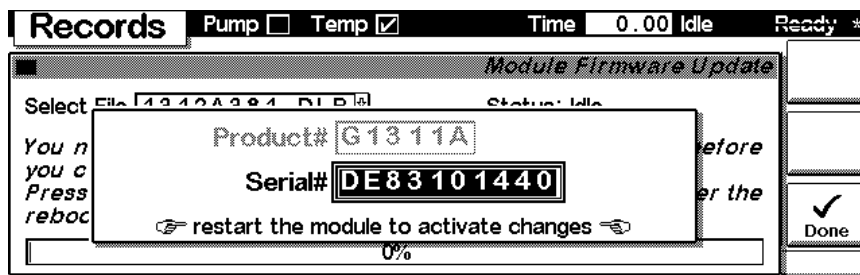
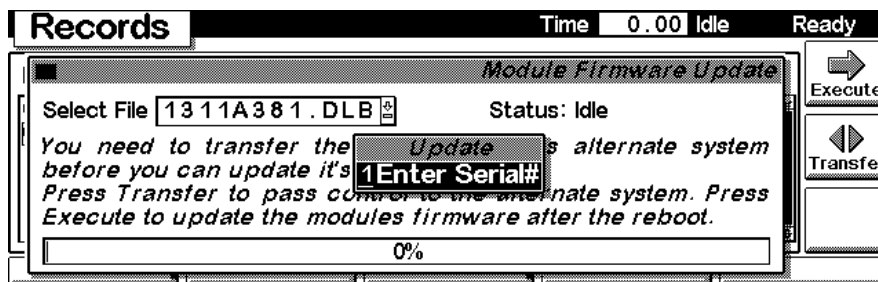

### Maintenance activities

On the Records screen use the F4 key (**Maint log**) to view and edit the maintenance logbook.

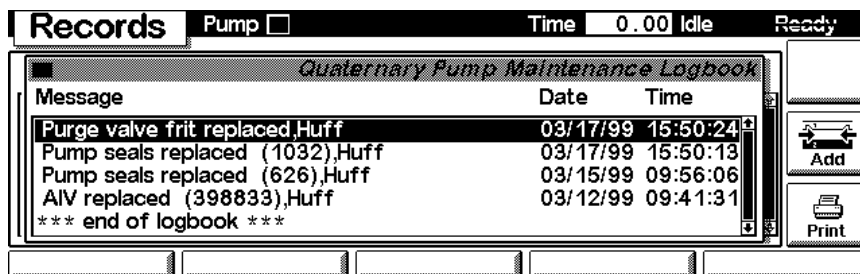

Use the F7 key (**Add**) to add new maintenance activities. If an activity is not listed, you can type the activity into the line “Add” using the control modules key pad.

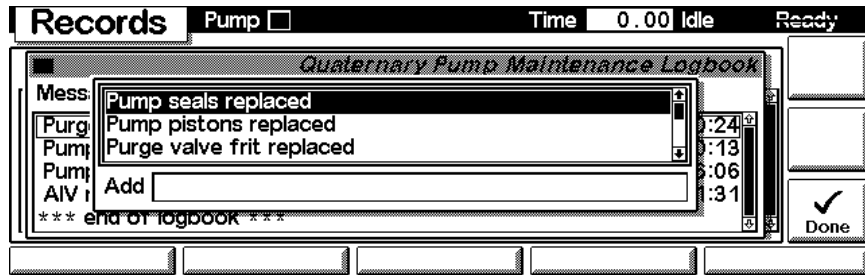

### Changing the Type

In order to change the type of the module (this may be necessary after an exchange of the mainbord) press 'm.m' in the **Test**-screen and select **Command**.

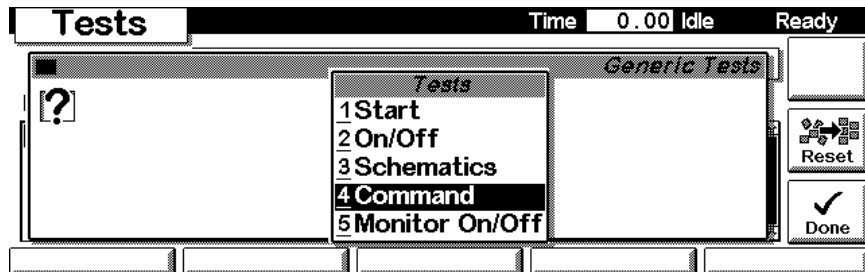

Enter 'TYPE G1311A' in the Instr-line in order to configure the module as a quaternary pump.

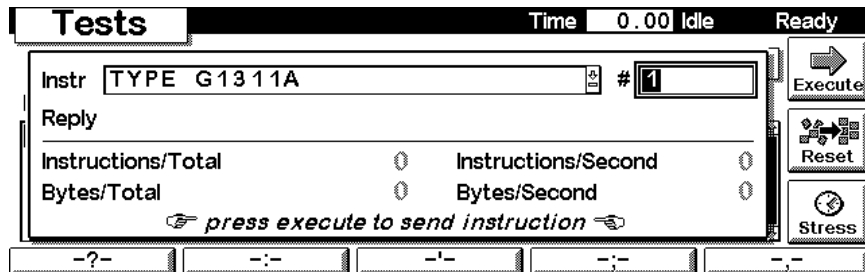

## 7 Control Module Screens for the Quaternary Pump

### Schematics

Select **Schematics** after pressing 'm.m' on the Test-screen in order to get a schematic overview of the quaternary pump.

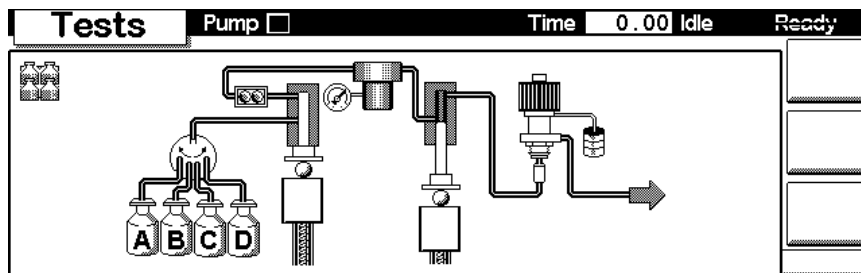



## Diagnostics and Tests

### Tests screen

Use the Esc key to receive **Views** on the F5 key. Choose **System** from the pull-down menu. Use the F3 key (**Tests**) to select the pump. Two tests are available to test the Agilent 1100 pumps.

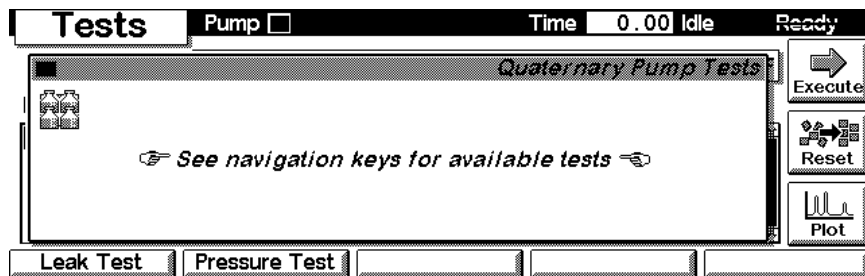

### Leak Test

Press F1 (Leak Test) on the Test screen to perform a leak test. Several steps like purging the system, setting up Isopropanol as solvent on channel D and blocking the purge valve outlet with a blank nut have to be performed before operating the leak test. For details use the 'i'-key to achieve context sensitive help, follow the instructions on the screen and refer to "[Running the Leak Test](#)" on page 91. For evaluating the pressure test refer to "[Evaluating the Results](#)" on page 87.

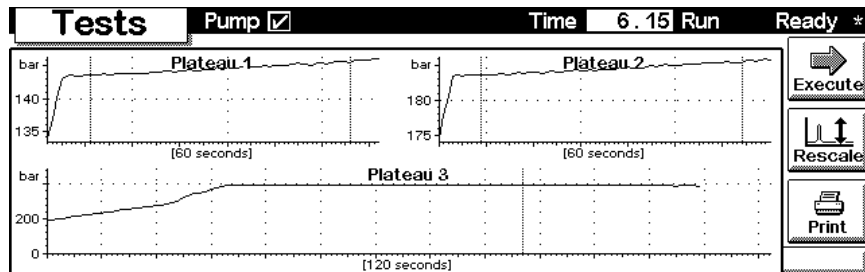

### Pressure Test

Use the F2 key (**Pressure Test**) to perform a pressure test of the system. Several steps like purging the system, setting up Isopropanol as solvent on channel D and blocking the column outlet with a blank nut have to be performed before operating the pressure test. For details use the 'i'-key to achieve context sensitive help, follow the instructions on the screen and refer to "[Running the Pressure Test](#)" on page 85. For evaluating the pressure test refer to "[Evaluating the Results](#)" on page 87.

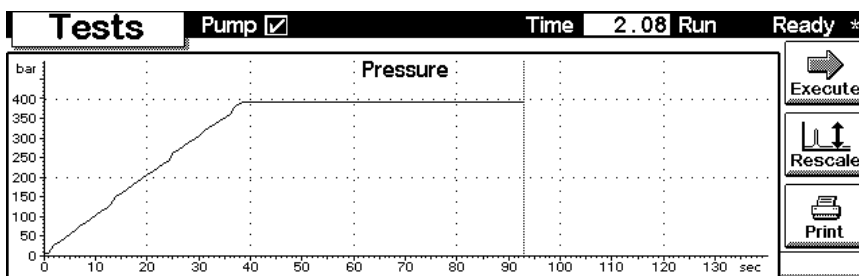

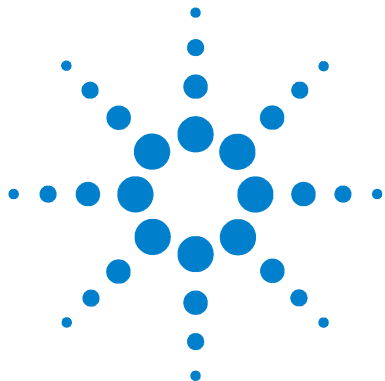

## 8 Specifications

Performance Specifications 260



## Performance Specifications

**Table 62** Performance Specification Agilent 1100 Series Quaternary Pump

Type	Specification
Hydraulic system	Dual plunger in series pump with proprietary servo-controlled variable stroke drive, floating plungers and active inlet valve
Setable flow range	0.001 – 10 ml/min, in 0.001 ml/min increments
Flow range	0.2 – 10.0 ml/min
Flow precision	< 0.3 % RSD (typically 0.15 %), based on retention time, at 1 ml/min
Pressure	Operating range 0 – 40 MPa (0 – 400 bar, 0 – 5880 psi) up to 5 ml/min Operating range 0 – 20 MPa (0 – 200 bar, 0 – 2950 psi) up to 10 ml/min
Pressure pulsation	< 2 % amplitude (typically < 1 %), at 1 ml/min isopropanol, at all pressures > 1 MPa (10bar)
Compressibility compensation	User-selectable, based on mobile phase compressibility
Recommended pH range	1.0 – 12.5, solvents with pH > 2.3 should not contain acids which attack stainless steel
Gradient formation	Low pressure quaternary mixing/gradient capability using proprietary high-speed proportioning valve Delay volume 800 – 1100 $\mu$ l, dependent on back pressure
Composition Range	0 – 95 % or 5 – 100 %, user selectable
Composition Precision	< 0.2 % SD, at 0.2 and 1 ml/min
Control and data evaluation	Agilent ChemStation for LC
Analog output	For pressure monitoring, 2 mV/bar, one output
Communications	Controller-area network (CAN), GPIB, RS-232C, APG Remote: ready, start, stop and shut-down signals, LAN optional
Safety and maintenance	Extensive diagnostics, error detection and display (through control module and Agilent ChemStation), leak detection, safe leak handling, leak output signal for shutdown of pumping system. Low voltages in major maintenance areas.

**Table 62** Performance Specification Agilent 1100 Series Quaternary Pump (continued)

---

GLP features	Early maintenance feedback (EMF) for continuous tracking of instrument usage in terms of seal wear and volume of pumped mobile phase with user-settable limits and feedback messages. Electronic records of maintenance and errors.
Housing	All materials recyclable.

---

## **8 Specifications**



## A Safety Information

General Safety Information	264
Lithium Batteries Information	267
Radio Interference	268
Sound Emission	269
Solvent Information	270
Agilent Technologies on Internet	271



# General Safety Information

The following general safety precautions must be observed during all phases of operation, service, and repair of this instrument. Failure to comply with these precautions or with specific warnings elsewhere in this manual violates safety standards of design, manufacture, and intended use of the instrument. Agilent Technologies assumes no liability for the customer's failure to comply with these requirements.

### General

This is a Safety Class I instrument (provided with terminal for protective earthing) and has been manufactured and tested according to international safety standards.

### Operation

Before applying power, comply with the installation section. Additionally the following must be observed.

Do not remove instrument covers when operating. Before the instrument is switched on, all protective earth terminals, extension cords, auto-transformers, and devices connected to it must be connected to a protective earth via a ground socket. Any interruption of the protective earth grounding will cause a potential shock hazard that could result in serious personal injury. Whenever it is likely that the protection has been impaired, the instrument must be made inoperative and be secured against any intended operation.

Make sure that only fuses with the required rated current and of the specified type (normal blow, time delay, and so on) are used for replacement. The use of repaired fuses and the short-circuiting of fuseholders must be avoided.

Some adjustments described in the manual, are made with power supplied to the instrument, and protective covers removed. Energy available at many points may, if contacted, result in personal injury.

Any adjustment, maintenance, and repair of the opened instrument under voltage should be avoided as much as possible. When inevitable, this should be carried out by a skilled person who is aware of the hazard involved. Do not



attempt internal service or adjustment unless another person, capable of rendering first aid and resuscitation, is present. Do not replace components with power cable connected.

Do not operate the instrument in the presence of flammable gases or fumes. Operation of any electrical instrument in such an environment constitutes a definite safety hazard.

Do not install substitute parts or make any unauthorized modification to the instrument.



Capacitors inside the instrument may still be charged, even though the instrument has been disconnected from its source of supply. Dangerous voltages, capable of causing serious personal injury, are present in this instrument. Use extreme caution when handling, testing and adjusting.

When working with solvents please observe appropriate safety procedures (e.g. goggles, safety gloves and protective clothing) as described in the material handling and safety data sheet by the solvent vendor, especially when toxic or hazardous solvents are used.

## Safety Symbols

Table 63 shows safety symbols used on the instrument and in the manuals.

**Table 63** Safety Symbols

Symbol	Description
	The apparatus is marked with this symbol when the user should refer to the instruction manual in order to protect the apparatus against damage.
	Indicates dangerous voltages.
	Indicates a protected ground terminal.

### **WARNING**

**A warning alerts you to situations that could cause physical injury or damage to the equipment. Do not proceed beyond a warning until you have fully understood and met the indicated conditions.**

---

### **CAUTION**

**A caution alerts you to situations that could cause a possible loss of data. Do not proceed beyond a caution until you have fully understood and met the indicated conditions.**

---

## Lithium Batteries Information

**WARNING**

Danger of explosion if battery is incorrectly replaced. Replace only with the same or equivalent type recommended by the equipment manufacturer. Lithium batteries may not be disposed-off into the domestic waste.

Transportation of discharged Lithium batteries through carriers regulated by IATA/ICAO, ADR, RID, IMDG is not allowed. Discharged Lithium batteries shall be disposed off locally according to national waste disposal regulations for batteries.

---

**WARNING**

Lithiumbatteri - Eksplosionsfare ved fejlagtig handling. Udskiftning må kun ske med batteri af samme fabrikat og type. Lever det brugte batteri tilbage til leverandoren.

---

**WARNING**

Lithiumbatteri - Eksplosionsfare. Ved udskiftning benyttes kun batteri som anbefalt av apparatfabrikanten. Brukt batteri returneres apparatleverandoren.

---

**NOTE**

Bij dit apparaat zijn batterijen geleverd. Wanneer deze leeg zijn, moet u ze niet weggoien maar inleveren als KCA.

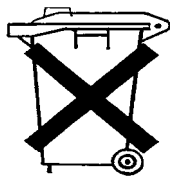

## **Radio Interference**

Never use cables other than the ones supplied by Agilent Technologies to ensure proper functionality and compliance with safety or EMC regulations.

### **Test and Measurement**

If test and measurement equipment is operated with equipment unshielded cables and/or used for measurements on open set-ups, the user has to assure that under operating conditions the radio interference limits are still met within the premises.

## Sound Emission

### **Manufacturer's Declaration**

This statement is provided to comply with the requirements of the German Sound Emission Directive of 18 January 1991.

This product has a sound pressure emission (at the operator position)  $< 70$  dB.

- Sound Pressure  $L_p < 70$  dB (A)
- At Operator Position
- Normal Operation
- According to ISO 7779:1988/EN 27779/1991 (Type Test)

## Solvent Information

Observe the following recommendations on the use of solvents.

### Flow Cell

Avoid the use of alkaline solutions (pH > 11) which can attack quartz and thus impair the optical properties of the flow cell.

### Solvents

Always filter solvents, small particles can permanently block the capillaries. Avoid the use of the following steel-corrosive solvents:

- Solutions of alkali halides and their respective acids (for example, lithium iodide, potassium chloride, and so on).
- High concentrations of inorganic acids like nitric acid, sulfuric acid especially at higher temperatures (replace, if your chromatography method allows, by phosphoric acid or phosphate buffer which are less corrosive against stainless steel).
- Halogenated solvents or mixtures which form radicals and/or acids, for example:

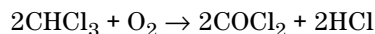

This reaction, in which stainless steel probably acts as a catalyst, occurs quickly with dried chloroform if the drying process removes the stabilizing alcohol.

- Chromatographic grade ethers, which can contain peroxides (for example, THF, dioxane, di-isopropylether) such ethers should be filtered through dry aluminium oxide which adsorbs the peroxides.
- Solutions of organic acids (acetic acid, formic acid, and so on) in organic solvents. For example, a 1-% solution of acetic acid in methanol will attack steel.
- Solutions containing strong complexing agents (for example, EDTA, ethylene diamine tetra-acetic acid).
- Mixtures of carbon tetrachloride with 2-propanol or THF.

## Agilent Technologies on Internet

For the latest information on products and services visit our worldwide web site on the Internet at:

<http://www.agilent.com/go/chem>

Select “Products” - “Chemical Analysis”

It will also provide the latest firmware of the Agilent 1100 series modules for download.

## **A Safety Information**



# Index

## A

accessory kit, 18  
accessory kit, degasser, 19  
active inlet valve, 102, 180  
active inlet valve drive, 216  
adapter, 102, 104  
air flow, 142  
algae growth, 36  
alternative seal material, 41  
ambient non-operating temperature, 16  
ambient operating temperature, 16  
analog output, 260  
APG remote connector, 24, 227  
ASIC - application-specific integrated circuit, 216  
assembling the main cover, 156  
AUTO mode, 209  
AUX output, 24

## B

ball-screw drive, 206  
battery, 217, 267  
baudrate setting, 232  
BCD board, 222  
bench space, 15  
blank nut, 85  
blockage, 71  
board connectors, 132  
bottle, 17  
bottle head assembly, 17, 167  
buffer, 204  
buffer application, 34  
buffer solution, 124, 204

## C

cable  
CAN, 18, 24  
GPIB, 24  
interface, 23

power, 17  
remote, 18  
signal, 18  
CAN cable, 24  
CAN interface, 226  
capillary, pump to injection device, 18  
changing solvents, 29  
ChemStation, 24  
cleaning the pump, 99  
compensation sensor open, 57  
compensation sensor short, 58  
composition precision, 260  
composition range, 260  
compressibility compensation, 42, 208, 260  
condensation, 15  
connecting tubes, 19  
connections, flow, 26  
continuous seal wash, 40, 204  
control module, 164  
EMF, 251  
firmware update, 252  
serial number change of MWD, 254  
tests, 257  
counter, EMF, 213  
counter, seal wear, 213  
cover parts, 169

## D

damaged parts, 17  
damper, 139  
damping unit, 139  
data bit settings, 232  
default address settings, 231  
degasser, 17  
delay volume, 20, 208  
delivery checklist, 17  
description, leak test, 89  
description, pressure test, 84  
dimensions, 15  
dual piston in-series design, 205

## E

early maintenance feedback (EMF), 212  
electrical connections  
descriptions of, 210  
electronic fuses, 217  
electrostatic discharge (ESD), 98  
EMF  
on control module, 251  
EMF counters, 213  
EMF limits, 214  
encoder missing, 72  
environment, 14, 15  
error  
zero solvent counter, 62  
error condition, 48  
error message  
wait timeout, 83  
error messages, 46, 49  
compensation sensor open, 57  
compensation sensor short, 58  
encoder missing, 72  
fan failed, 59  
ignition without cover, 60  
index adjustment, 79  
index limit, 78  
index missing, 80  
initialization failed, 82  
inlet valve fuse, 69  
inlet-valve missing, 73  
leak, 54  
leak senso open, 55  
leak sensor short, 56  
missing pressure reading, 66  
motor drive power, 71  
pressure above upper limit, 63  
pressure below lower limit, 64  
pump configuration, 67  
pump head missing, 77  
selection valve failed, 65  
servo restart failed, 76  
shut-down, 51

## Index

- stroke length, 81
- synchronization lost, 52
- temperature limit exceeded, 75
- temperature out of range, 74
- timeout, 50

error

- unknown error 2055, 62

ESD (electrostatic discharge) strap, 99

ESD wrist strap, 18

exchanging

- active inlet valve, 101, 102
- damper, 139
- fan, 142
- internal parts, 98
- leak sensor, 153
- LPM Board, 131
- multi channel gradient valve (MCGV), 124
- outlet ball valve, 101, 106
- pistons, 101, 114
- power supply, 148
- pump drive, 144
- pump seals, 101
- purge valve, 101, 108
- purge valve frit, 101, 108
- status light pipe, 155
- wash seals, 101, 116

Exchanging the Active Inlet Valve Cartridge, 104

## F

fan, 142

fan drive, 217

fan failed, 59

fan out, 227

features

- GLP, 261
- instrument layout, 212
- safety and maintenance, 260

firmware

- description, 220
- main system, 220
- resident system, 220

firmware update with control module, 252

flow connections, 26

flow precision, 260

flow range, 260

foam, 157

foam parts, 171

frequency range, 15

front of pump, 23

fuse, electronic, 217

## G

GPIO

- Default Addresses, 231

GPIO cable, 24

GPIO interface, 226

gradient formation, 260

gradient valve, 124

gradient valve drive, 216

## H

hex key set, 18

hexagonal key, 4 mm, 110, 111, 114, 116, 120, 123, 144

hints for successful use, 34

humidity, 16

hydraulic path, 168

hydraulic system, 260

## I

index adjustment, 79

index limit, 78

index missing, 80

initialization, 207

initialization failed, 82

inlet-valve fuse, 69

inlet-valve missing, 73

installation, pump module, 23

instrument status

- indicator, 48
- lamp, 48

interface

- CAN, 226
- GPIO, 226
- remote, 227
- RS-232C, 228

interface boards, optional, 222

interface cables, 23

interfaces, 217

introduction to the pump, 204

## L

laboratory bench, 15

lamp

- instrument status, 48

lamp, power supply, 47

lamp, status, 47

LAN cables, 201

LAN interface board, 223

leak, 54

leak converter, 216

leak parts, 173

leak sensor, 153

leak sensor open, 55

leak sensor short, 56

leak test, 46, 89

light pipe, status, 155, 172

line frequency, 15

line voltage, 15

liter counters, counter, liter, 213

lithium battery, 267

logbook, 49

low pressure pump main board (LPM), 131

low-pressure gradient, 204

low-pressure pump main board (LPM), 216

LPM board, 131

## M

main assemblies, 162

main assemblies, overview, 100

main board, 131

main power supply, 235

main power supply specification, 236

maintenance procedures, 213

materials in contact with mobile phase, 208

message

- ignition without cover, 60

missing parts, 17

missing pressure reading, 66

motor drive, 216

motor-drive power, 71

multi channel gradient valve (MCGV), 124

**N**

non-operating altitude, 16  
 non-operating temperature, 16  
 not-ready condition, 48

**O**

onboard battery, 217  
 operating Altitude, 16  
 operating temperature, 16  
 operational hints, vacuum degasser, 38  
 operational pressure range, 260  
 optimum performance, 20  
 optional interface board, 222  
 outlet ball valve, 106, 178  
 outlet capillary, 168  
 overview, pump, 205

**P**

parity settings, 233  
 parts  
   active inlet valve, 180  
   bottle head assembly, 167  
   control module, 164  
   cover, 169  
   damaged, 17  
   foam, 171  
   hydraulic path, 168  
   leak handling, 173  
   light pipes, 172  
   main assemblies, 162  
   missing, 17  
   outlet ball valve, 178  
   pump head, 174  
   pump head with seal wash, 176  
   pump housing and main  
     assemblies, 162, 164  
   sheet metal kit, 170  
   solvent cabinet, 166  
 parts identification  
   cables - LAN cables, 201  
 performance specification, 260  
 pH range, 260  
 physical specifications, 15  
 piston, 34, 114, 206  
 piston chamber, 205  
 plateaus, leak test, 94

power consideration, 14  
 power consumption, 16  
 power cords, 14  
 power light pipe, 172  
 power supply, 148  
 power supply indicator, 47  
 power supply lamp, 47  
 power switch, 23  
 power-input socket, 14  
 prerun condition, 48  
 pressure, 205  
   pressure above upper limit, 63  
   pressure below lower limit, 64  
   pressure converter, 216  
   pressure pulsation, 42, 209, 260  
   pressure range, 41  
   pressure sensor readings, 24  
   pressure test, 46, 84  
   pressure, operating range, 260  
 priming  
   with a pump, 29, 30  
   with a syringe, 29, 38  
   with the pump, 38  
 proportioning valve, high-speed, 205  
 PTFE frit, 18, 108  
 pump configuration, 67  
 pump drive, 144  
 pump head assembly, 174  
 pump head missing, 77  
 pump head with seal wash, 176  
 pump piston, 34  
 purge valve, 108  
 purge valve frit, 34  
 purging the pump, 29

**R**

rear of pump, 24  
 reassembling the pump head, 123  
 recommended pH range, 260  
 remote  
   signal distribution, 227  
 remote interface, 227  
 removing  
   pump head assembly, 110  
   the foam, 128  
   the top cover, 128  
 repairs, 101  
   using the ESD strap, 99

replacing the foam, 157  
 replacing the top cover, 157  
 restart without cover, 61  
 results, pressure test, 87  
 RS-232  
   cable kit to PC, 200  
 RS-232C communication settings, 232  
 RS-232C connection table, 228  
 RS-232C interface, 228  
 run mode, 48  
 running the leak test, 91  
 running the pressure test, 85

**S**

safety  
   standards, 16  
 safety light switch, 127, 130, 157  
 sapphire piston, 206  
 screwdriver pozidriv #1, 128, 139, 142,  
   144, 148, 153, 155, 157  
 seal  
   wear-in, 113  
 seal insert tool, 18  
 seal wash, 40, 204, 205  
 seal wash, when to use, 40  
 seal wear counters, 213  
 seal, alternative material, 41  
 seals, 111, 114, 116, 120, 123  
 security lever, 23, 98  
 selection valve failed, 65  
 serial number  
   entered on control module, 254  
 serial number change with control  
   module, 254  
 servo restart failed, 76  
 setable flow range, 260  
 setting  
   baudrate, 232  
   data bit, 232  
   forced cold-start, 233  
   parity, 233  
   RS 232C communication, 232  
   stay resident, 234  
 setting the address, 231  
 sheet metal kit, 170  
 shipping containers, 17  
 shut-down, 51  
 simple repairs, 98, 101

## Index

site requirements, 14  
snap fasteners, 26  
solvent bottle, 17  
solvent cabinet, 34, 166  
solvent filters  
  checking, 36  
  cleaning, 37  
  prevent blocking, 36  
solvent information, 35  
solvent inlet filters, 34  
solvent tubes, 19  
solvent tubes, degasser, 17  
sonic bath, 106  
specification  
  main power supply, 236  
  performance, 260  
  physical, 15  
spectrum  
  range, 244  
stack configuration, 20  
  front view, 20  
  rear view, 21  
status indicator, 46, 47  
status lamp, 47  
status light pipe, 155, 172  
stay resident settings, 234  
stroke length, 81  
stroke volume, 206, 209  
synchronization lost, 52  
syringe, 19  
syringe adapter, 19, 29

## T

temperature limit exceeded, 75  
temperature out of range, 74  
temperature sensor, 54  
tests on control module, 257  
timeout, 50  
top cover, 156, 157

## U

unknown error 2055, 62  
unpacking the pump, 17

## V

vacuum degasser, 17, 26, 34, 204  
valve frit, 108  
variable reluctance motor, 206  
variable stroke volume, 209  
velocity regulator, 18  
voltage range, 15

## W

wait timeout, 83  
wall socket, 14  
waste tube, 18, 19  
wear-in  
  procedure, 113  
weight, 15  
wide-ranging capability, 14  
wrench 1/4 inch, 85, 91, 106, 108, 110, 111, 114, 116, 120, 123, 124, 139  
wrench 14 mm, 102, 104, 106, 108, 131  
wrench 5 mm, 131  
wrench 7 mm, 131  
wrench, 1/4 - 5/16 inch, 18  
wrench, 14 mm, 18

## Z

zero solvent counter, 62





## **In This Book**

This manual contains technical reference information about the Agilent 1100 Series quaternary pump. The manual describes the following:

- installation,
- optimizing performance,
- diagnostics and troubleshooting,
- repairing,
- parts and materials,
- theory of operation, and
- screens of local control module.

