

**ALS 2016/ALS 2032  
INSTRUCTION MANUAL**

---

---

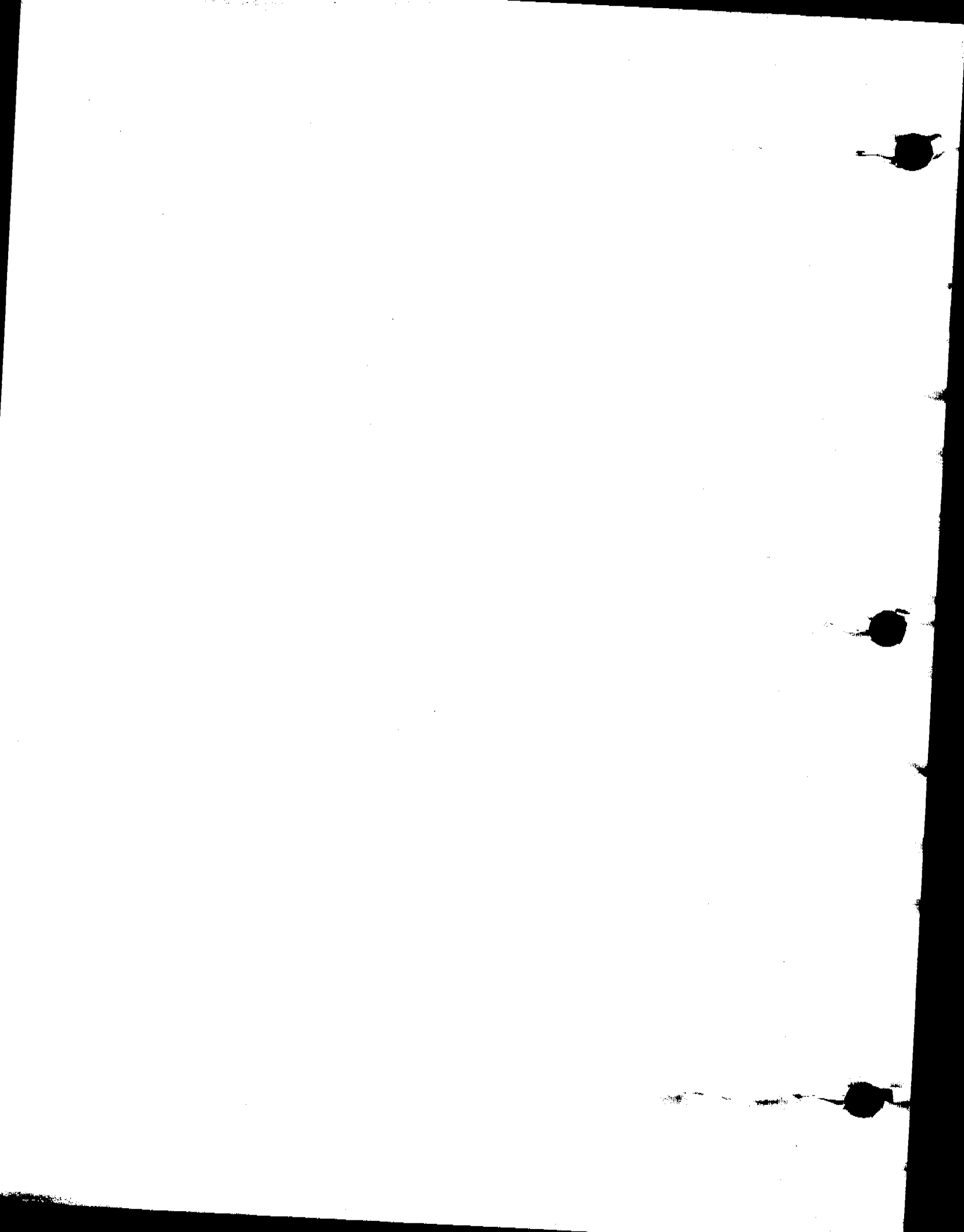

## INSTALLATION GUIDE

---

*IF* you are adding an  
ALS 2016 to your LSC 2000...

...go to Section 1, 2, and 3 of  
this ALS 2016/ALS 2032  
Instruction Manual.

---

*IF* you are adding an  
ALS 2032 to an existing  
LSC 2000/ALS 2016  
installation...

...go to Section 1, 2, and 4 of  
this ALS 2016/ALS 2032  
Instruction Manual.

---

*IF* you are installing all three  
components (LSC 2000/  
ALS 2016/ALS 2032) at the  
same time...

...follow the directions in  
Section 2 and Section 3 of your  
LSC 2000 User Manual.  
Then go to Section 1, 2, and 5  
of this ALS 2016/ALS 2032  
Instruction Manual.

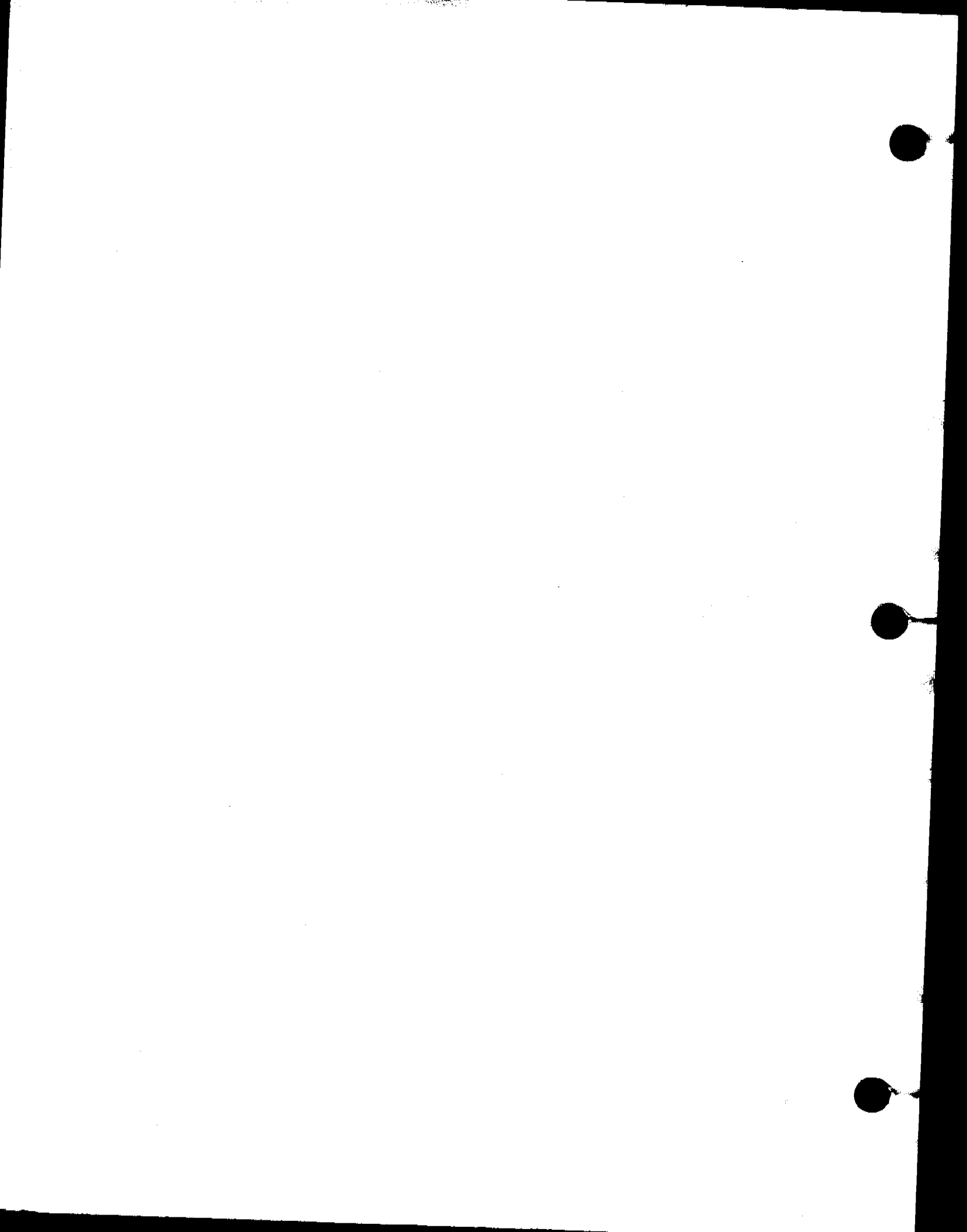

# TABLE OF CONTENTS

## **SECTION 1 - SAFETY SPECIFICATIONS**

- 1.1 Warnings ... 1
- 1.2 Specifications ... 1

## **SECTION 2 - SYSTEM SETUP**

- 2.1 Unpacking the System ... 3
- 2.2 ALS 2016/ ALS 2032 Kit Box Assemblies

## **SECTION 3 - CONNECTING ALS 2016 TO LSC 2000**

- 3.1 General ... 5
- 3.2 Site Preparations ... 5
- 3.3 Power Requirements ... 5
- 3.4 Purge Gas and Sample Connections from ALS 2016 to LSC 2000 ... 5
- 3.5 Electronic Interconnection to LSC 2000 ... 7
  - 3.5.1 Interconnection to Gas Chromatograph ... 8
- 3.6 Sampler Connections ... 8
  - 3.6.1 Purge Lines ... 8
  - 3.6.2 Sample Valves ... 10
  - 3.6.3 Fritted/ Fritless Disc Spargers and Needle Spargers
  - 3.6.4 Drain Lines ... 9
- 3.7 Leak Checking ... 9
- 3.8 Automatic Drain Assembly Installation ... 11
  - 3.8.1 Upper Drain Assembly Installation ... 12
  - 3.8.2 Lower Drain Assembly Installation ... 14
  - 3.8.3 Internal Drain Line Connections ... 14
  - 3.8.4 Electronic Connections ... 16
  - 3.8.5 Leak Checking Automatic Drain Assembly ... 16

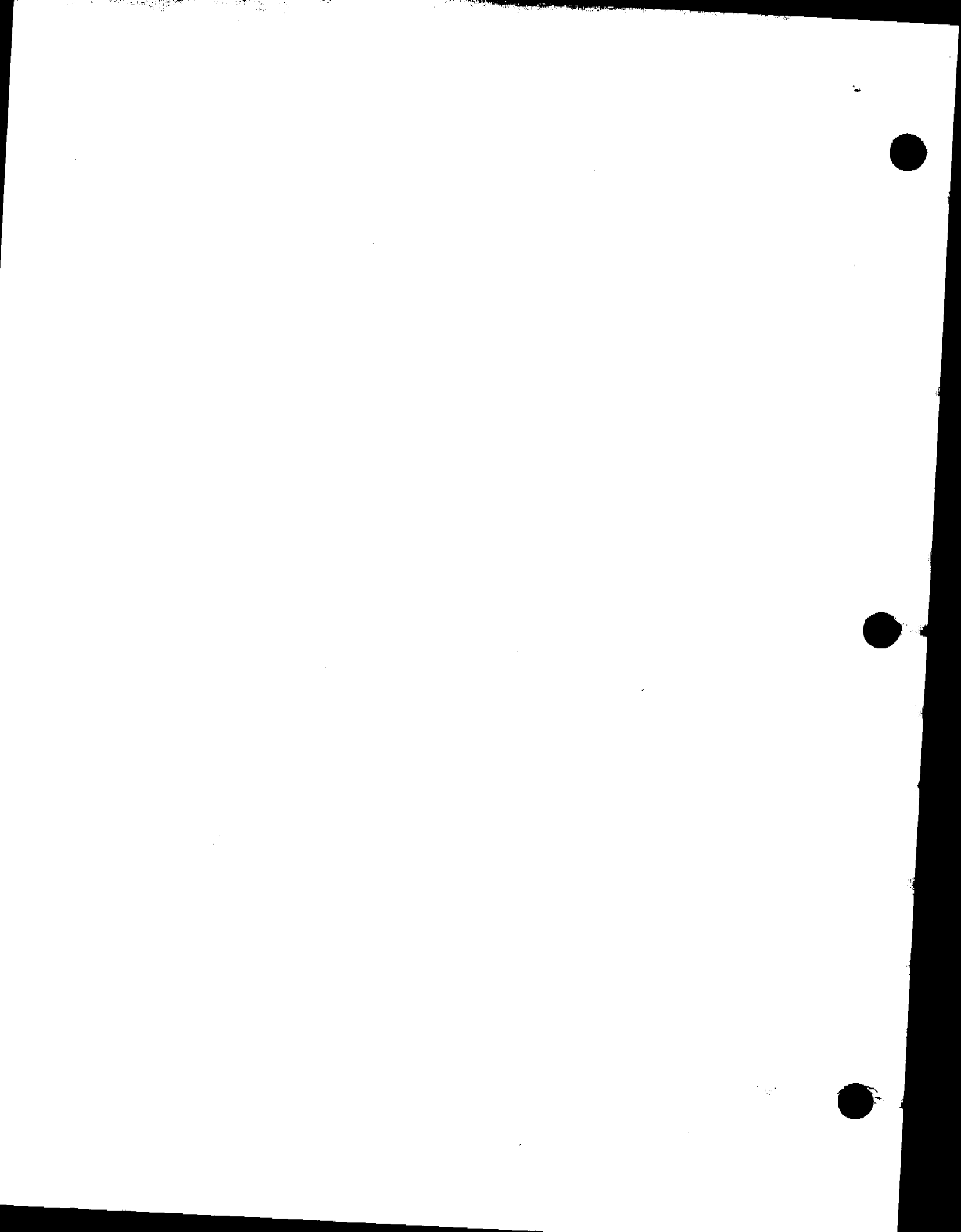

**SECTION 4 - CONNECTING ALS 2032 TO LSC 2000/ ALS 2016**

- 4.1 General ... 17
- 4.2 Site Preparations ... 17
- 4.3 Power Requirements ... 17
- 4.4 Purge Gas and Sample Connections from ALS 2032 to LSC 2000 ... 18
- 4.5 Electronic Interconnection to LSC 2000 ... 20
  - 4.5.1 Interconnection to Gas Chromatograph ... 20
- 4.6 Sampler Connections ... 20
  - 4.6.1 Purge Lines ... 20
  - 4.6.2 Sample Valves ... 21
  - 4.6.3 Fritted/ Fritless Disc Spargers and Needle Spargers ... 21
  - 4.6.4 Drain Lines ... 22
- 4.7 Leak Checking ... 22

**SECTION 5 - COMPLETE SYSTEM INSTALLATION  
LSC 2000/ ALS 2016/ ALS 2032**

- 5.1 General ... 25
- 5.2 Site Preparations ... 25
- 5.3 Power Requirements ... 25
- 5.4 Purge Gas and Sample Connections from ALS 2016 to ALS 2032 to LSC 2000 ... 25
- 5.5 Electronic Interconnection to LSC 2000 ... 27
  - 5.5.1 Interconnection to Gas Chromatograph ... 28
- 5.6 Sampler Connections ... 28
  - 5.6.1 Purge Lines ... 28
  - 5.6.2 Sample Valves ... 28
  - 5.6.3 Fritted/ Fritless Disc Spargers and Needle Spargers ... 29
  - 5.6.4 Drain Lines ... 29
- 5.7 Leak Checking ... 30

**SECTION 6 - ROUTINE OPERATING PROCEDURES**

- 6.1 Sample Loading ... 33
  - 6.1.1 Syringe Handling Technique ... 34
- 6.2 Control Sequence ... 34
- 6.3 Bake Gas Bypass ... 35
- 6.4 Sampler Clean-Up ... 35

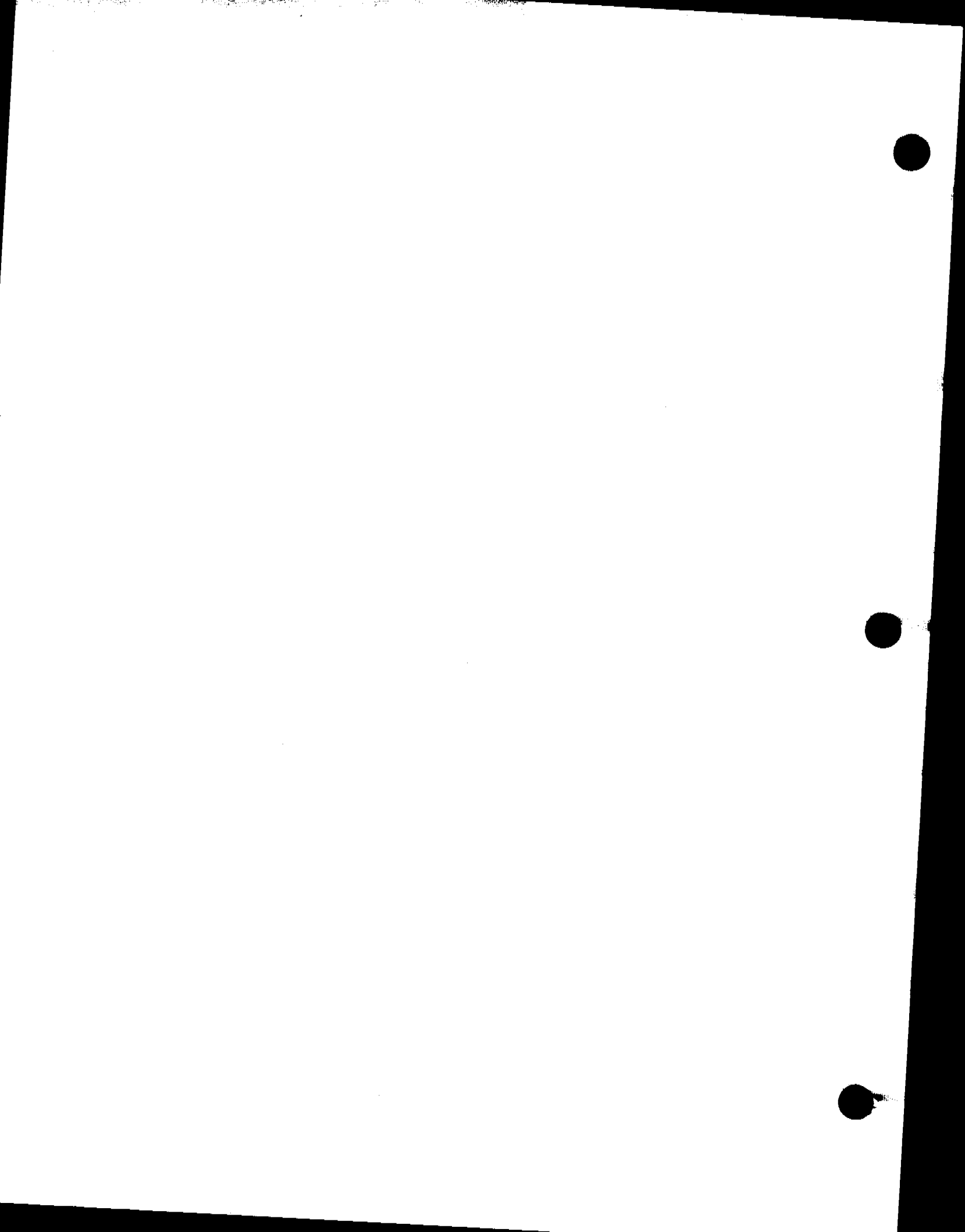



**SECTION 7 - ALS 2016 MICROPROCESSOR CONTROL**

- 7.1 General Description ... 36
- 7.2 Powering Up the System ... 36
- 7.3 Running Self Tests ... 36
- 7.4 Configuring LSC 2000 to Acknowledge ALS 2016  
and/ or ALS 2032 ... 39
- 7.5 Setting Sample Start and Stop Positions ... 41
- 7.6 Stepping the Multi-Position Valve ... 41
- 7.7 Using Method Scheduling ... 42
- 7.8 Running Samples ... 44

**SECTION 8 - SAMPLE HEATER INSTALLATION**

- 8.1 Interlocking Automatic Sample Heater with ALS 2016  
or ALS 2032 ... 47
- 8.2 Electrical Connection to ALS 2016 or ALS 2032 ... 47
- 8.3 Power Requirements ... 48
- 8.4 Kit Box Assembly ... 48
- 8.5 Sample Heaters ... 48
- 8.6 Pocket Heater Installation ... 49
- 8.7 Tube Heater Installation ... 50
- 8.8 Sample Heater Numbering ... 50
- 8.9 Configuring LSC 2000 to Acknowledge Sample Heater ... 51
  - 8.9.1 Configuring LSC 2000 to Acknowledge  
Sample Heater (1.9 ROM) ... 52
  - 8.9.2 Configuring LSC 2000 to Acknowledge  
Sample Heater (2.0 ROM) ... 53
- 8.10 Sample Heater Parameters ... 56
- 8.11 Heated/ Unheated Sample Runs ... 58
- 8.12 Storing Sample Heaters ... 58
- 8.13 Ordering Sample Heater Replacement Parts ... 59

**SECTION 9 - MAINTENANCE, SERVICE AND REPLACEMENT  
PARTS**

- 9.1 Routine Maintenance ... 60
  - 9.1.1 System Clean-Up ... 60
  - 9.1.2 Leak Checking ... 60
- 9.2 Installing 3/4" Fittings and Glassware Kits ... 61
- 9.3 ALS 2016/ ALS 2032 Spare Parts List ... 64

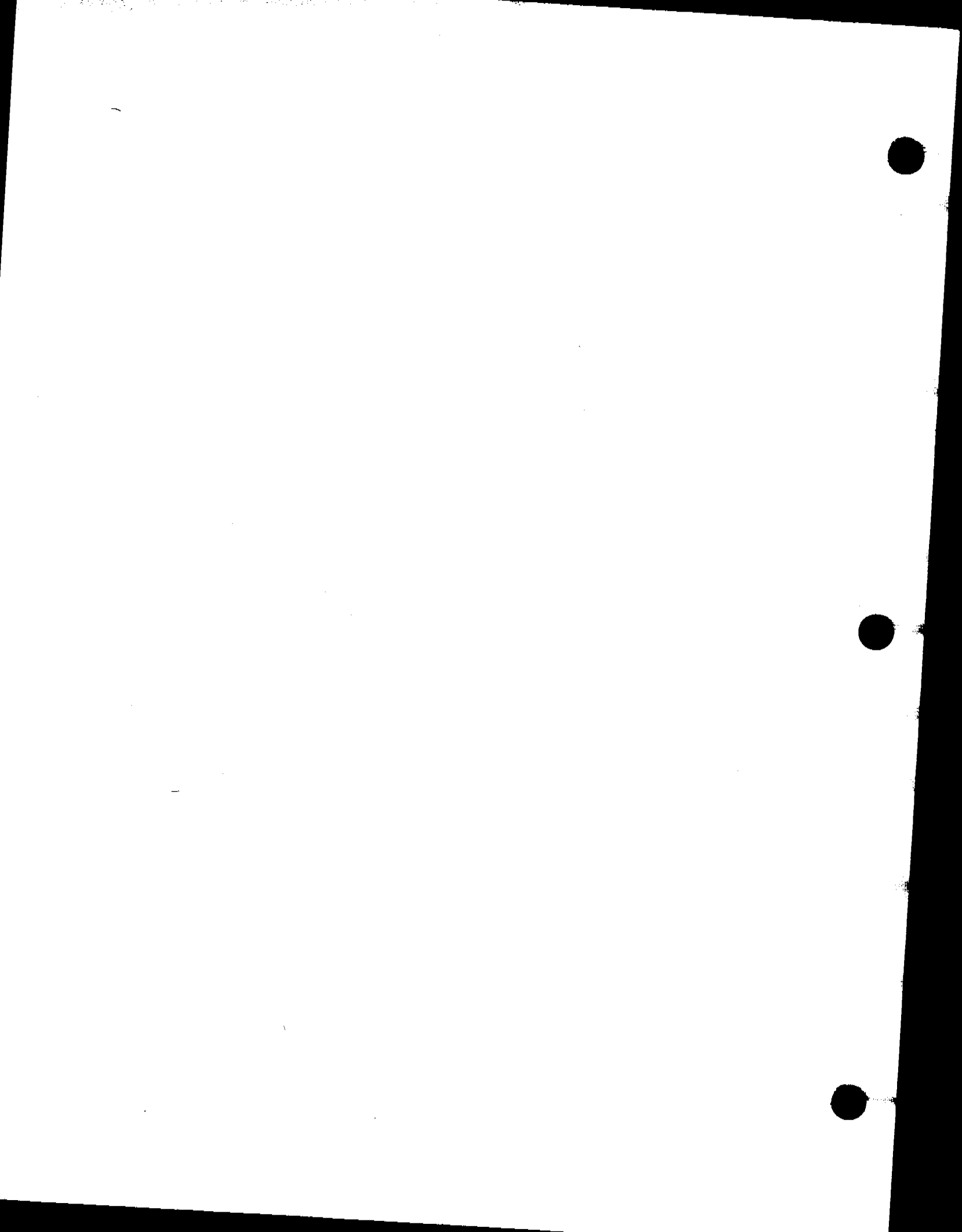

**SECTION 10 - TROUBLESHOOTING**

10.1 ALS 2016/ ALS 2032 Electronic Problems ...67

10.2 Automatic Sample Heater Electronic Problems ...69

**SECTION 11 - DIAGRAMS**

**SECTION 12 - INDEX**

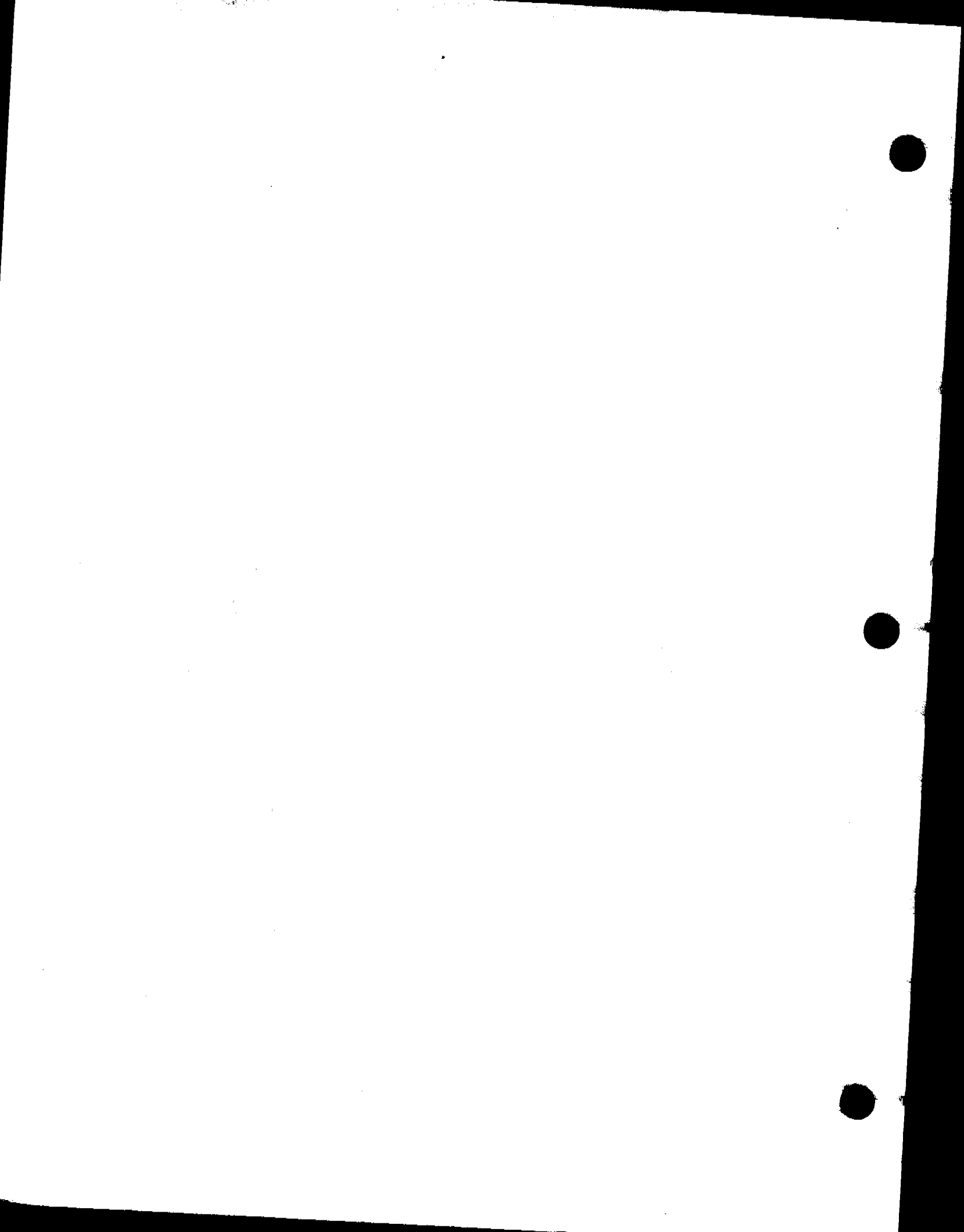

**SECTION 1**  
**SAFETY SPECIFICATIONS**

---

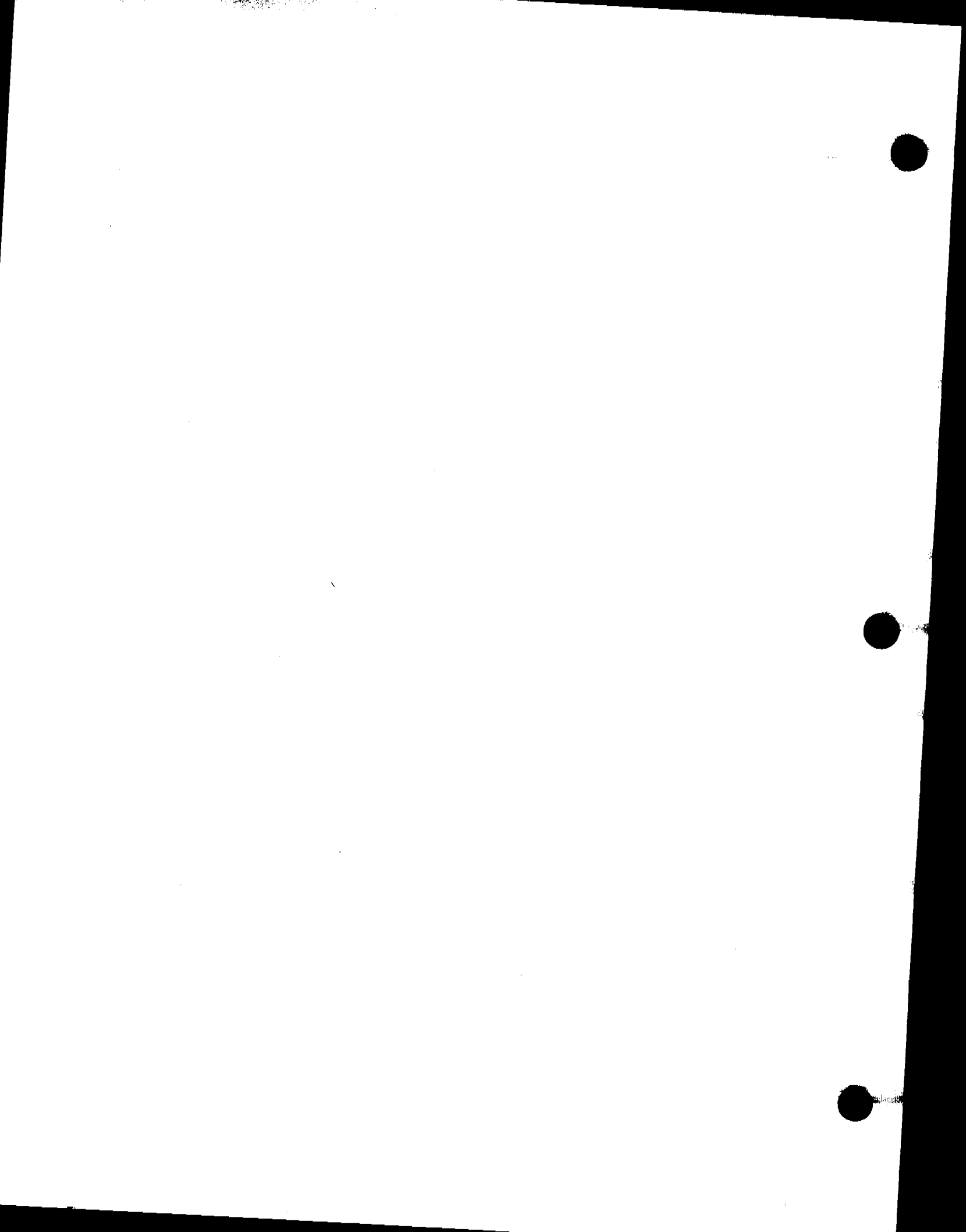

## 1.1 Warnings

The ALS 2016 meets Class 1 safety requirements.

### = WARNING =

This instrument contains a heater and a heated transfer line. Touching the heater or transfer line could cause a burn. The heater and transfer line will be HOT when the instrument is on.

### = WARNING =

Potentially lethal voltage exists inside this instrument. Unplug the instrument from power source and disconnect all I/O cables before servicing.

## 1.2 Specifications

### Flow System:

Valved purge and sample gas flow system with independent sampler loops for each of the sixteen positions. Interconnecting tubing for interface is included.

### Valve/Sample Line Heating System:

The position selector valve and all sample lines are heated. Temperature control is variable from ambient to 175°C. Temperature is set through the LSC 2000 microprocessor.

### Samplers:

5 ml or 25 ml sampler volume. All glass construction using medium porosity glass frits or narrow bore glass tubing. Includes manual 3-way valve for sample load/empty.

### Valve:

Electrically-actuated 34-port valve selects sampler position. Valve position is indicated on the LSC 2000 display.

### Tubing:

All lines are 1/16" nickel. The transfer lines are 36". All sample lines are heated.

### I/O Interface:

ALS 2016 Logic Board and Interface Cable to LSC 2000 are included.

### Environment Requirements:

Operating temperature: 10°C to 30°C  
Storage temperature: -20°C to 40°C  
Relative humidity: 10 - 90% with no condensation

### Power Requirements:

120V or 220V  $\pm$  10%, 50 or 60 Hz  $\pm$  1%  
**2016:** 720 watts  
**2032:** 840 watts

# 1 SAFETY SPECIFICATIONS

## 1.2 Specifications (cont.)

**Size:**

**ALS 2016**

Height: 27-1/8" (69 cm)

Width: 15-3/8" (39 cm)

Depth: 11-5/8" (30 cm)

**ALS 2032**

Height: 27-1/8" (69 cm)

Width: 15-3/8" (39 cm)

Depth: 11-5/8" (30 cm)

**Weight:**

**ALS 2016**

Net 53 lbs. (24 kg), shipping weight 65 lbs. (29.5 kg)

**ALS 2032**

Net 53 lbs. (24 kg), shipping weight 65 lbs. (29.5 kg)



**SECTION 2**  
**SYSTEM SETUP**

---



**2.1  
Unpacking the  
System**

Remove the accessory box and the unit from the shipping carton. Check the contents against the packing list to be sure that the shipment is complete.

**IMPORTANT**

Carefully examine the unit. If there is any visible damage to the unit or the accessories, notify both the shipping carrier and Tekmar Company immediately. Do not continue the installation until directed to do so by an Tekmar representative. Save all shipping materials until proper operation of the instrument is verified.

Failure to comply with these instructions may void your warranty for components damaged in shipment. If any shortage of materials is found, please notify our Service Department toll free at (800) 874-2004; locally or outside the U.S. call (513) 247-7002.

## **SYSTEM SETUP 2**

### **2.2 ALS 2016/ ALS 2032 Kit Box Assemblies**

A kit box containing parts needed to install each unit accompanies each ALS 2016 and ALS 2032. Check the contents of the kit box against the packing list before beginning installation.

**SECTION 3**  
**CONNECTING ALS 2016 TO LSC 2000**

---



*Before you begin:*

**\*\* IMPORTANT \*\***

If you are installing an ALS 2032 to an existing LSC 2000 and ALS 2016, follow the instructions in Section 4. Instructions for a complete LSC 2000/ALS 2016/ALS 2032 installation are located in Section 5.

**3.1  
General**

This section contains instructions to connect an ALS 2016 to your LSC 2000. It is intended to be as thorough as possible. However, certain specific items will vary depending on the make and model of the gas chromatograph used. If in doubt on any point, please contact our Service Department toll free at (800) 874-2004, and locally or outside the U.S. at (513) 761-0633 for assistance. When installation is not performed or directed by Tekmar personnel, the operator must be thoroughly familiar with this section before proceeding.

**3.2  
Site  
Preparations**

The ALS 2016 can be placed on either side of the LSC 2000. The transfer line bundle is attached to the rear panel of the ALS 2016 by cable ties. Cut the ties and uncoil the lines. Turn off the LSC 2000, remove the power cord, and allow the heated valve and lines time to cool.

**3.3  
Power  
Requirements**

The power source required for the ALS 2016 is 50 or 60 Hz, single phase at 120V or 220V  $\pm$  10%. The maximum current draw is 6 amps for the ALS 2016 (110V). Maximum power consumption is 720 watts for the ALS 2016. The AC power cord is terminated with a 3-prong straight blade plug and requires a matching receptacle.

**3.4  
Purge Gas and  
Sample  
Connections  
from ALS 2016  
to LSC 2000**

Refer to Figure 1 in this section and the LSC 2000 & ALS 2016 Flow Diagram in the back of the manual.

- 1) Remove the trap compartment cover panel by loosening the two 1/4 turn screws and pulling the panel towards the front of the instrument.
- 2) Remove the left side panel cover by loosening four 1/4 turn phillips head screws and sliding the panel back about one inch, then out.

### 3 CONNECTING ALS 2016 TO LSC 2000

#### 3.4 Purge Gas and Sample Connections From ALS 2016 to LSC 2000 (cont.)

- 3) Remove the valve oven cover by removing the two truss head screws and loosening the two 1/4 turn phillips head screws.

**CAUTION:** The valve oven cover is well insulated and may be hot. Use caution when removing it from the instrument.

- 4) Loosen the valve heater block set screw using a 1/4" wrench.
- 5) Pull the valve heater block off the valve and move it away to get to the transfer line connections.
- 6) Remove the glassware, sample valve, and sample needle from the front of the LSC 2000 and remove the cover over the sample mount fitting.

**NOTE:** The LSC 2000 contains glass-lined stainless steel tubing. This tubing must not be bent or the glass lining will break. These lines can be identified by their blackened appearance.

- 7) Unfasten the LSC 2000 sample line (glass-lined tubing) at the sample mount fitting on the front of the unit and on the left side of the gold-plated sample tee inside the valve oven.
- 8) Carefully back the line through the front panel into the valve oven area.
- 9) Remove the line from the instrument and store it in a safe place.
- 10) Disconnect the LSC 2000 purge line from the 1/16" Swagelok union near the front of the valve oven.
- 11) The ALS 2016 transfer line bundle contains a purge line with a Swagelok nut and a sample line with a Valco nut. Slide the bundle through the hole in the rear panel of the LSC 2000 labeled FROM ALS (next to the heated transfer line to the GC).



### 3.4 Purge Gas and Sample Connections From ALS 2016 to LSC 2000 (cont.)

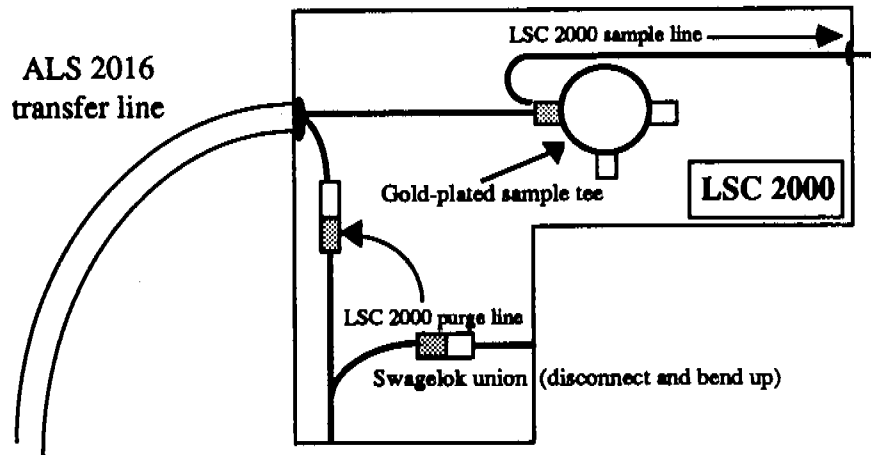

**Figure 1**

- 12) Connect the ALS 2016 purge line to the 1/16" Swagelok union near the front of the valve oven.
- 13) Connect the ALS 2016 sample line to the gold-plated sample tee.

**NOTE:** The other side of the gold-plated sample tee contains glass lined tubing. Care should be taken while installing the sample line to prevent fracturing the glass lining of this other line.

- 14) Continue through Sections 3.5-3.7 before reinstalling the valve heater block and all the covers, because you will need to leak check internal fittings. Leak checking is described in Section 3.7.

### 3.5 Electronic Interconnection to LSC 2000

The ALS 2016 Logic Board must be installed in the LSC 2000 Electronics Module. It may occupy any available card slot other than the two outermost card slots which are reserved for the Power Supply Board and the LSC 2000 Logic Board.

- 1) Turn off and unplug the LSC 2000.
- 2) Remove one of the card slot covers and insert the ALS 2016 Logic Board until it is fully seated in the connector (it will be flush with all other card slot covers).
- 3) Tighten the screw connectors to secure the board.

### 3 CONNECTING ALS 2016 TO LSC 2000

#### 3.5 Electronic Interconnection to LSC 2000 (cont.)

- 4) Connect one end of the 37 pin D-type Logic Cable connector to the ALS 2016 Logic Board.
- 5) Connect the other end of the cable to the rear of the ALS 2016 at the 37 pin D-type connector.
- 6) Plug in the main power cords for the LSC 2000 and ALS 2016 and power up both instruments.

#### 3.5.1 Interconnection to Gas Chromatograph

To operate fully automatically, the LSC 2000 must be wired to start the GC and data system, and to accept a ready signal from the GC. Refer to the GC Interface Cable Installation Instructions which accompany the cable.

#### 3.6 Sampler Connections

Please review the instructions below for 1/2" glassware connections and refer to the ALS 2016 Front View diagram in the back of the manual. The lines for the purge and the sample sides of the glassware are preassembled. The sample valve and needles are unassembled when shipped. For installing 3/4" glassware kits, refer to Section 9.2.

#### 3.6.1 Purge Lines

- 1) Connect the nickel purge lines to each of the front panel purge bulkheads.

**NOTE:** a) The top row of purge lines coils to the left of the purge bulkhead.  
b) The bottom row coils to the right of the purge bulkhead.

#### 3.6.2 Sample Valves

The sample valve assemblies and needles are not connected when shipped.

- 1) Insert a needle into the bottom of each black sample valve. *Take care not to lose the Teflon® ferrules and nuts on the needle.*

**NOTE:** a) The top row valves have an additional port on the right.  
b) The bottom row valves have an additional port on the left.

### **3.6.2 Sample Valves (cont.)**

- 2) Slide the nut (with the 2 piece ferrule inside) up and screw it onto the sample valve to secure the needle.
- 3) Insert each assembly into each position slot on the front of the unit.

### **3.6.3 Fritted/Fritless Disc Spargers and Needle Spargers**

Refer to the ALS 2016 Front View diagram in the back of the manual.

- 1) Grasp the glassware by the end of the purge gas inlet.
- 2) Place the 1/2" sample nut and ferrule over the sample inlet side of the glassware.
- 3) Slide the glassware up over the needle and into the sample mount until the glassware seats in the fitting.
- 4) Withdraw the glassware 1-2 mm and finger tighten. Failure to set this clearance will result in breakage of the glassware.
- 5) Adjust the height of the sample needle so that it is about 1-2 mm above the surface of the frit in a frit sparger sampler or above the bottom of the vessel in a needle sparge sampler.
- 6) Tighten the 1/16" nut at the top of the sample mount. This should be finger tight only because it contains a Teflon® ferrule.
- 7) Connect the 1/4" fitting on the nickel purge line to the purge inlet side of the glassware and finger tighten the nut.
- 8) Leak check according to Section 3.7.

### **3.6.4 Drain Lines**

If equipped with automatic drain, the 1/16" Teflon® lines will pass through the front panel immediately adjacent to the sample valves. Connect these lines to the side port of the sample valve.

### **3.7 Leak Checking**

The LSC 2000/ALS 2016 is not a leak prone system, however, it is very leak sensitive. Utmost care should be taken to ensure that the system is leak tight. All fittings should be thoroughly leak checked.

**3.7  
Leak Checking  
(cont.)**

The simplest and most effective way to leak check a system is by bubble leak check.

To begin a complete leak check, place a 1/16" Swagelok cap nut (included in the kit box) on the LSC 2000 vent fitting and tighten it wrench tight.

**CAUTION:** Do *not* use any type of soap solution (e.g. Snoop or Detect) to leak check. If these solutions get into the lines, increased background and adsorption are likely to occur.

Leak checking is best accomplished with an electronic thermal conductivity detector.

**NOTE:** Electronic leak detectors do not work well when using nitrogen as the purge gas. If possible, use helium when leak checking.

If an electronic leak detector is not available, a 1:1 solution of isopropanol:water may be used, if done so sparingly.

Complete the following steps for each individual glassware:

- 1) Put 5ml of organic-free water in the purge vessel.
- 2) Press STEP to advance the unit to Purge mode.
- 3) Press HOLD to keep the system in Purge mode. This procedure causes the system to pressurize.
- 4) Time the bubbling in the purge vessel. If the bubbling stops between 3 to 7 minutes, the system is leak tight and no further leak checking is necessary.

**TO DIAGNOSE A LEAK:**

First make sure the leak is not at the capped vent. The Swagelok nut may be worn out.

- a) If the bubbling stops before 3 minutes have elapsed, it is likely that there is a leak upstream of the purge vessel (before the gas flow reaches the purge vessel). If a leak is indicated, leave the system in purge with the cap on the vent. Capping the vent causes an increase in pressure which will exaggerate the leak and make it easier to find.

### 3.7 Leak Checking (cont.)

- b) If the bubbling continues after 7 minutes, a leak downstream of the purge vessel is indicated (after the gas flow leaves the purge vessel).
- 5) Remove the trap cover at the front left side of the LSC 2000. Check the fittings at the top and the bottom of the trap.
- 6) Check the 10 fittings inside the valve oven of the LSC 2000. Take note to check the two connections that you just made to the LSC 2000 from the ALS 2016.
- 7) Remove the rear compartment cover panel of the ALS 2016.
- 8) Check the following 5 fittings around the glassware on the front of the ALS 2016 (See ALS 2016 & ALS 2032 Flow Diagram in the back of the manual):
  - a. purge line fitting (at glassware)
  - b. purge bulkhead (at unit)
  - c. sample glassware fitting
  - d. sample needle nut
  - e. sample valve (3 port)
- 9) Check the purge bulkhead and the sample bulkhead fittings on the inside of the front panel of the ALS 2016.
- 10) Check the 18 Swagelok fittings inside the LSC 2000. (See LSC 2000 Leak Check Diagram in the LSC 2000 User Manual).
- 11) Leak check each sample position in the ALS 2016.
- 12) Reinstall the valve heater block on the valve in the LSC 2000. Replace the valve oven cover first, left side panel next, and then the trap cover.

### 3.8 Automatic Drain Assembly Installation

These instructions are for ALS 2016/ALS 2032 customers who purchased this assembly separately and need to install it.

Before beginning installation, check to make sure all the necessary parts are included in the assembly box. They are:

- 1) Top Drain Manifold Assembly
- 2) Bottom Drain Manifold Assembly
- 3) #10 Locking Nuts (4)

### **3** *CONNECTING ALS 2016 TO LSC 2000*

#### **3.8 Automatic Drain Assembly Installation (cont.)**

- 4) Brass Nut (1)
- 5) Brass Ferrule (1)
- 6) 1/8" Copper Tubing (31-1/2")
- 7) 1/8" Copper Tubing (11-1/2")

You will need the following tools for assembly:

- 1) 3/8" open-end wrench
- 2) 7/16" open-end wrench
- 3) Phillips screwdriver

- The ALS 2016 and the ALS 2032 are referred to as "unit" in these instructions.
- "Left side" or "right side" refers to viewing the unit from the front.

- 1) Turn off the power to the LSC 2000 and the ALS 2016 and/or ALS 2032.
- 2) Position yourself to gain access to both sides of the unit.
- 3) Remove the white compartment cover panel of the unit by loosening the ten 1/4 turn screws (4 on each side, 2 on the back). Pull the panel up and towards you, away from the unit.

Refer to Figure 2 on the following page.

- 1) Locate the upper drain manifold assembly in the kit box. Of the two assemblies, it has a bracket mounted to it.
- 2) Remove the strap holding the drain lines and wire bundle together. Do not remove the straps holding the wire bundle together.
- 3) Locate the two mounting studs on the back side of the front panel. They are located below heated transfer line position #2 and position #8.
- 4) Place the drain assembly onto the studs (with the Teflon® drain lines up) and tighten it down with two of the #10 locking nuts and a 3/8" wrench.

#### **3.8.1 Upper Drain Assembly Installation**

### 3.8.1 Upper Drain Assembly Installation (cont.)

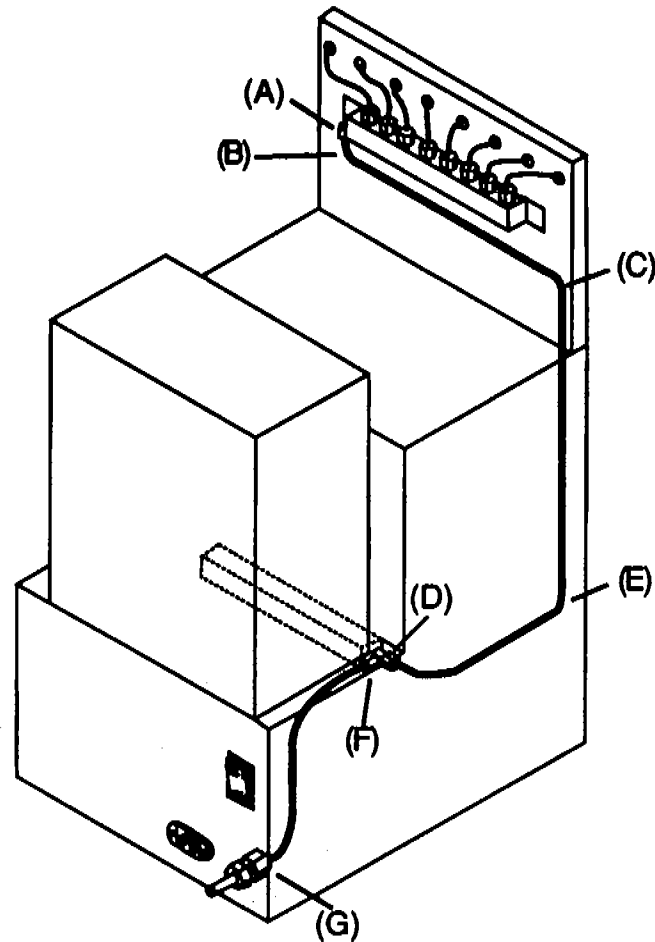

**Figure 2**

- 5) Locate the black snap-in grommets in the drain line holes in the front panel. These holes are directly to the right of each sample valve assembly.
- 6) Push the grommets out from the back.
- 7) Carefully feed the appropriate drain line through the appropriate hole.
- 8) Hold the grommet on the outside of the front panel, push the drain line through the side slot of the grommet, and snap the grommet back into the hole.
- 9) Fasten the drain line to the open port on the right side of each sample valve assembly and finger tighten.
- 10) Follow steps 5-9 for all eight drain lines.

### **3** *CONNECTING ALS 2016 TO LSC 2000*

#### **3.8.2 Lower Drain Assembly Installation**

Refer to Figure 2 on the previous page.

- 1) Locate the lower drain assembly in the kit box. (Of the two assemblies, the lower drain assembly has no bracket mounted to it).
- 2) Remove the strap holding the drain lines and wire bundle together. Do not remove the straps holding the wire bundle together.
- 3) Locate the two mounting studs protruding from the bottom panel of the valve oven (look up and under).
- 4) Slide this drain assembly onto the studs (with the Teflon® drain lines towards the front panel) and tighten it down with two of the #10 locking nuts and a 3/8" wrench or nut driver.
- 5) Locate the black snap-in grommets in the drain line holes in the front panel. These holes are positioned directly to the left of each sample valve assembly.
- 6) Push the grommets out from the back.
- 7) Carefully feed the appropriate drain line through the appropriate hole.
- 8) Hold the grommet on the outside of the front panel, push the drain line through the side slot of the grommet, and snap the grommet back into the hole.
- 9) Fasten the drain line to the open port on the left side of each sample valve assembly and finger tighten.
- 10) Follow steps 5-9 for all eight drain lines.

#### **3.8.3 Internal Drain Line Connections**

Refer to Figure 2 on the previous page.

- 1) Unwind the longer length of 1/8" copper tubing and straighten it out.
- 2) Feed the tubing into the left side of the unit and through to the other side.
- 3) Locate the 90° Swagelok fitting (A) on the right end of the upper drain assembly.



### **3.8.3 Internal Drain Line Connections (cont.)**

- 4) Place a 90° bend in the tubing about an 1-1/2" from the end of the tubing (B) for a vertical connection to this fitting.
- 5) Remove the 1/8" nut and ferrule from the Swagelok fitting.
- 6) Slide the nut and ferrule on the tubing and tighten the tubing to this fitting with a 7/16" wrench.
- 7) Make another 90° bend, this time to position the drain line along the *back* side of the front panel, clearing the valve motor.
- 8) Bend the tubing 90° again, for a vertical position down the left side of the front panel (C).
- 9) Look for the Swagelok fitting on the left end of the lower drain assembly (D).
- 10) Make another 90° bend in the tubing about an inch below the valve oven floor (E), directing the tubing towards that fitting on the lower drain assembly.
- 11) Remove the 1/8" nut and ferrule from the connector coming straight out from the drain assembly (D).
- 12) Slide the nut and ferrule onto the tubing and tighten the tubing to this fitting with a 7/16" wrench.
- 13) Remove the 1/8" nut and ferrule from the other connector (F).
- 14) Take the shorter length of tubing, slide the nut and ferrule on, and tighten the tubing to this fitting with a 7/16" wrench.
- 15) Carefully bend this tubing down to the drain outlet (G) on the back of the rear panel.
- 16) Slide the 1/8" nut and ferrule (in the kit box) onto the other end of the tubing and connect this fitting to the drain outlet with a 7/16" wrench.

### 3 CONNECTING ALS 2016 TO LSC 2000

#### 3.8.4 Electronic Connections

- 1) Straighten out the wire bundle from the upper drain assembly.
- 2) Find the wire clips along the right edge (inside) of the unit and fasten the bundle down.
- 3) Carefully attach the upper drain assembly connector to the ten pin receptacle on the left side of the Mother Board, labeled DRAIN VALVES 1-8.

**NOTE:** Install the connector so that the polarizing lip locks into place.

- 4) Carefully attach the connector from the lower drain assembly to the ten pin receptacle on the right side of the Mother Board, labeled DRAIN VALVES 9-16.

**NOTE:** Install the connector so that the polarizing lip locks into place.

#### 3.8.5 Leak Checking Automatic Drain Assembly

- 1) Before installing the white compartment cover, plug both units into a power source.
- 2) Install glassware on the #1 sample valve assembly and fill with blank water.
- 3) Turn the drain handle 180° (opposite) away from the Teflon® drain line connection to operate the automatic drain system.
- 4) The automatic drain assembly must be programmed through the microprocessor. Follow the instructions in your LSC 2000 User Manual to turn the drain assembly on.
- 5) Run the sample, check for internal leaks during the drain mode, and tighten fittings where necessary.
- 6) Unplug both units and reinstall the white compartment cover with the ten 1/4 turn screws.
- 7) Reinstall the glassware and leak check according to Section 3.7. Check all 16 sample valve drain lines for leaks and finger tighten where needed.

Before you begin:

**\*\* IMPORTANT \*\***

If you are installing all three units (LSC 2000, ALS 2016 and ALS 2032) at the *same time*, go to the directions in Section 5.

**4.1  
General**

This section contains instructions for connecting an ALS 2032 to an existing LSC 2000/ALS 2016 system. Please note that the ALS 2032 can operate independent of the ALS 2016 and can be connected directly to the LSC 2000. The BCD output will recognize the samples as #17 to #32. Follow the instructions in Section 3, installing the ALS 2032 instead of the ALS 2016.

This section is intended to be as thorough as possible. However, certain specific items will vary depending on the make and model of the gas chromatograph used. If in doubt on any point, please contact our Service Department toll free at (800) 874-2004, and locally or outside the U.S. at (513) 761-0633 for assistance. When installation is not performed or directed by Tekmar personnel, the operator must be thoroughly familiar with this section before proceeding.

**4.2  
Site  
Preparations**

***The ALS 2016 and ALS 2032 can be placed on either side of the LSC 2000 with the ALS 2032 between the other two.*** Transfer line bundles are attached to the rear panels of the ALS 2032 by cable ties. Cut the ties and uncoil the lines. Turn off the LSC 2000 and the ALS 2016, remove the power cords, and allow the heated valve and lines to cool before beginning.

**4.3  
Power  
Requirements**

The power source required is 50 or 60 Hz, single phase at 120V or 220V  $\pm$  10%. The maximum current draw is 6 amps for the ALS 2016 and 7 amps for the ALS 2032 (110V). Maximum power consumption is 720 watts for the ALS 2016 and 840 watts for the ALS 2032. The AC power cord is terminated with a 3-prong straight blade plug and requires a matching receptacle.

3000  
SN 95026004

## **4** *CONNECTING ALS 2032 TO LSC 2000/ALS 2016*

### **4.4 Purge Gas and Sample Connections from ALS 2032 to LSC 2000**

Refer to Figure 1 in this section and the LSC 2000 & ALS 2016 Flow Diagram in the back of the manual.

- 1) Be sure that the LSC 2000 and ALS 2016 are off, the power cords have been removed, and the lines are cool.
- 2) Remove the trap compartment cover panel by loosening the two 1/4 turn screws and pulling the panel towards the front of the instrument.
- 3) Remove the left side panel cover by loosening four 1/4 turn phillips head screws and sliding the panel back about one inch.
- 4) Remove the valve oven cover by removing two truss head screws and loosening the two 1/4 turn phillips head screws.
- 5) Pull the valve heater block off the valve and move it away to get to the transfer line connections.
- 6) To remove the rear compartment cover panel of the ALS 2032, loosen the ten 1/4 turn screws (4 on each side, 2 on the back) and pull the panel towards you, away from the instrument. Remove the six 1/4 turn screws from the inside compartment cover and pull this cover towards you, away from the instrument.
- 7) Disconnect the ALS 2016 sample line from the gold-plated sample tee in the LSC 2000 valve oven.
- 8) Disconnect the ALS 2016 purge line at the Swagelok union coming from the dry purge valve in the LSC 2000. This union is located near the front of the valve oven.
- 9) Remove the ALS 2016 transfer line from the LSC 2000.
- 10) Feed the ALS 2016 transfer line through the opening in the rear panel of the ALS 2032, keeping it to the left of the ALS 2032 transfer line.
- 11) Cut the Swagelok fitting off the ALS 2016 purge line and replace it with the short Valco nut (#14-0243-016) and ferrule (#14-0241-016) provided in the kit box.

#### 4.4 Purge Gas Connection From ALS 2032 to LSC 2000 (cont.)

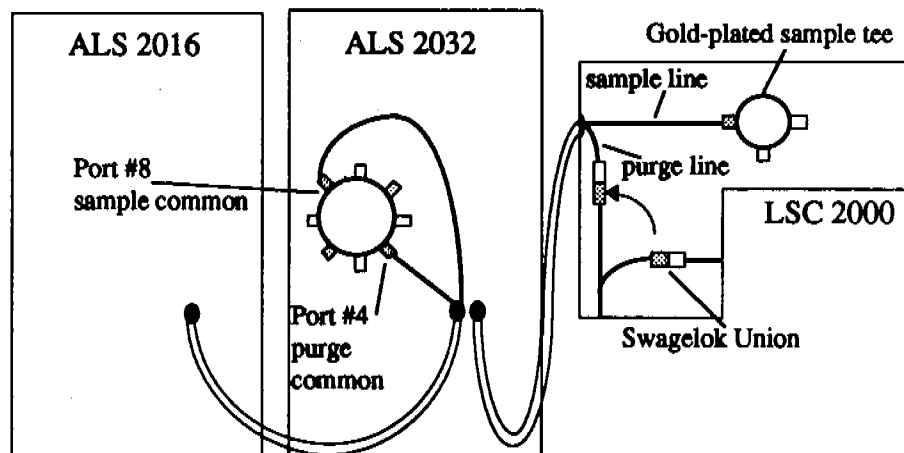

Figure 1

- 12) Connect the ALS 2016 sample line to port #8 on the 8 port switching valve in the ALS 2032 (see the ALS 2016/ALS 2032 Flow Diagram in the back of the manual.).
  - 13) Connect the ALS 2016 purge line to port #4 of the 8 port switching valve in the ALS 2032.
  - 14) The ALS 2032 transfer line bundle contains a purge line with a Swagelok nut and a sample line with a Valco nut. Slide the bundle through the hole in the rear panel of the LSC 2000 labeled FROM ALS (next to the heated transfer line to the GC).
  - 15) Connect the ALS 2032 purge line to the Swagelok union coming from the dry purge valve in the LSC 2000.
  - 16) Connect the ALS 2032 sample line to the gold-plated sample tee.
- NOTE:** The other side of the gold-plated sample tee contains glass lined tubing. Care should be taken while installing the sample common line to prevent fracturing the glass-lined tubing.
- 17) Continue through Sections 4.5-4.7 before reinstalling the valve heater block and all the covers, because you will need to leak check all the internal fittings. Leak checking is described in Section 4.7.

## 4 CONNECTING ALS 2032 TO LSC 2000/ALS 2016

### 4.5 Electronic Interconnection to LSC 2000

The ALS 2016 and ALS 2032 Logic Boards must be installed in the LSC 2000 Electronics Module. They may occupy any available card slot other than the two outermost card slots which are reserved for the Power Supply Board and the LSC 2000 Logic Board.

- 1) Turn off and unplug the LSC 2000.
- 2) Remove two card slot covers and insert the ALS 2016 and ALS 2032 Logic Boards until they are fully seated in the connectors (they will be flush with all other card slot covers).
- 3) Tighten the screw connectors to secure the boards.
- 4) Connect one end of the two 37 pin D-type Logic Cable connectors to the ALS 2016 and ALS 2032 Logic Boards.
- 5) Connect the other end of the cables to the rear of the ALS 2016 and ALS 2032 at the 37 pin D- type connectors.
- 6) Plug in the main power cords for the LSC 2000, ALS 2016, and ALS 2032 and power up both instruments.

### 4.5.1 Interconnection to Gas Chromatograph

To operate fully automatically, the LSC 2000 must be wired to start the GC and data system, and to accept a ready signal from the GC. Refer to the GC Interface Cable Installation Instructions which accompany the cable.

### 4.6 Sampler Connections

Please review the instructions below for 1/2" glassware connections and refer to the ALS 2016 Front View diagram in the back of the manual. The lines for the purge and the sample sides of the glassware are preassembled. The sample valve and needles are unassembled when shipped. For installing 3/4" glassware kits, refer to Section 9.2.

### 4.6.1 Purge Lines

Refer to the ALS 2016 Front View diagram in the back of the manual.

- 1) Connect nickel purge lines to each of the front panel purge bulkheads.

**NOTE:** a) The top row of purge lines coils to the left of the purge bulkhead.  
b) The bottom row coils to the right of the purge bulkhead.

## 4.6.2 Sample Valves

The sample valve assemblies and needles are not connected when shipped.

- 1) Insert a needle into the bottom of each black sample valve. Take care not to lose the Teflon® ferrules and nuts on the needle.

**NOTE:** a) The top row valves have an additional port on the right.  
b) The bottom row valves have an additional port on the left.

- 2) Slide the nut (with the 2 piece ferrule inside) up and screw it onto the Sample valve to secure the needle.
- 3) Insert each assembly into each position slot on the front of the unit.

## 4.6.3 Fritted/Fritless Disc Spargers and Needle Spargers

- 1) Grasp the glassware so that it is held by the end of the purge gas inlet.
- 2) Place the 1/2" sample nut and ferrule over the sample inlet side of the glassware.
- 3) Slide the glassware up over the needle and insert into the sample mount until the glassware seats in the fitting.
- 4) Withdraw the glassware 1-2 mm and finger tighten. Failure to set this clearance may result in breakage of the glassware.
- 5) Adjust the height of the sample needle so that it is about 1-2 mm above the surface of the frit in a frit sparger sampler or above the bottom of the vessel in a needle sparge sampler.
- 6) Tighten the 1/16" nut at the top of the sample mount. This should be finger tight only because it contains a Teflon® ferrule.
- 7) Connect the 1/4" fitting on the nickel purge line to the purge inlet side of the glassware and finger tighten the nut.
- 8) Leak check according to Section 4.7.

## 4 CONNECTING ALS 2032 TO LSC 2000/ALS 2016

### 4.6.4 Drain Lines

If equipped with the automatic drain, the 1/16" Teflon® lines will pass through the front panel immediately adjacent to the sample valves. Connect these lines to the side port of the sample valve.

### 4.7 Leak Checking

The LSC 2000/ALS 2016/ALS 2032 is not a leak prone system, however, it is very leak sensitive. Utmost care should be taken to ensure that the system is leak tight. All fittings should be thoroughly leak checked.

The simplest and most effective way to leak check a system is by bubble leak check.

To begin a complete leak check, place a 1/16" Swagelok cap nut (included) on the LSC 2000 vent fitting and tighten it wrench tight.

**CAUTION:** Do NOT use any type of soap solution (e.g., Snoop or Detect) to leak check. If these solutions get into the lines, increased background and adsorption are likely to occur.

Leak checking is best accomplished with an electronic thermal conductivity detector.

**NOTE:** Electronic leak detectors do not work well when using nitrogen as the purge gas. If possible, use helium when leak checking.

If an electronic leak detector is not available, a 1:1 solution of isopropanol:water may be used, if done so sparingly.

Complete the following steps for each individual glassware:

- 1) Put 5ml of organic-free water in the purge vessel.
- 2) Press STEP to advance the unit to Purge mode.
- 3) Press HOLD to keep the system in Purge mode. This procedure causes the system to pressurize.
- 4) Time the bubbling in the purge vessel. If the bubbling stops between 3 to 7 minutes, the system is leak tight and no further leak checking is necessary.



## 4.7 Leak Checking (cont.)

### TO DIAGNOSE:

First make sure the leak is not at the capped vent. The Swagelok nut may be worn out.

- a) If the bubbling stops before 3 minutes have elapsed, it is likely that there is a leak upstream of the purge vessel (before the gas flow reaches the purge vessel). If a leak is indicated, leave the system in purge with the cap on the vent. Capping the vent causes an increase in pressure which will exaggerate the leak and make it easier to find.
- b) If the bubbling continues after 7 minutes, a leak downstream of the purge vessel is indicated (after the gas flow leaves the purge vessel).
- 5) Remove the trap cover at the front left side of the LSC 2000. Check the fittings at the top and the bottom of the trap.
- 6) Check the 10 fittings inside the valve oven of the LSC 2000. Take note to check the two connections that you just made to the LSC 2000 from the ALS 2032.
- 7) Remove the rear compartment cover panels of the ALS 2016 and ALS 2032.
- 8) Check the following 5 fittings around the glassware on the front of the ALS 2016 and ALS 2032 (See ALS 2016 & ALS 2032 Flow Diagram in the back of the manual):
  - a. purge line fitting (at glassware)
  - b. purge bulkhead (at unit)
  - c. sample glassware fitting
  - d. sample needle nut
  - e. sample valve (3 port)
- 9) Check the purge bulkhead and the sample bulkhead fittings on the inside of the front panel of the ALS 2016 and ALS 2032.
- 10) Check the 18 Swagelok fittings inside the LSC 2000. (See the LSC 2000 Leak Check diagram in the LSC 2000 User Manual).

## **4** *CONNECTING ALS 2032 TO LSC 2000/ALS 2016*

### **4.7 Leak Checking (cont.)**

- 11) Leak check each sample position in the ALS 2016 and ALS 2032.
- 12) Reinstall the valve heater block on the valve in the LSC 2000. Replace the valve oven cover first, left side panel next, and then the trap cover.

If you have trouble locating a leak, please contact our Service Department for assistance at (800) 874-2004 and locally or outside the U.S. at (513) 247-7000.

**SECTION 5**  
**COMPLETE SYSTEM INSTALLATION**  
**LSC 2000/ALS 2016/ALS 2032**

---



*Before you begin:*

If you are installing an ALS 2016 to a LSC 2000, follow the instructions in Section 3. If you are connecting an ALS 2032 to an existing LSC 2000/ALS 2016 system, follow the directions in Section 4.

## 5.1 General

This section contains instructions for a complete LSC 2000, ALS 2016, and ALS 2032 installation. Please note in Section 4 that the ALS 2032 can operate independent of the ALS 2016.

This section is intended to be as thorough as possible. However, certain specific items will vary depending on the make and model of the gas chromatograph used. If in doubt on any point, please contact our Service Department toll free at (800) 874-2004, and locally or outside the U.S. at 761-0633 for assistance. When installation is not performed or directed by Tekmar personnel, the operator must be thoroughly familiar with this section before proceeding.

## 5.2 Site Preparations

***The ALS 2016 and ALS 2032 can be placed on either side of the LSC 2000 with the ALS 2032 in the middle.*** Before connecting these three units, you must follow through with the instructions in Section 2 and Section 3 of your LSC 2000 User Manual to install the LSC 2000. The transfer line bundles of the ALS 2016 and the ALS 2032 are attached to their rear panels by cable ties. Cut the ties and uncoil the lines.

## 5.3 Power Requirements

The power source required is 50 or 60 Hz, single phase at 120V or 220V  $\pm$  10%. The maximum current draw is 6 amps for the ALS 2016 and 7 amps for the ALS 2032 (110V). Maximum power consumption is 720 watts for the ALS 2016 and 840 watts for the ALS 2032. The AC power cord is terminated with a 3-prong straight blade plug and requires a matching receptacle.

## 5.4 Purge Gas and Sample Connections from ALS 2016 to ALS 2032 to LSC 2000

Refer to Figure 1 on the following page, and the LSC 2000 & ALS 2016 Flow Diagram and ALS 2016/ALS 2032 Flow Diagram in the back of the manual.

- 1) Remove the trap compartment cover panel of the LSC 2000 by loosening the two 1/4 turn screws and pulling the panel towards the front of the instrument.
- 2) Remove the left side panel cover by loosening four 1/4 turn phillips head screws and slide the panel back about one inch.

## 5 COMPLETE SYSTEM INSTALLATION LSC 2000/ALS 2016/ALS 2032

### 5.4 Purge Gas and Sample Connections from ALS 2016 to ALS 2032 to LSC 2000 (cont.)

- 3) Remove the valve oven cover by removing two truss head screws and loosening the two 1/4 turn phillips head screws.
- 4) Pull the valve heater block off the valve and move it away to get to the transfer line connections.
- 5) Remove the rear compartment cover panel of the ALS 2032 by loosening the ten 1/4 turn screws (4 on each side, 2 on the back) and pull the panel away from the instrument. Remove the six 1/4 turn screws from the inside compartment cover and pull this cover towards you, away from the instrument.
- 6) Feed the ALS 2016 transfer line through the opening in the rear panel of the ALS 2032, keeping it to the left of the ALS 2032 transfer line.
- 7) Connect the ALS 2016 sample line to port #8 on the 8 port switching valve in the ALS 2032.
- 8) Cut the Swagelok fitting off the ALS 2016 purge line and replace it with the short Valco nut (#14-0243-016) and ferrule (#14-0241-016) provided in the kit box.
- 9) Connect the ALS 2016 purge line to port #4 of the 8 port switching valve in the ALS 2032.

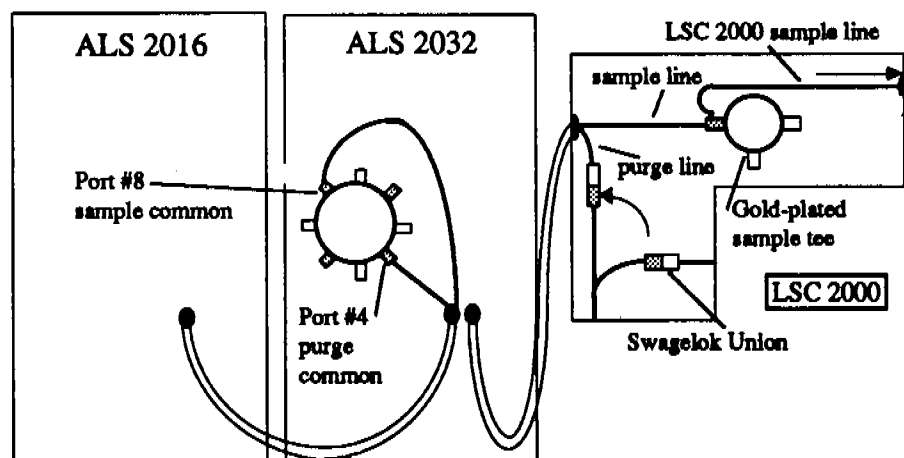

Figure 1

**5.4  
Purge Gas and  
Sample  
Connections  
from ALS 2016  
to ALS 2032 to  
LSC 2000  
(cont.)**

- 10) The ALS 2032 transfer line bundle contains a purge line with a Swagelok nut and a sample line with a Valco nut. Slide the bundle through the hole in the rear panel of the LSC 2000 labeled FROM ALS (next to the heated transfer line to the GC).
- 11) Unfasten the LSC 2000 sample line (glass-lined tubing) at the sample mount fitting on the front of the unit and on the left side of the gold-plated sample tee inside the valve oven.
- 12) Carefully back the line through the front panel into the valve oven area.
- 13) Remove the line from the instrument and store it in a safe place.
- 14) Disconnect the LSC 2000 purge line from the 1/16" Swagelok union near the front of the valve oven.
- 15) Connect the ALS 2032 purge line to that Swagelok union.
- 16) Connect the ALS 2032 sample line to the gold-plated sample tee.

**NOTE:** The other side of the gold-plated tee contains glass lined tubing. Care should be taken while installing the sample line to prevent fracturing the glass lined tubing.

- 17) Continue through Sections 5.5-5.7 before reinstalling the valve heater block and all the covers, because you will need to leak check internal fittings. Leak checking is described in Section 5.7.

**5.5  
Electronic  
Interconnection  
to LSC 2000**

The ALS 2016 and ALS 2032 Logic Boards must be installed in the LSC 2000 Electronics Module. They may occupy any available card slot other than the two outermost card slots which are reserved for the Power Supply Board and the LSC 2000 Logic Board.

- 1) Turn off and unplug the LSC 2000.

## 5 COMPLETE SYSTEM INSTALLATION LSC 2000/ALS 2016/ALS 2032

### 5.5 Electronic Interconnection to LSC 2000 (cont.)

- 2) Remove two of the card slot covers and insert the ALS 2016 and ALS 2032 Logic Boards until they are fully seated in the connectors (they will be flush with all other card slot covers).
- 3) Tighten the screw connectors to secure the boards.
- 4) Connect one end of the two 37 pin D-type Logic Cable connectors to the ALS 2016 and ALS 2032 Logic Boards.
- 5) Connect the other ends of the cables to the rear of the ALS 2016 and ALS 2032 at the 37 pin D-type connectors (See the ALS 2016 Rear View diagram in the back of the manual).
- 6) Plug in the main power cords for the LSC 2000, ALS 2016, and ALS 2032 and power up all instruments.

### 5.5.1 Interconnection to Gas Chromatograph

To operate fully automatically, the LSC 2000 must be electronically interfaced to start the GC and data system, and to accept a ready signal from the GC. Refer to the GC Interface Cable Installation Instructions which accompany the cable.

### 5.6 Sampler Connections

Please review the instructions below for 1/2" glassware connections and refer to the ALS 2016 Front View diagram in the back of the manual. The lines for the purge and the sample sides of the glassware are preassembled. The sample valve and needles are unassembled when shipped. For installing 3/4" glassware kits, refer to Section 9.2.

### 5.6.1 Purge Lines

Refer to the ALS 2016 Front View diagram in the back of the manual.

- 1) Connect nickel purge lines to each of the front panel purge bulkheads.

**NOTE:** a) The top row of purge lines coils to the left of the purge bulkhead.  
b) The bottom row coils to the right of the purge bulkhead.



## 5.6.2 Sample Valves

The sample valve assemblies and needles are not connected when shipped.

- 1) Insert a needle into the bottom of each black sample valve. Take care not to lose the Teflon® ferrules and nuts on the needle.

**NOTE:** a) The top row valves have an additional port on the right.

- b) The bottom row valves have an additional port on the left.

## 5.6.3 Fritted/Fritless Disc Spargers and Needle Spargers

Refer to the ALS 2016 Front View diagram in the back of the manual.

- 1) Grasp the glassware so that it is held by the end of the purge gas inlet.
- 2) Place the 1/2" sample nut and ferrule over the sample inlet side of the glassware.
- 3) Slide the glassware up over the needle and insert into the sample mount until the glassware seats in the fitting.
- 4) Withdraw the glassware 1-2 mm and finger tighten. Failure to set this clearance will result in breakage of the glassware.
- 5) Adjust the height of the sample needle so that it is about 1-2 mm above the surface of the frit in a frit sparger sampler or above the bottom of the vessel in a needle sparge sampler.
- 6) Tighten the 1/16" nut at the top of the sample mount. This should be finger tight only because it contains a Teflon® ferrule.
- 7) Connect the 1/4" fitting on the nickel purge line to the purge inlet side of the glassware and finger tighten the nut.
- 8) Leak check according to Section 5.7.

## 5.6.4 Drain Lines

If equipped with the automatic drain, the 1/16" Teflon® lines will pass through the front panel immediately adjacent to the sample valves. Connect these lines to the side port of the sample valve.

**5.7  
Leak Checking**

The LSC 2000/ALS 2016/ALS 2032 is not a leak prone system, however, it is very leak sensitive. Utmost care should be taken to ensure that the system is leak tight. All fittings should be thoroughly leak checked.

The simplest and most effective way to leak check a system is by bubble leak check.

To begin a complete leak check, place a 1/16" Swagelok cap nut (in the kit box) on the LSC 2000 vent fitting and tighten it wrench tight.

**CAUTION:** Do NOT use any type of soap solution (e.g. Snoop or Detect) to leak check. If these solutions get into the lines, increased background and adsorption are likely to occur.

Leak checking is best accomplished with an electronic thermal conductivity detector.

**NOTE:** Electronic leak detectors do not work well when using nitrogen as the purge gas. If possible, use helium when leak checking.

If an electronic leak detector is not available, a 1:1 solution of isopropanol:water may be used, if done so sparingly.

Complete the following steps for each individual glassware:

- 1) Put 5ml of organic-free water in the purge vessel.
- 2) Press STEP to advance the unit to Purge mode.
- 3) Press HOLD to keep the system in Purge mode. This procedure causes the system to pressurize.
- 4) Time the bubbling in the purge vessel. If the bubbling stops between 3 to 7 minutes, the system is leak tight and no further leak checking is necessary.

## 5.7 Leak Checking (cont.)

### TO DIAGNOSE A LEAK:

First make sure the leak is not at the capped vent. The Swagelok nut may be worn out.

- a) If the bubbling stops before 3 minutes have elapsed, it is likely that there is a leak upstream of the purge vessel (before the gas flow reaches the purge vessel). If a leak is indicated, leave the system in purge with the cap on the vent. Capping the vent causes an increase in pressure which will exaggerate the leak and make it easier to find.
- b) If the bubbling continues after 7 minutes, a leak downstream of the purge vessel is indicated (after the gas flow leaves the purge vessel).
- 5) Remove the trap cover at the front left side of the LSC 2000. Check the fittings at the top and the bottom of the trap.
- 6) Take note to check the two connections that you just made to the LSC 2000 from the ALS 2032.
- 7) Remove the rear compartment cover panels of the ALS 2016 and the ALS 2032.
- 8) Check the 5 fittings around the glassware on the front of the ALS 2016 and ALS 2032 (See the ALS 2016 Front View diagram in the back of the manual).
  - a. purge line fitting (at glassware)
  - b. purge bulkhead (at unit)
  - c. sample glassware fitting
  - d. sample needle nut
  - e. sample valve (3 port)
- 9) Check the purge bulkhead and the sample bulkhead fittings on the inside of the front panel of the ALS 2016 and ALS 2032 (See the ALS 2016 Upper Right View diagram in Section 11).
- 10) Check the 18 Swagelok fittings inside the LSC 2000 (See the LSC 2000 Leak Check Diagram in the LSC 2000 User Manual).

## **5** COMPLETE SYSTEM INSTALLATION LSC 2000/ALS 2016/ALS 2032

### **5.7 Leak Checking (cont.)**

11) Leak check each sample position in the ALS 2016 and ALS 2032.

12) Reinstall the valve heater block on the valve in the LSC 2000. Replace the valve oven cover first, left side panel next, and then the trap cover.

If you have trouble locating a leak, please contact our Service Department for assistance at (800) 874-2004, and locally or outside the U.S. at (513) 247-7000.

**SECTION 6**  
**ROUTINE OPERATING PROCEDURES**



6.1  
Sample  
Loading

Samples can be loaded in two ways:

- a) Remove the glassware, insert the sample, and reinstall the glassware.
- b) Use a luer-lock syringe to load the sample through the sample valve.

Loading through the sample valve should be performed only with aqueous samples.

**NOTE:** a) Solids are generally weighed in the glassware.  
b) Liquids are usually loaded from a syringe.

- 1) Reinstall the glassware to the instrument.
- 2) When loading through the sample valve, point the handle towards the instrument, opposite the female luer.
- 3) To run with an automatic drain, point the handle 180° away from the drain line.
- 4) To run without the drain, turn the handle 180° from a solid side (no port side) of the valve.

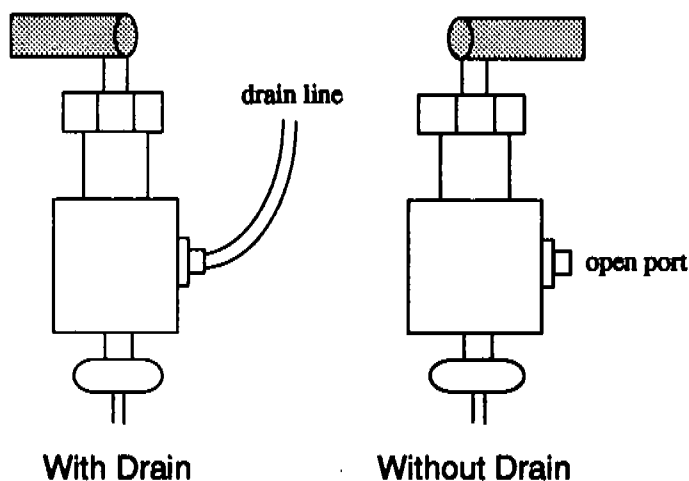

## **6 ROUTINE OPERATING PROCEDURES**

### **6.1.1 Syringe Handling Technique**

Proper syringe technique is vital to a successful analysis. Do not load samples by drawing them up into the syringe. This creates a vacuum headspace which can seriously degrade sample integrity. To load a sample:

- 1) Remove the plunger from the syringe barrel.
- 2) Carefully pour the sample into the barrel until it overflows. A syringe valve should be used to permit the syringe to remain filled.
- 3) Insert the plunger and adjust to the desired volume. Take care to vent any residual air while adjusting the volume.

### **6.2 Control Sequence**

- 1) Set all operating parameters on the LSC 2000 for both the ALS 2016 and ALS 2032. (See Section 7.4).
- 2) When PURGE READY mode is reached, load the first sample.
- 3) Press the START switch. Purging should begin immediately.
- 4) Load the remainder of the samples.
- 5) When purging of the first sample is complete, the LSC 2000 will hold at DESORB READY until it receives the ready signal from the GC.
- 6) The LSC 2000 will then proceed to DESORB PREHEAT and DESORB, and will start the GC and data system.
- 7) After DESORB and BAKE, the LSC 2000 will advance to STANDBY.
- 8) When the trap is cool, the LSC 2000 advances to PURGE READY.
- 9) The ALS 2016 or ALS 2032 will now advance position and PURGE will begin.



### 6.3 Bake Gas Bypass

Bake Gas Bypass (BGB) is a standard feature of the LSC 2000. The BGB diverts purge gas away from the ALS 2016 and ALS 2032 samplers during the LSC 2000 Trap Bake Cycle. Without BGB, bake gas flows through the sampler whose purge cycle has just completed. If this sample has residual volatiles, the sample transfer line to the LSC 2000 could contain measurable amounts of sample at completion of the Trap Bake Cycle that could be seen in the next sample run. BGB eliminates this possibility and is recommended for applications involving high sample loadings and solid samples such as soils. As a general rule, BGB should be off if samples are drained automatically and on if samples are not drained.

#### **Bake Gas Bypass (BGB) Delay**

The BGB Delay should always be activated when using the sample tubes for liquids or solids. Assigning a 1 minute delay will allow the backpressure in unit to equilibrate before the Bypass valve is turned on. This prevents the sample from being pushed up into the needle and contaminating the 6-port valve and internal lines. See Section 7.4 to configure the BGB Delay.

### 6.4 Sampler Clean-Up

Sampler clean-up (including the sample introduction needle) is one of the most important steps in avoiding contamination.

- a) The glassware should be thoroughly cleaned and dried for each new sample.
- b) The sample introduction needle should be cleaned on a routine basis, the frequency depending upon the nature of the sample. Aqueous samples require infrequent cleaning; oils and other "messy" samples require cleaning after every run.

See Section 9.1, Routine Maintenance for cleaning the system.



SECTION 7

ALS 2016/2032 MICROPROCESSOR CONTROL



## 7.1 General Description

The accessories added to the base unit LSC 2000 are all acknowledged and controlled through the microprocessor of the LSC 2000. The ALS 2016 and the ALS 2032 are shipped with an interface board and an interface cable. The interface board slides into any one of the available expansion slots on the rear of the electronics module of the 2000. The cable connects the ALS 2016 and/or the ALS 2032 to the LSC 2000 at the plug in the interface card of the 2000. See Section 3.5, 4.5, and 5.5, Electronic Interconnection to LSC 2000 in this manual.

## 7.2 Powering Up the System

Upon routine power up, the system conducts self tests to confirm that all its heated components are working properly. Default values are loaded into the RAM of the LSC 2000 from ROM when either Run or Edit is chosen from the Method menu.

## 7.3 Running Self Tests

To conduct self tests the system briefly turns on each heater in succession. When the thermocouple for a particular heater registers a temperature increase of approximately 2°C, the system advances to the next heater. This is a self-diagnostic test for the CPU to make sure the heaters are functioning. **You set the LSC 2000 to acknowledge the ALS 2016 and/or ALS 2032 after this self-test. See Section 7.4, Configuring LSC 2000 to Acknowledge ALS 2016/ALS 2032.** The following screens will be displayed:

Self Test in Progress

Basic LSC

Line: ok

Valve: ok

BOT: ok

Mount: 22°

Trap: ok

Help

Skip

Self Test in Progress

Capillary Interface

Cryo trap: ok

Injector: ok

Help

Skip

# 7 ALS 2016/2032 MICROPROCESSOR CONTROL

## 7.3 Running Self Tests (cont.)

Self Test in Progress  
Sample Heater  
Sample: 22°  
Help Skip

Self Test in Progress  
Aux Heater  
Aux Htr: 21°  
Help Skip

Self Test in Progress  
ALS 2016  
Valve: ok  
Line: 22°  
Help Skip

Self Test in Progress  
ALS 2016 Sample Heater  
Sample: 22°  
Help Skip

Self Test in Progress  
ALS 2032  
Valve: ok                      Line: ok  
Valve: ok  
Help Skip

Self Test in Progress  
ALS 2032 Sample Heater  
Sample: 22°  
Help Skip

F1

F2

F3

F4

7.3  
Running Self  
Tests (cont.)

Self tests may be skipped at any time (press F4 (Skip)). This will cause the system to advance and test the next heater. However, the system acknowledges skipping a self test as a failure.

```

FAILURE
Basic LSC
Line: ok   Valve: ok
BOT: ok   Mount: ok
Trap: ok
Help           Ignore       Retest
    
```

Press F3 (Ignore) to acknowledge that the test was purposefully skipped.

**IMPORTANT:** If an error message appears for a heater that was not skipped, press F4 (Retest) to rerun the self tests on that set of heaters.

**NOTE:** If an ALS 2032 or a Capillary Interface are not installed, the tests for these accessories must be manually skipped.

**IMPORTANT:** Do not skip the self tests for the ALS 2016 or the ALS 2032 if you wish to use them. The microprocessor will fail to recognize their presence when you try to install them.

When the self tests are complete the system goes to the Current Configuration screen. The ALS 2016/ALS 2032 are now ready to be acknowledged by the LSC 2000 .

```

Current Configuration           VX.XX
Date: 4/15/99                   Time: 12:30:00
Baud: 1200  ALS 2016: N        ALS 2032: N
(PAGE DOWN for more)
Help           LSC           Inst           OK
    
```



## 7 ALS 2016/2032 MICROPROCESSOR CONTROL

### 7.4 Configuring LSC 2000 to Acknowledge ALS 2016 and/ or ALS 2032

The LSC 2000 must be configured to acknowledge the ALS 2016 and/or the ALS 2032.

- 1) From the Start Up screen press **F4 (Conf)** to display the Current Configuration screen. During execution of any program node, pressing **F4 (Conf)** will display the Current Configuration screen.

Start Up	Method 1	ALS 15
Line: 80° > 100	Valve:	80° > 100
BOT: 75° > 100	Capillary	
Mount: 35° > 40	Int: 99° > 100	
Meth ALS	Temp Conf	

Current Configuration	VX.XX
Date: 4/15/99	Time: 12:30:00
Baud: 1200 ALS 2016: N	ALS 2032: N
(PAGE DOWN for more)	
Help LSC Inst	OK

- 2) Press **F3 (Inst)** to access the Accessories screen:

ALS 2016: Y	
2016 Heater:	not installed
ALS 2032: Y	
2032 Heater:	not installed
(PAGE DOWN for more)	
Help <- ->	Exit

Pressing **PAGE DOWN** on the keypad displays the rest of the accessories available:

Capillary Interface: ■	
Sample Heater: N	
Aux. Heater: N	
(PAGE UP for more)	
Help <- ->	Exit



## 7.4 Configuring LSC 2000 to Acknowledge ALS 2016 and/or ALS 2032 (cont.)

- 4) To configure the ALS 2016 and/or ALS 2032, press **F2** (←) or **F3** (→) to move the highlighted box to the desired instrument.
- 5) Press **Y** (digit 7) or **N** (digit 9) to acknowledge the instrument (or to turn it off). Press **PAGE DOWN/UP** to display the other accessories.

**NOTE:** If an accessory is not configured it cannot be turned on (activated). If the self tests for an accessory were skipped, that accessory will not be activated.

- 6) When all instruments you need are configured, press **F4** (Exit) to return to the Current Configuration screen.

Current Configuration	VX.XX
Date: 5/15/99	Time: 12:30:00
Baud: 1200 ALS 2016: Y	ALS 2032: Y
(PAGE DOWN for more)	
Help	LSC
Inst.	OK

### When Using Sample Tubes Instead of Spargers

If you are using sample tubes to run samples you *must* configure the Bake Gas Bypass (BGB) Delay (ROM version 1.7 or greater. Check the upper right corner of the Configuration screen).

- 1) Press **F4** (OK) to return to the Start Up screen.
- 2) Press **F1** (Meth), activate the Method desired, press **F4** (Exit), then **F4** (Edit) for the Method Parameter screen.
- 3) Press **PAGE DOWN** to view the Bake Gas Bypass parameters.
- 4) Move the highlighted box to the Bake Gas Bypass parameter and press **ENTER**.
- 5) Press **F1** (ON) to turn the Bake Gas Bypass on and press **F4** (Exit).
- 6) Highlight the Bake Gas Bypass Delay parameter and enter 60 seconds and press **F4** (Exit) to return to the Start Up screen.

You are now ready to set the start and stop positions for Method Scheduling (running sets of samples with different methods). See Section 7.7 to learn how to apply Method Scheduling to your runs.

### 7.5 Setting Sample Start and Stop Positions

When running an ALS 2016 and/or 2032 the start and stop positions must be entered into the memory of the microprocessor to acknowledge the different "sets" of runs. These methods will be set in Method Scheduling, Section 7.7.

Start Up	Method 1	ALS 15
Line: 80° > 100	Valve: 80° > 100	
BOT: 75° > 100	Capillary	
Mount: 35° > 40	Int: 99° > 100	
Meth ALS	Temp	Conf

1) Press **F2 (ALS)** to view the Automatic Sampler Control screen.

Automatic Sampler Control			
32 positions available			
Current position: 4			
Start: 1	Stop:	<input type="checkbox"/>	
Enable method schedule: Y			
Help	Sched	->	Exit

The total number of sample positions available are displayed, as well as the current sampler position. See Section 7.6, Stepping the Multi-Position Valve to change sampler positions.

2) Use **F3 (->)** or **Backspace (<-)** to move the highlighted box to the Start position. Press **ENTER** to view the individual menu for the Start position.

3) Press the number of the sample position that you wish to begin with, and press **ENTER** again. Move the cursor to the Stop position and repeat this procedure to set the Stop position.

### 7.6 Stepping the Multi-Position Valve

Beginning at the Start Up screen (or when **F2** corresponds to **ALS** on the screen), press **F2 (ALS)** to get to the Automatic Sampler Control screen. Press **STEP** to position the valve to the next sampler, indexing the multi-position valve sequentially.

## 7.7 Using Method Scheduling

The LSC 2000 can be programmed to run four different methods and "schedule" them to run on the ALS 2016 and ALS 2032. This is called Method Scheduling and enables the operator to run "sets" of samples. These sets of samples must be grouped sequentially. For example, samples 1-6 would be run under Method 1, samples 7-10 under Method 2, Samples 11-32 with Method 3, etc., in *automatic succession*. If you are running all your samples by one method then you do not need to use Method Scheduling. Skip to Section 7.8, Running Samples.

Before the unit can be programmed to perform Method Scheduling, check to make sure:

- 1) The ALS 2016 and/or ALS 2032 is installed electronically (i.e., the interface board and cable are connected between the LSC 2000 and the ALS(s).
- 2) The LSC 2000 is configured so that each accessory installed reads "Y" when you view the Current Configuration Screen. The "Y" response means that the accessory is turned on.
- 3) The Method parameters are set to those you wish to use. The guide contained in Section 4.5.1 of your LSC 2000 User Manual will aid you with setting these values.

When accessories are acknowledged to the system, the screen displays the information about those accessories. When the ALS 2016 and/or ALS 2032 is installed, the Start Up screen displays the Method number and sample position being run.

<b>Start Up</b>		<b>Method 1 ALS 15</b>	
Line: 80° > 100		Valve: 80° > 100	
BOT: 75° > 100		Capillary	
Mount: 35° > 40		Int: 99° > 100	
<b>Meth</b>	<b>ALS</b>	<b>Temp</b>	<b>Conf</b>



## 7 ALS 2016/2032 MICROPROCESSOR CONTROL

### 7.7 Using Method Scheduling (cont.)

Press **F2 (ALS)** to view the Automatic Sampler Control screen.

Automatic Sampler Control			
32 positions available			
Current position: 1			
Start: 1	Stop: 5		
Enable method schedule: <input checked="" type="checkbox"/>			
Help	Sched	->	Exit

**IMPORTANT:** When a sequence is running, **F3 (->)** will appear as **F3 (Cancel)**. If **F3 (Cancel)** is chosen during operation, the current sample run will be completed but subsequent samples in the sequence will not be run.

To program or change the Method Schedule, press **F2 (Sched)**. The Method Schedule will appear:

Enable Method Schedule: Y			
Start: 1	Stop: 8	Method: 1	
Start: 9	Stop: 16	Method: <input checked="" type="checkbox"/>	
Start:	Stop:	Method:	
Start:	Stop:	Method:	
Help	Clear	->	Exit

Press **Y (digit 7)** to enable the Method Schedule. (Press **N (digit 9)** if you wish to disable the Method Schedule.) To change position numbers, highlight the parameter you wish to modify and press **ENTER**. Pressing **ENTER** will present the individual menu for the parameter you have highlighted. Press the sample position number you desire and the system automatically returns you to the Enable Method Schedule screen. When all sample positions are programmed into the system, press **F4 (Exit)** to proceed with running the samples.

**NOTE:** When a sequence is running using Method Scheduling, editing function keys are not displayed.

**7.8  
Running  
Samples**

A set of samples may be run from one to nine times. However, if you wish to use auto drain, you should program it for the last run of a sample or set of samples. For example, Auto Drain may be programmed to be turned off in Method 1 and then be turned on for Method 2.

<b>Standby</b>		<b>Method 1</b>	<b>ALS 15</b>
Trap: 33°		Set: < 30°	
Sample: 21°			
<b>Meth</b>	<b>ALS</b>	<b>Temp</b>	<b>Conf</b>

After Standby, when the unit has met the parameter values set for Method 1, the Purge Ready mode begins and displays trap and sample temperatures for the LSC 2000. The unit pauses at this point until the operator presses **START** on the keypad.

<b>Purge Ready</b>		<b>Method 1</b>	<b>ALS 15</b>
Trap: 29°		Sample: 21°	
Ready to start ALS sequence			
Press <b>START</b> to begin sequence			
<b>Meth</b>	<b>ALS</b>	<b>Temp</b>	<b>Conf</b>

When **START** is pressed, the sequence begins. If the Method Schedule is activated and Method 1 is not the current Method, the system will begin in the Start Up mode and proceed from that point.

<b>Purge Ready</b>		<b>Method 1</b>	<b>ALS 15</b>
Trap: 29°		Sample: 21°	
Positioning ALS			
<b>Meth</b>	<b>ALS</b>	<b>Temp</b>	<b>Conf</b>





**7.8  
Running  
Samples  
(cont.)**

B) You can load future samples before the present run is finished if the sample positions for the next Method Schedule are in succession.

*For example:*

a) If your Method Scheduling is in succession, (e.g. 3-8 followed by 9-16), you can load the samples at any time.

b) If your Method Scheduling is not in succession (e.g., 9-16 followed by 5-12), you must wait for 9-16 to finish and return to the Purge Ready mode. Then samples 5-12 may be loaded for their scheduled run.





*SECTION 8*  
*AUTOMATIC SAMPLER HEATERS*

---



**8.1  
Interlocking  
Automatic  
Sample Heater  
with  
ALS 2016 or  
ALS 2032**

The following instructions may also be used for installing the Automatic Sample Heater to the ALS 2032.

- 1) Turn the ALS 2016 off.
- 2) Remove all interface cables and power cords.
- 3) Remove plumbing connections and glassware from the unit.
- 4) Place the Automatic Sample Heater on a sturdy, stable bench surface next to the ALS 2016, adjacent to the LSC 2000.
- 5) Place the ALS 2016 on top of the Automatic Sample Heater. Align the four mounting studs on the Automatic Sample Heater with the four receiving holes in the ALS 2016 base.
- 6) Push the ALS 2016 forward until the front edge of the ALS 2016 and the Sample Heater unit are almost flush (about 3/8"). The two units should now be interlocked.

**8.2  
Electrical  
Connection to  
ALS 2016 or  
ALS 2032**

- 1) Connect one end of the 25 pin D-Type connector cable to the port labeled Sample Heater Accessory Interface on the rear panel of the ALS 2016.
- 2) Connect the other end of the cable to the port labeled ALS 2016 Sample Heater Accessory Interface on the rear panel of the Automatic Sample Heater.
- 3) Plug the female end of the 3' patch power cord to the port labeled POWER on the rear panel of the Automatic Sample Heater.
- 4) Plug the male end of the same cord to the port labeled Line Voltage Unswitched on the rear panel of the ALS 2016.

## 8 SAMPLE HEATER INSTALLATION

### 8.2 Electrical Connection to ALS 2016 or 2032 (cont.)

- 5) Connect one end of the 32 pin D-type Logic Cable to the output board assembly on the rear of the ALS 2016 and the other end to the ALS 2016 Logic Board on the LSC 2000.
- 6) Plug the main power cord from the ALS 2016 into an appropriate power source (See Section 7.8), and power up both instruments.

### 8.3 Power Requirements

The unit requires a 50 or 60 Hz single phase power source at  $120V \pm 10\%$ . The maximum current draw is 1 amp and maximum power consumption is 120 watts. The 3' patch power cord may be used to plug into the Line Unswitched receptacle on the rear of the ALS 2016. Or you may use an AC power cord terminated with a 3-prong straight blade plug. The 3-prong plug is a safety feature. Do not defeat its purpose by using it with an inappropriate receptacle.

### 8.4 Kit Box Assembly

Each Automatic Sample Heater unit is accompanied with a kit box assembly containing parts needed to install the unit. Check to be sure that all necessary items are included before beginning installation.

### 8.5 Sample Heaters

The ALS 2016 or 2032 can be used with two types of sample heaters: pocket or tube.

Pocket heaters are used on the 1/2" needle sparger glassware, U-shaped frit and fritless sparge glassware and other miscellaneous glassware designs. Pocket heaters are pliable mantle-style heaters.

Tube heaters are used on the 3/4" disposable test tube type glassware and 1/2" 25ml needle sparger glassware. These silicone insulated heaters fit snug against the glassware and provide temperature uniformity.

**Note: Tube heaters require ROM version 1.9 or greater.**

## 8.6 Pocket Heater Installation

Refer to the Pocket Heater Positioning Diagram in the back of the manual.

**Always install the sample heaters on the glassware with the glassware off the unit.**

- 1) Grasp the pocket heater so that the power cable is facing you and the label on the left.
- 2) Slide the glassware into the sample heater with the purge side of the glassware to the right and the sample side to the left
- 3) Position the top of the pocket heater below the foam trap of the sample tube.
- 4) Slide the velcro strap across the top of the pocket heater between the sample and purge sides and attach it to the other side of the pocket heater.
- 5) Raise the sample needle sufficiently to clear the glassware.
- 6) Grasp the glassware by the end of the purge inlet.
- 7) Insert the glassware into the 1/2" sample mount as far as possible, then back it out approximately 1/16". Tighten finger tight. **Failure to back the sampler out could cause the top of the glassware to crack.**
- 8) Lower the sample needle and finger tighten.
- 9) Connect the 1/4" purge line union on the ALS 2016 to the purge inlet of the glassware and finger tighten.
- 10) Check for leaks according to Section 3.3 in the LSC 2000 User Manual. If a position leaks at these fittings, the sample mount wrench supplied with the ALS 2016 may be used to tighten the fitting. Avoid over-tightening, which will break the glassware.
- 11) Configure the LSC 2000 to acknowledge the pocket heater (See Section 8.9).

## 8 SAMPLE HEATER INSTALLATION

### 8.7 Tube Heater Installation

- 1) Grasp the tube heater so that the power cable is facing you.
- 2) Slide the glassware into the tube heater.
- 3) Insert the glassware into the sample mount as far as possible, then back it out approximately 1/16". Fingertighten the sample mount. **Failure to back the sampler out could cause the top of the glassware to crack.**
- 4) Check for leaks according to Section 3.3 in the LSC 2000 User Manual. If a position leaks at these fittings, the sample mount wrench supplied with the ALS 2016 may be used to tighten the fitting. Avoid over-tightening, which will break the glassware.
- 5) Configure the LSC 2000 to acknowledge the tube heater (See Section 8.9).

**Remove the glassware from the ALS 2016 before removing the tube heater.**

### 8.8 Sample Heater Numbering

Make sure the glassware enclosed in the #1 sample heater is installed on the #1 position of the ALS 2016 or installed on the #17 position on the ALS 2032. Continue to install the rest of the sample heaters in numerical order. sample heater numbering is as follows:

2016

Top Row	left to right	1-8
Bottom Row	left to right	9-16

2032

Top Row	left to right	17-24
Bottom Row	left to right	25-32

**8.9  
Configuring  
LSC 2000 to  
Acknowledge  
Sample Heater**

The LSC 2000 microprocessor must be configured to acknowledge the accessories you wish to use on your sample runs.

1) To configure the sample heater into the system, you must push the reset button. This will reinitialize the program and run a self test.

**\*\* IMPORTANT \*\***

Do not skip the self-test for the Automatic Sample Heater. The unit will treat skips as failures and not allow you to configure the accessory units.

2) Press **F4 (Conf)** from the Start Up screen to display the Current Configuration screen:

<b>Start Up</b>	<b>Method 1</b>	<b>ALS 15</b>
Line: 80° > 100	Valve: 80° > 100	
BOT: 75° > 100	Capillary	
Mount: 35° > 40	Int: 99° > 100	
Meth ALS	Temp	Conf

<b>Current Configuration</b>	<b>VX.XX</b>
Date: 5/15/93	Time: 12:30:00
Baud: 1200	ALS 2016: Y ALS 2032: Y
(PAGE DOWN for more)	
Help LSC	Inst. OK

## 8 SAMPLE HEATER INSTALLATION

### 8.9

#### Configuring LSC 2000 to Acknowledge Sample Heater (cont.)

3) Press **F3 (Inst.)** to view the sample heater accessory screen. If your unit has ROM version 1.9, your sample heater accessory screen will look slightly different -- see Section 8.9.1; if your unit has ROM version 2.0, see Section 8.9.2.

```
ALS 2016: Y
2016 Heater: not installed
ALS 2032: Y
2032 Heater: not installed
(PAGE UP for more)
Help          <-          ->          Exit
```

4) Press **F2 (<-)** or **F3 (->)** to move the highlighted box to 2016 Heater or 2032 Heater.

5) Press **Y (digit 7)** or **N (digit 8)** after each unit to activate or deactivate the Sample Heater for that unit.

6) Press **F4 (Exit)** to return to the Start Up screen.

If the sample heaters will not accept a **Y** acknowledgment, they are either not connected to the ALS 2016 or the ALS 2032 or did not pass the self tests.

### 8.9.1

#### Configuring LSC 2000 to Acknowledge Sample Heater (1.9 ROM)

If your unit has ROM version 1.9, you must identify which type of heaters you are using. **ROM version 1.9 can be used with either the pocket heaters or the tube heaters, but you cannot mix the two.** To configure your unit for all pocket heaters, press **N (digit 8)** at the 3/4 inch prompt.

```
ALS 2016: Y
2016 Heater: Y (3/4 inch: N)
ALS 2032: Not installed
2032 Heater:
(PAGE DOWN for more)
Help          <-          ->          Exit
```





## 8 SAMPLE HEATER INSTALLATION

### 8.9.2 Configuring LSC 2000 to Acknowledge Sample Heater (2.0 ROM) (cont.)

At the 3/4 Inch prompt, press ENTER to get the following screen:

```
Current: 0
Minimum: 0           Maximum: 16
3/4 Split: _____
Enter zero for none

(press ENTER for no change )
```

At the 3/4 Split prompt, indicate what type of heaters you are using. If you are using all pocket heaters, press 0. If you are using all tube heaters, press 1. If you are using both types of heaters, type the number (2-16) in which the tube heaters begin. **Remember, when you use both types of heaters, the tube heaters go on the last positions.**

If, for example, you use eight pocket heaters and eight tube heaters, then you install the pocket heaters on positions 1-8 and the tube heaters on positions 9-16.

Press 9 at the 3/4 Split prompt.

```
Current: 0
Minimum: 0           Maximum: 16
3/4 Split: 9
Enter zero for none

(press ENTER for no change )
```

**8.9.2  
Configuring  
LSC 2000 to  
Acknowledge  
Sample Heater  
(2.0 ROM)  
(cont.)**

Pressing **ENTER** brings you back to the sample heater accessory screen, and the location of the tube heaters will be indicated at the 3/4 Inch prompt.

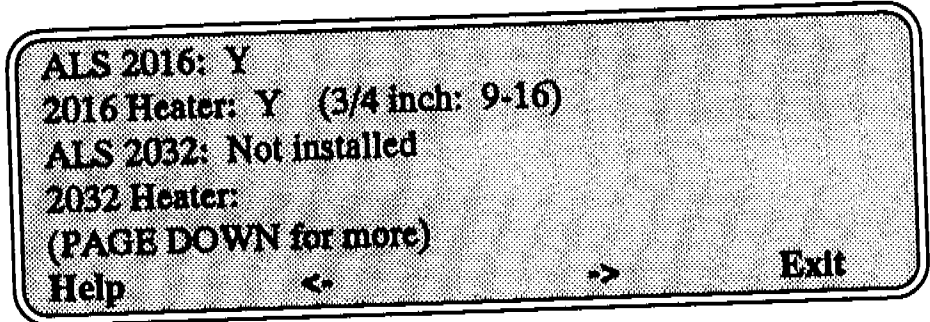

If the sample heaters will not accept a Y acknowledgment, they are either not connected to the ALS 2016 or the ALS 2032 or they did not pass the self tests.

## 8 SAMPLE HEATER INSTALLATION

### 8.10 Sample Heater Parameters

To configure the Sample Heaters into an LSC 2000 Method after having powered up the LSC 2000, you must push the reset button on the LSC 2000 rear panel. This will reinitialize the program and cause the system to run a self test.

**\*\* IMPORTANT \*\***

Do not skip the self test for the Sample Heaters. The unit will treat skips as failures and will not allow you to turn on the Automatic Sample Heater.

- 1) With the Start Up screen displayed, press F1 (Meth) to modify the parameter values.

<b>Start Up</b>	<b>Method 1</b>	<b>ALS 15</b>
Line: 80° > 100	Valve: 80° > 100	
BOT: 75° > 100	Capillary	
Mount: 35° > 40	Int: 99° > 100	
Meth ALS	Temp	Conf

**NOTE:** Method Parameter values can be modified for any Method from any Program mode screen. However, if modifications are made from any mode after the start of Preheat, the change will not take effect until the next sample.

- 2) Using the LSC 2000 keypad, enter the number of the Method you wish to use.
- 3) Press F3 (Edit) to change the parameter values (Prepurge time, Preheat time and Sample Heater temperature) for the Sample Heaters.

Method 1 selected.  
Now select action: Run or Edit

Help	Run	Edit	Exit
------	-----	------	------

8.10  
**Sample Heater  
 Parameters  
 (cont.)**

**\*\* WARNING \*\***

The maximum setpoint of a sample heater is 200°C, but Tekmar® does not recommend that the sample heaters operate above a temperature of 100°C.

Method 1 Parameters			
Standby:	30°	Prepurge:	1.50
Preheat:	5.00	Sample:	40°C
Purge:	10.00	Dry Purge:	2.00
(PAGE DOWN for more)			
Help	Run	->	Exit

There are three parameter settings to consider for sample heaters:

- a) **Prepurge Time:** Eliminates any air from the sampler before heating to prevent oxidation; desirable for some samples (e.g., oils). The formula used to determine the time is: Volume x 3/flow rate. For example, if a 10 ml sample is used in 30 ml glassware, the remaining volume is 20 ml. If the purge flow rate is 40 ml/min., the prepurge time should be set to 1.5 minutes.  
 ([20 ml x 3]/40 ml/min.=1.50 min.).  
 The total volume of each sampler is approximately:
  - 10 ml for a 5 ml sparger
  - 30 ml for a 25 ml sparger
- b) **Preheat Time:** Required for the sample to rise and equilibrate at temperature before purging to enhance quantitative reproducibility. The sample heats at an approximate rate of 20°C/min. Additional time should be allotted for larger samples, or solid samples where heat transfer is not as uniform as liquids.
- c) **Sample Heater Temperature:** Depends on the nature of the sample you intend to run.
- 4) Press F3 (->) to place the highlighted box on the parameters you wish to configure (or to change). **Prepurge** (time), **Preheat** (time), and **Sample** (Heater temperature) should be set at this time.

## 8 SAMPLE HEATER INSTALLATION

### 8.10 Sample Heater Parameters (cont.)

- 5) When all three parameter values have been entered, press **F2 (Run)** to begin the Method.

**NOTE:** Preheat (time) and Sample (Heater temperature) must have a value greater than zero for the Sample Heaters to function. Prepurge (time), however, may have a value of zero if this mode will not be used.

### 8.11 Heated/ Unheated Sample Runs

The sample heaters must be used in a sequence. For example, the top row of samplers (1-8) may be heated and the bottom row (9-16) not heated in Method Scheduling.

When running heated/unheated sample groups, a temperature setting of 0°C for the unused heaters must be programmed in Method Scheduling. (Refer to your LSC 2000 User manual for setting new values for Method Parameters).

- You do not have to remove the sample heaters from the glassware when they are not in use. Sample Heaters may be left on the glassware with their temperature set at 0°C in Method Scheduling.
- Make sure heated samples are "grouped" together and unheated samples are "grouped" together in Method Scheduling.
- Method Scheduling only allows the method to be changed three times, so only four "groups" can be run in one method.

### 8.12 Storing Sample Heaters

To insert the sample heaters in the storage unit:

- 1) Hold the power cord against the body of the sample heater. Do not bunch the power cords into the back of the bins.
- 2) Carefully slide the sample heater and its cord into the bin together, making sure the cord lays along the side of the heater as they are inserted.

**NOTE:** The top row of sample heaters have longer power cords. When tucking the heaters and cords into the bins, loop the excess cord back into the bin.

**8.13  
Ordering  
Sample Heater  
Replacement  
Parts**

Tekmar's service facilities may be contacted by calling toll free (800) 874-2004, and outside the U.S./ Canada at (513) 247-7000. Our Service Department experts can help locate the cause of a problem and can determine the best way to expedite repair. All replacement parts for the Sample Heater Accessory are listed in this section. *Please include the model and serial number of your instrument when ordering spare parts.*

***Call Tekmar Company today about mixing and matching heater types and/ or retrofitting existing assemblies.***

**Electronic**

- |                                      |  |
|--------------------------------------|--|
| <input type="checkbox"/> 14-3371-000 | Sample Heater Mother Board   |
| <input type="checkbox"/> 14-3369-000 | Sample Heater Output Board   |
| <input type="checkbox"/> 14-3118-028 | Power Switch   |
| <input type="checkbox"/> 14-1282-034 | Fuse Holder  |
| <input type="checkbox"/> 14-1283-039 | Universal Power Receptacle   |
| <input type="checkbox"/> 14-0065-034 | Fuse, 1.0 Amp  |
| <input type="checkbox"/> 14-3642-000 | Cooling Fan Assembly   |
| <input type="checkbox"/> 14-3531-000 | Pocket Heater Assy, pos. 1-8,<br>before SN 90073001                |
| <input type="checkbox"/> 14-3531-100 | Pocket Heater Assy, pos. 9-16,<br>before SN 90073001               |
| <input type="checkbox"/> 14-3531-200 | Pocket Heater Assy, pos. 1-8,<br>to include and after SN 90073001  |
| <input type="checkbox"/> 14-3531-300 | Pocket Heater Assy, pos. 9-16,<br>to include and after SN 90073001 |
| <input type="checkbox"/> 14-5071-100 | Tube Heater Assy, pos. 1-8   |
| <input type="checkbox"/> 14-5071-000 | Tube Heater Assy, pos. 9-16  |
| <input type="checkbox"/> 14-3639-000 | Wiring Kit   |

**Miscellaneous**

- |                                      |   |
|--------------------------------------|---|
| <input type="checkbox"/> 14-0094-000 | Magnetic Latch  |
| <input type="checkbox"/> 14-1646-000 | Striker Plate   |
| <input type="checkbox"/> 14-3440-000 | Door Pull   |
| <input type="checkbox"/> 14-3240-000 | Front Door, Complete  |
| <input type="checkbox"/> 14-3548-000 | Sample Heater Shipping Carton                                       |
| <input type="checkbox"/> 14-3209-000 | ALS 2016/2032 Manual (includes a<br>complete Sample Heater section) |





**SECTION 9**  
**MAINTENANCE, SERVICE AND REPLACEMENT PARTS**



**9.1  
Routine  
Maintenance**

It is possible that the ALS 2016 or ALS 2032 can become seriously contaminated from a heavily contaminated sample or a bad purge gas tank. Thus, routine maintenance is crucial for optimum performance. Our Service Department experts can help locate the cause of a problem and can determine the best way to expedite repair. Please do not hesitate to call our Service department at (800) 874-2004, and locally or outside the U.S. at (513) 247-7000 for assistance.

**9.1.1  
System  
Clean-Up**

- 1) For sample-caused contamination, place the LSC 2000 in BAKE for at least an hour. In some cases longer times may be required.
- 2) Make sure Bake Gas Bypass is turned off. It may be necessary to replace the Tenax trap if contamination persists.
- 3) If contamination is due to a bad gas tank, first replace the tank and all hydrocarbon traps on the gas supply line. This may be sufficient to obtain good blanks. If not, follow the procedure given above.

**9.1.2  
Leak Checking**

While the LSC 2000, ALS 2016, and ALS 2032 are not leak-prone systems, they are leak sensitive. A quick leak test that does not require any disassembly is described in detail in Section 3.7 (adding ALS 2016 to LSC 2000), 4.7 (adding ALS 2032 to LSC 2000/ALS 2016), or 5.7 (ALS 2016/ALS 2032/LSC 2000 installed together).

If all positions indicate a leak, the following fittings (listed in order of greatest possibility) should be checked as described in Section 3.7 (ALS 2016) or 4.7 (ALS 2032) :

- a. glassware mounts
- b. sample needle fittings
- c. connections to the 2000

## 9 MAINTENANCE, SERVICE AND REPLACEMENT PARTS

### 9.2 Installing 3/4" Fittings and Glassware Kits

*Before beginning installation, check the parts list to make sure all the necessary parts are included in the kit box.*

*You will need the following tools for assembly:*

- 1/4" open-end wrench (2)
- 11/16" open-end wrench (2)
- Phillips screwdriver (1)

If you have a unit with the 3/4" fittings installed, skip to the glassware installation instructions on the next page. Refer to the ALS 2016/ALS 2032 3/4" Glassware Kits Diagram in the back of the manual to assist with installation.

#### **Installing 3/4" Sample Mount Fittings onto the ALS 2016/ALS 2032**

- 1) Turn off the power to the ALS 2016 and/or ALS 2032.
- 2) Position the unit to gain access to both sides.
- 3) Remove the white cover panel of the unit by loosening the ten 1/4" turn screws (4 on each side, 2 on the back). Pull the panel up and away from the unit.
- 4) Remove the old purge line from the front of the unit with the 1/4" open-end wrench.
- 5) From the inside of the unit, remove the sample line from the back of the 1/2" mount with the 1/4" wrench.
- 6) From the inside of the unit, remove the nut from the 1/2" mount with the 11/16" wrench and carefully remove the lock washer.
- 7) Install the new 3/4" mount and reconnect the sample line to the back of the mount with the nut and washer.
- 8) Install the purge line on the front of the unit using both wrenches.

**9.2  
Installing  
3/4" Fittings and  
Glassware Kits  
(cont.)**

**Installing 3/4" Glassware w/ the 6 mm Dip Tube**

- 1) Slide the dip tube (nipple side down) through the sample mount.
- 2) Slide a 6 mm Teflon® ferrule set and knurled nut onto the tube and hand tighten the knurled nut temporarily.
- 3) Place the 3/4" Teflon® ferrule in the 3/4" Swagelok nut and slide these onto the sample tube.
- 4) Carefully insert the 3/4" glassware up into the sample mount all the way.
- 5) Before tightening the 3/4" nut, back the glassware down from the fitting 1 to 2 mm and then hand tighten.
- 6) Slide the other 1/4" knurled nut onto the dip tube.
- 7) Insert the 6 mm Teflon® ferrule into the knurled nut.
- 8) Hold the reducing union stationary and hand tighten the knurled nut onto the dip tube.
- 9) Connect the new purge line to the 1/4-1/16" reducing union and hand tighten.
- 10) Leak check according to Section 3.7 of the ALS 2016/ALS 2032 User Manual.

*To adjust the dip tube:*

- a) For water or soil analysis, position the dip tube all the way to the bottom of the glassware for maximum purge efficiency. Carefully hand tighten the 1/4" knurled nut.
- b) For headspace sweep, insert the dip tube just above the top of the sample and hand tighten the 1/4" knurled nut.

## **9 MAINTENANCE, SERVICE AND REPLACEMENT PARTS**

### **9.2 Installing 3/4" Fittings and Glassware Kits (cont.)**

#### **Installing the 3/4" Glassware w/ the 16 ga. Needle**

- 1) Slide the 3/4" Teflon® ferrule and the 3/4" Swagelok nut onto the sample tube.
- 2) Carefully insert the 3/4" glassware up into the sample mount all the way.
- 3) Before tightening the 3/4" nut, back the glassware down from the fitting 1 to 2 mm and then hand tighten.
- 4) Place the 1/4-1/16" reducing Teflon® ferrule on top of the 3/4" sample fitting and loosely connect the 1/4" knurled nut.
- 5) Slide the needle of the sample valve assembly through the knurled nut and into the glass tube. Hand tighten the knurled nut onto the needle.
- 6) To adjust the position of the needle inside the glassware, loosen the knurled nut, lower or raise the sample valve assembly, and retighten the knurled nut.
- 7) Connect the new purge line from the purge bulkhead to the sample valve assembly.
- 8) Leak check according to Section 3.7.

**9.3  
ALS 2016/  
ALS 2032  
Spare Parts  
List**

Tekmar's factory service facilities may be contacted by calling toll free (800) 874-2004, and locally or outside the U.S. at (513) 247-7000. All replacement parts for the ALS 2016 and ALS 2032 are listed in this section. *Please include the model and serial number of your instrument when ordering spare parts.*

**Sample Handling**

- |                                      |  |
|--------------------------------------|--|
| <input type="checkbox"/> 14-2337-024 | 5 ml Frit Sampler                                |
| <input type="checkbox"/> 14-2334-024 | 25 ml Frit Sampler                               |
| <input type="checkbox"/> 14-2336-024 | 5 ml Fritless Sparger                            |
| <input type="checkbox"/> 14-2333-024 | 25 ml Fritless Sparger                           |
| <input type="checkbox"/> 14-3021-000 | 5 ml Fritted Sparge Kit                          |
| <input type="checkbox"/> 14-3022-000 | 25 ml Fritted Sparge Kit                         |
| <input type="checkbox"/> 14-3023-000 | 5 ml Fritless Sparge Kit                         |
| <input type="checkbox"/> 14-3024-000 | 25 ml Fritless Sparge Kit                        |
| <input type="checkbox"/> 14-2977-000 | 5 ml Fritted Sparger Kit<br>(contains 16 sets)   |
| <input type="checkbox"/> 14-2978-000 | 25 ml Fritted Sparger Kit<br>(contains 16 sets)  |
| <input type="checkbox"/> 14-2979-000 | 5 ml Fritless Sparger Kit<br>(contains 16 sets)  |
| <input type="checkbox"/> 14-2980-000 | 25 ml Fritless Sparger Kit<br>(contains 16 sets) |
| <input type="checkbox"/> 14-3195-053 | 5 ml Sample Needle                               |
| <input type="checkbox"/> 14-3196-053 | 25 ml Sample Needle                              |
| <input type="checkbox"/> 14-3124-016 | Sample Fritless Nut                              |
| <input type="checkbox"/> 14-3123-016 | Sample Fritless Ferrule                          |
| <input type="checkbox"/> 14-0036-050 | 3 Port Sample Introduction Valve                 |
| <input type="checkbox"/> 14-3197-100 | Purge Line (top)                                 |
| <input type="checkbox"/> 14-3198-100 | Purge Line (bottom)                              |
| <input type="checkbox"/> 14-0216-016 | Female Luer Connector for<br>Sample Valve        |
| <input type="checkbox"/> 14-2887-016 | Sample Fitting Assembly                          |
| <input type="checkbox"/> 14-3137-200 | Drain Line assembly (top)                        |
| <input type="checkbox"/> 14-3137-300 | Drain Line Assembly (bottom)                     |
| <input type="checkbox"/> 14-0217-016 | Needle Bushing for Drain Lines                   |

## 9 MAINTENANCE, SERVICE AND REPLACEMENT PARTS

### 9.3 ALS 2016/ ALS 2032 Spare Parts List (cont.)

#### Syringes

- 14-0069-052 5 ml Sample Syringe  
w/ Luer Connector
- 14-0070-052 25 ml Sample Syringe  
w/ Luer Connector
- 12-0089-052 10  $\mu$ l Calibration Syringe
- 14-0114-050 Syringe Valve, 2 Port  
w/ Luer Connector
- 14-0122-016 Male Luer Fitting for Syringe Valve

#### Fittings

- 14-2888-016 Purge Bulkhead
- 14-1301-016 Ferrules, Teflon<sup>®</sup>, 1/2"
- 14-0442-016 Ferrules, Teflon<sup>®</sup>, 1/16"
- 14-0223-016 Gripper Fitting, 1/16"
- 14-0264-016 Union, Bulkhead, Upchurch, 1/16", SS
- 14-0159-016 Nut, Swagelok, 1/16", SS
- 14-3296-016 Plug Nut, Swagelok, 1/16", SS
- 14-0242-016 Nut, Long, Valco, for 1/16" tube
- 14-0243-016 Nut, Short, Valco, for 1/16" tube
- 14-2950-016 Nut, Extra Long, Valco, for 1/16" tube
- 12-0069-016 Nut, Brass, Swagelok, for 1/8" tube
- 14-0053-016 Elbow, Male, 1/8", NPT, Brass,
- 14-0052-016 Tee, Brass, 1/8"
- 12-0064-016 Bulkhead, Brass, 1/8" tube to 1/8" tube  
stud
- 14-0054-016 Connector, 1/16" tube to 1/8" NPT,  
Brass

#### Tubing

- 14-0441-002 Tubing, 1/16", Nickel, Large Bore
- 14-0440-002 Tubing, 1/16", Teflon FEP, Vacuum  
Baked
- 14-0546-002 Tubing, 1/8", Copper

#### Electronics



**9.3  
ALS 2016/  
ALS 2032  
Spare Parts  
List (cont.)**

- 14-3086-000 Mother Board Assembly
- 14-2582-000 Output Board Assembly
- 14-3262-000 Logic Board Assembly (ALS 2016)
- 14-3263-000 Logic Board Assembly (ALS 2032)
- 14-3164-029 Cable, Output Board to Logic Board
- 14-3199-000 Cable, 34 Port Valve Ribbon
- 14-3200-000 Cable, 34 Port Valve, Power
- 14-3201-000 Cable, 8 Port Valve (ALS 2032)

**Miscellaneous**

- 14-3310-000 Sample Heater Assembly for ALS 2016
- 14-2915-000 Drain Manifold
- 14-3110-000 Drain Manifold Assembly (Top)
- 14-3111-000 Drain Manifold Assembly (Bottom)
- 14-3202-000 Wire Harness (Top Drain)
- 14-3203-000 Wire Harness (Bottom Drain)
- 14-3204-050 Valve, 34 Port w/ slider
- 14-3205-050 Actuator for 34 Port Valve
- 14-2901-050 Valve, 8 Port, Assembly (ALS 2032)
- 14-3206-050 Valve, 8 Port w/ slider (ALS 2032)
- 14-3207-050 Actuator for 8 Port Valve (ALS 2032)
- 14-3259-050 Slider, 8 port Valve (ALS 2032)
- 14-3208-000 Valve Heater Assembly
- 14-3118-028 Power Switch
- 14-1282-034 Fuse Holder
- 14-3304-034 Fuse, 6 AMP Rectifier (ALS 2016)
- 14-3255-034 Fuse, 7 AMP Rectifier (ALS 2032)
- 14-3261-019 Fan Assembly, 12VDC, 3" Sq.
- 14-0016-000 Fan Guard
- 14-0078-035 Terminal Strip, 6 Pole
- 14-0298-039 Universal Power Cord
- 14-4091-000 Sample Mount Wrench
- 14-3209-000 Instruction Manual (2016/2032)



**SECTION 10**  
**TROUBLESHOOTING**

---



**10.1  
ALS 2016/  
ALS 2032  
Electronic  
Problems**

**#1  
Unsuccessful  
self tests**

This section is intended as a guide to troubleshoot your ALS 2016/ALS 2032 electronics. Refer to the Rear View, Upper Right View, Lower Right View and Actuator Valve diagrams in Section 11.

**CHECK**

**ACTION**

- |  |  |
|--|--|
| A. Are all power switches (LSC 2000, ALS 2016 and/or 2032 and Sample Heater) on?   | A. YES: Proceed to B.<br>NO: Turn on all switches.   |
| B. Are fuses F1 and F2 good?   | B. YES: Proceed to C.<br>NO: Replace fuse and retest. If failure still occurs, proceed to B.             |
| C. Does the screen read failure?   | C. YES: Proceed to D.<br>NO: Proceed to F.   |
| D. Are the resistance values for all sample heaters valid? Specifically the one that reads error on the screen?<br>Valve 1 = 290 ohms<br>Line = 40<br>Valve 2 = 290 ohms | D. YES: Proceed to E.<br>NO: Replace or repair heater.   |
| E. Disconnect the fan and valve outputs. Do fuses still blow?  | E. YES: Call the Tekmar Service Dept.<br>NO: Plug in components one at a time. Replace faulty component. |
| F. Did the displayed temperature increase slightly?  | F. YES: Replace the CPU Board.<br>NO: Proceed to G.  |
| G. Does the L.E.D. light on the output board stay on?  | G. YES: Replace Output Board.<br>NO: Replace Logic Board.  |

**#1**  
**Unsuccessful**  
**self tests**  
**(cont.)**

**#2**  
**LSC 2000 will**  
**not allow you**  
**to install the**  
**ALS 2016/**  
**2032**

**#3**  
**Multiposition**  
**valve does**  
**not step.**

**#4**  
**Invalid or**  
**erratic**  
**temperature**  
**display**

**CHECK**

H. Unplug the thermocouple in question. Does the temperature rise to 410°C?

A. Did the unit successfully complete self testing?

A. Does indicated valve position match the flow of gas?

B. Press F2 for the ALS screen. The step button should step the valve manually. Does the valve step when this is done?

C. Are the ALS 2016/ ALS 2032 start and stop parameters valid?

D. Check and reseal ribbon cable between ALS Mother board and the valve board. Does the valve manually step?

A. Is the 37 conductor cable connected and secured with screws?

B. Remove and reseal Logic and Output Boards. If problem persists, replace Logic or Output Board.

**ACTION**

H. YES: Repair or replace the thermocouple.  
NO: Replace Output or Logic Board.

A. YES: Replace CPU Board.  
NO: Refer to #1.

A. YES: Proceed to B.  
NO: Proceed to D.

B. YES: Proceed to C.  
NO: Proceed to D.

C. YES: Replace CPU Board.  
NO: Reprogram parameters.

D. NO: Replace ALS Logic or Output Board or valve boards.

A. YES: Refer to #1.  
NO: Secure cables.

**10.1**  
**ALS 2016/  
ALS 2032**  
**Electronic**  
**Problems**  
**(cont.)**

**#5**  
**Heaters will**  
**not heat**

**#6**  
**Drain does**  
**not work.**

**10.2**  
**Automatic**  
**Sample Heater**  
**Electronic**  
**Problems**

**#1**  
**Will not**  
**successfully**  
**pass self**  
**test.**

**CHECK**

**ACTION**

A. Refer to problem #1,  
excluding #1 B.

A. Is the system configured  
for the drain function?

A. YES: Proceed to B.  
NO: Configure for it.

B. Is the drain valve receiv-  
ing 12 Volts DC?

B. YES: Replace valve.  
NO: Replace Logic or  
Output Board.

This section is intended as a guide to troubleshoot the Sample  
Heater Accessory electronics.

A. Are all cables properly  
attached and secure with  
screws?

A. YES: Proceed to B.  
NO: Secure cables and  
retest.

B. Is fuse F1 good?

B. YES: Proceed to C.  
NO: Replace fuse and  
retest. If failure  
persists, proceed to  
C.

C. Are resistance valves for  
each heater approximately  
170 ohms?

C. YES: If fuses blow,  
proceed to D. If  
fuses don't blow,  
proceed to E.  
NO: Repair or replace  
heater.

D. Disconnect fan. Do fuses  
still blow?

D. YES: Call Tekmar  
Service Dept.  
NO: Replace fan.

**10.2  
Automatic  
Sample Heater  
Electronic  
Problems  
(cont.)**

**Unsuccessful  
self tests  
(cont.)**

**CHECK**

**ACTION**

E. Does temperature increase slightly?

E. YES: Replace CPU Board.  
NO: Proceed to F.

F. Does the displayed sample position match the gas flow?

F. YES: Proceed to G.  
NO: Refer to ALS 2016/ALS 2032 Electronics Problems #3.

G. Unplug the thermocouple in question. Does the temperature display read 410°C, indicating an open thermocouple?

G. YES: Repair or replace the thermocouple.  
NO: Replace ALS Logic or Heater Accessory Output Board.

A. Did unit successfully complete self test?

A. YES: Replace CPU Board.  
NO: Refer to problem #1.

A. Have time parameters been programmed for the Prepurge and Preheat modes?

A. YES: Replace CPU Board.  
NO: Program time parameters for each mode.

A. Refer to problem #1.

**#2  
LSC 2000 will  
not allow  
Installation of  
Sample  
Heater  
Accessory.  
#3  
LSC 2000  
skips  
Prepurge and  
Preheat**

**#4  
Heaters will  
not work.**



**SECTION 11**  
**ALS 2016/ ALS 2032 DIAGRAMS**

---



**Tekmar**

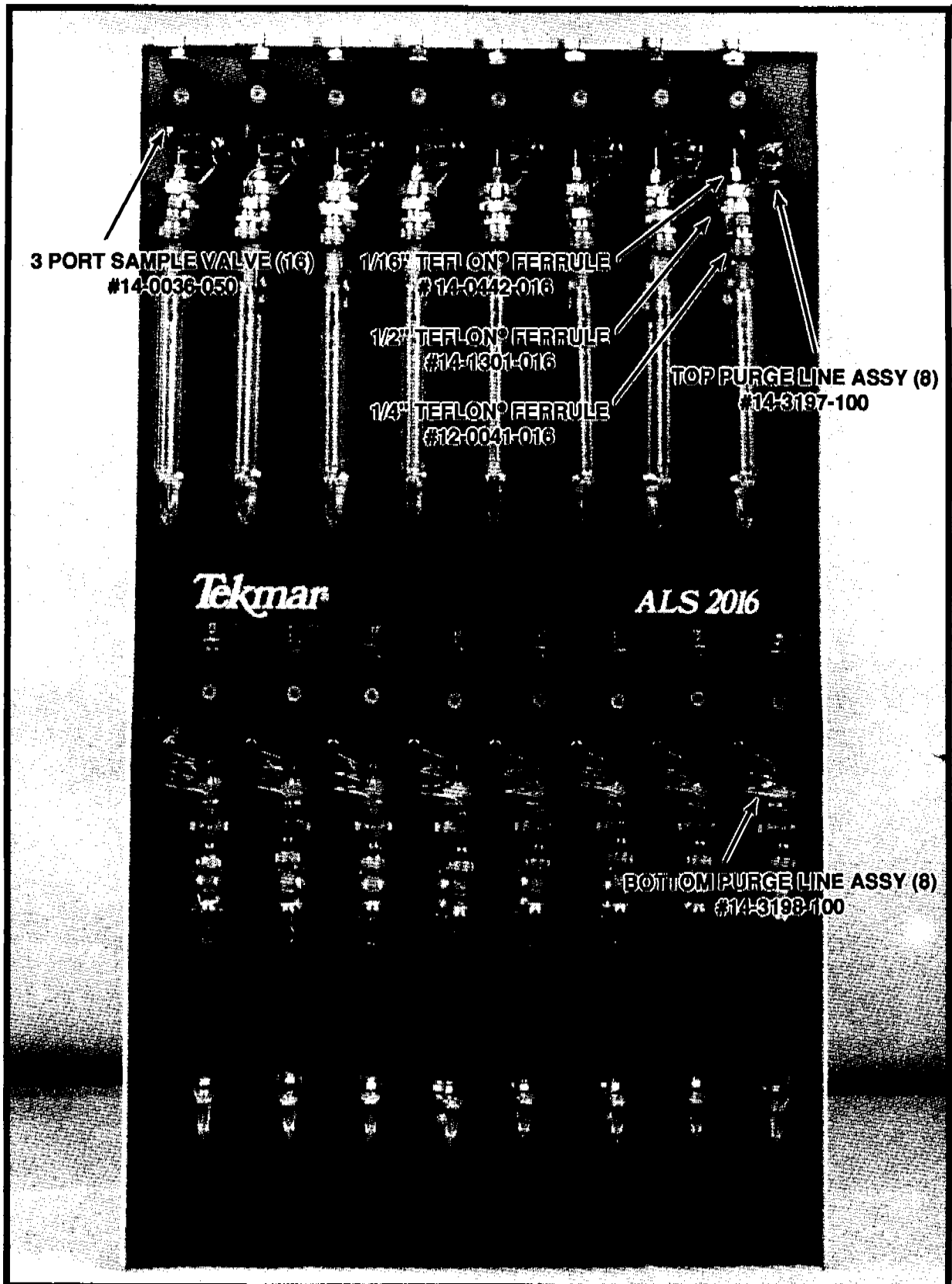

**ALS 2016 FRONT VIEW**



**Tekmar**<sup>®</sup>

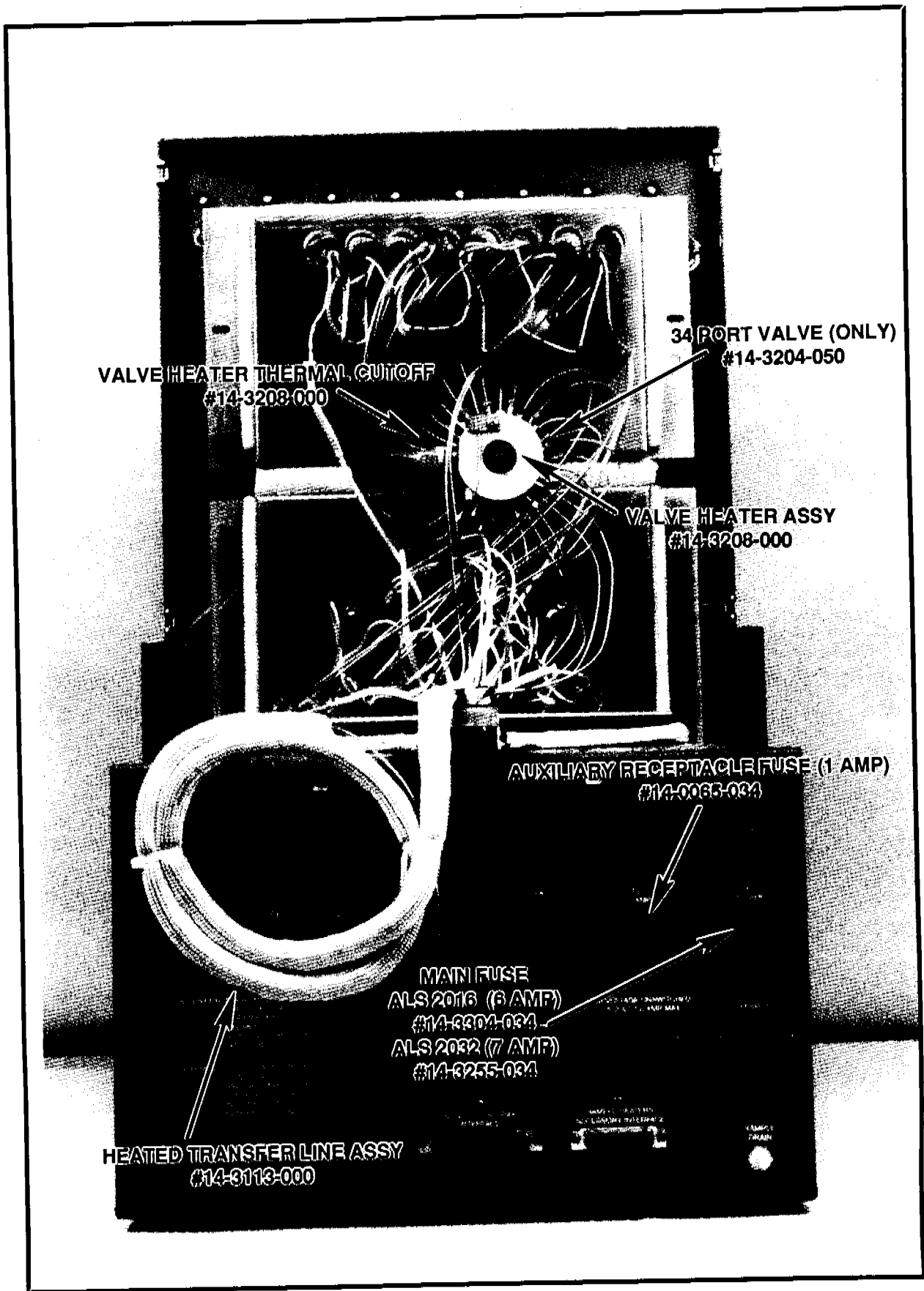

ALS 2016 REAR VIEW



**Tekmar®**

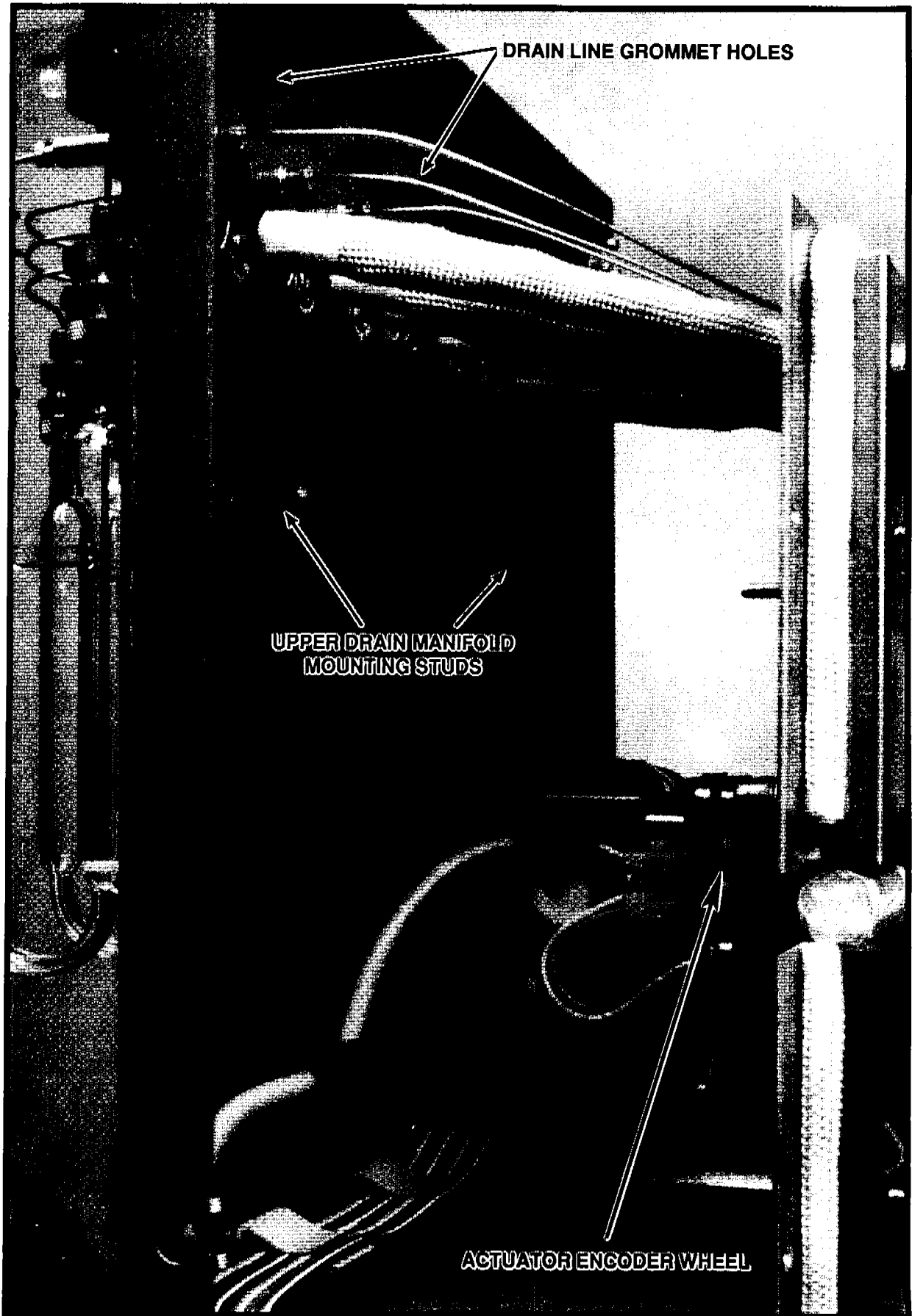

**ALS 2016 UPPER RIGHT VIEW**





**Tekmar®**

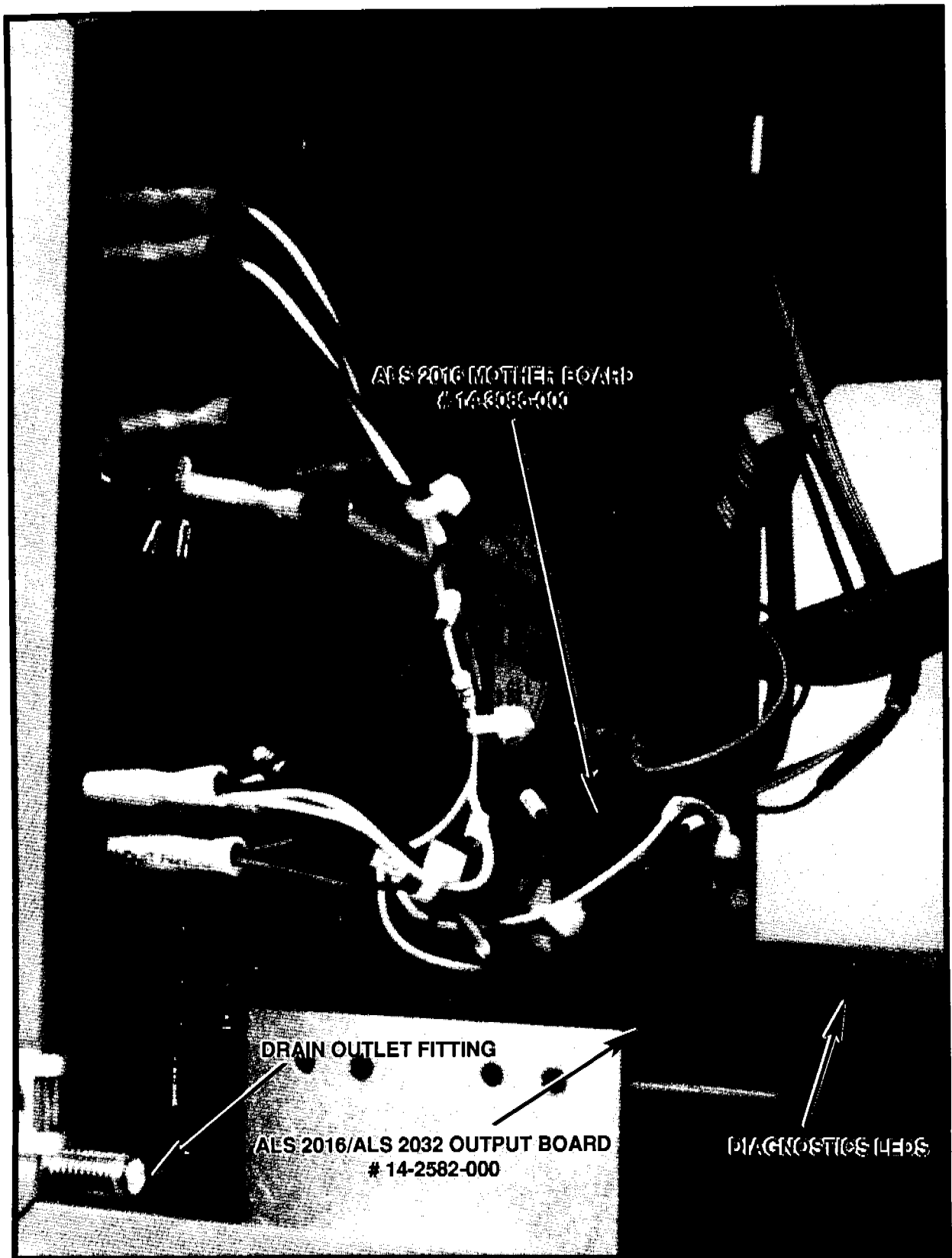

**ALS 2016 LOWER RIGHT VIEW**



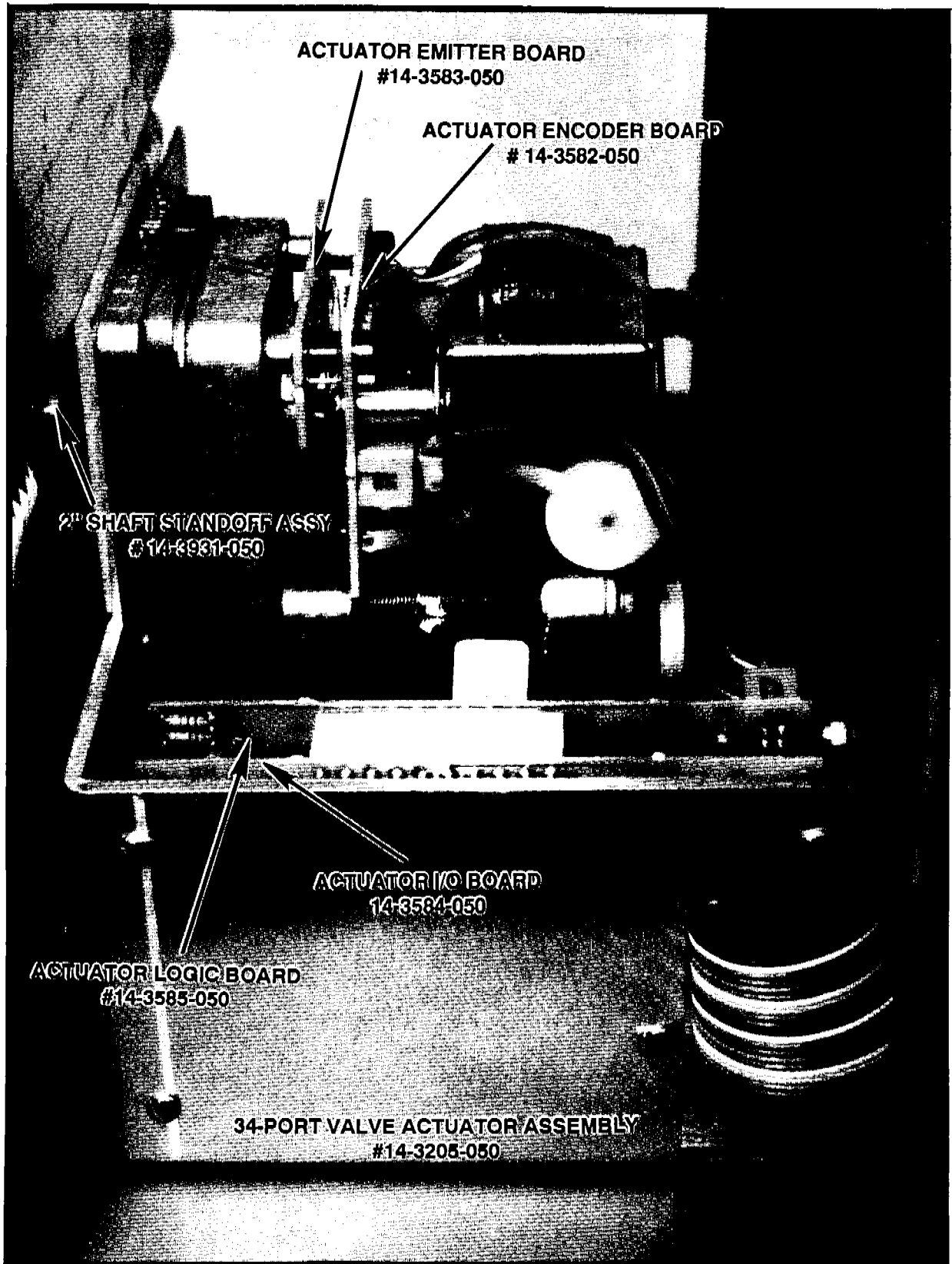

ALS 2016 ACTUATOR ASSEMBLY



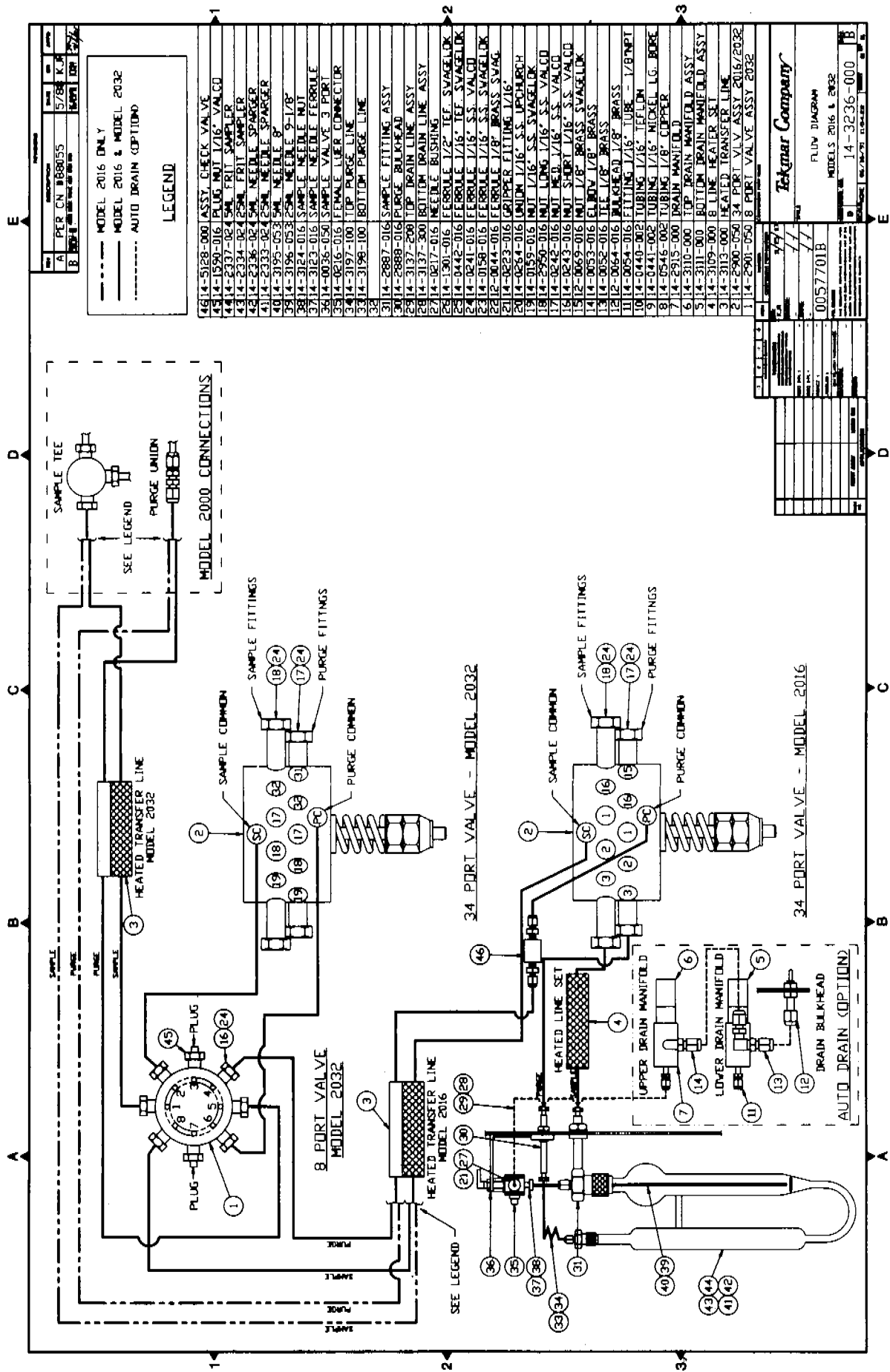

ALS 2016/2032 FLOW DIAGRAM

Tekmar Company	
FLOW DIAGRAM	
MODELS 2016 & 2032	
14-3236-000	
00577018	
REV. 10/17/91	



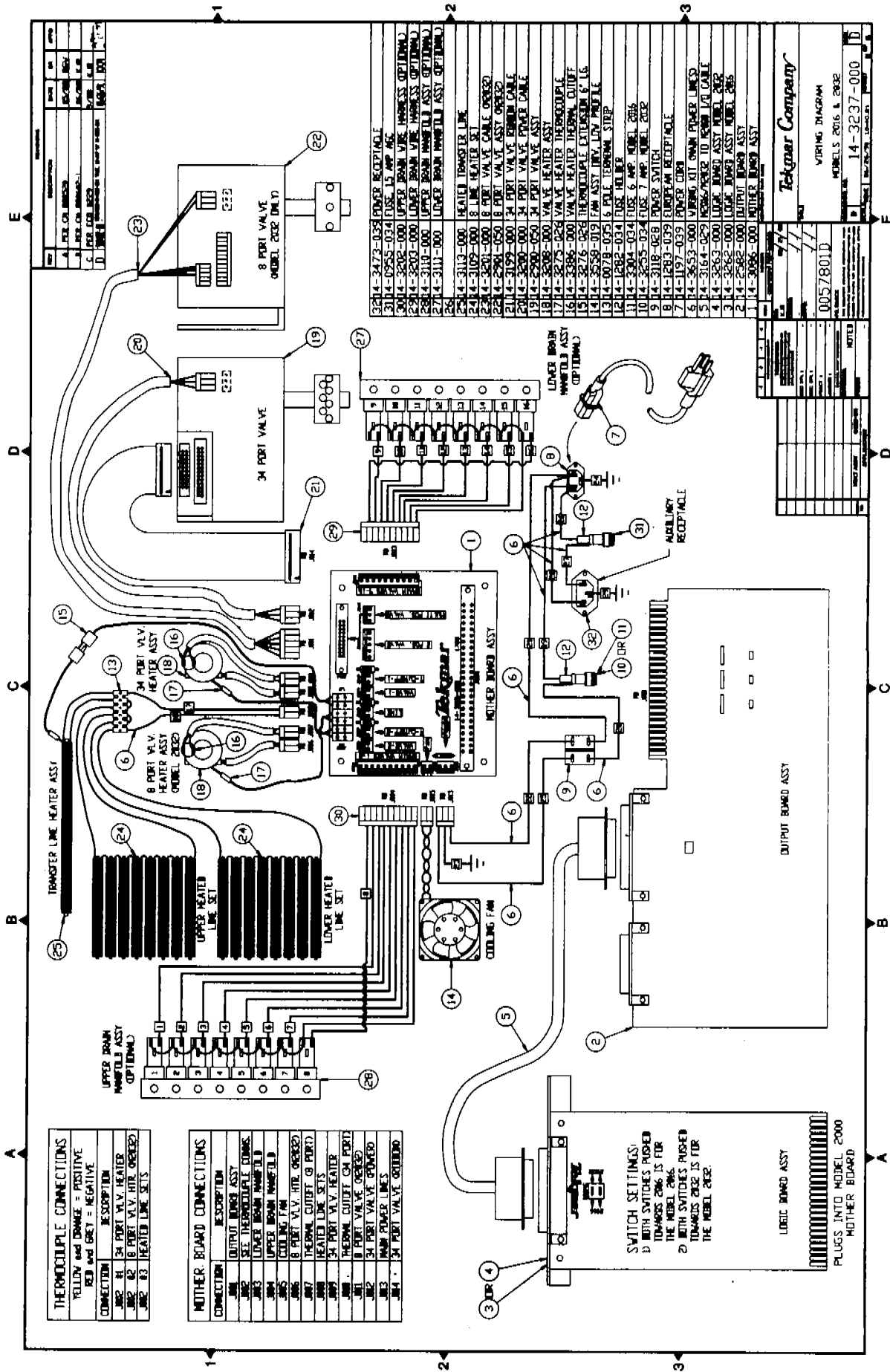

THERMOCOUPLE CONNECTIONS	
YELLOW lead CHANGE = POSITIVE	
RED and GREY = NEGATIVE	
CONNECTION	DESCRIPTION
JMC 81	34 PORT VLV. HEATER
JMC 82	8 PORT VLV. HIT ORCEAD
JMC 83	HEATER LINE SETS

MOTHER BOARD CONNECTIONS	
CONNECTION	DESCRIPTION
JMC 1	OUTPUT BOARD ASST
JMC 2	SEE THERMOCOUPLE CONNS.
JMC 3	LOWER BOARD MOTHER B
JMC 4	UPPER BOARD MOTHER B
JMC 5	CEILING FAN
JMC 6	8 PORT VLV. HIT ORCEAD
JMC 7	THERMAL CUTOFF (8 PORT)
JMC 8	HEATER LINE SETS
JMC 9	34 PORT VLV. HEATER
JMC 10	THERMAL CUTOFF (8 PORT)
JMC 11	8 PORT VLV. HEATER
JMC 12	34 PORT VLV. HEATER
JMC 13	MAIN POWER LINES
JMC 14	34 PORT VLV. HEATER

3114-3473-033	FINGER RECEPTACLE
3114-0925-034	DISC 13 AMP AGC
3114-3202-000	UPPER BOARD VLV. MOTHER B (OPT. IMA)
3114-3203-000	LOWER BOARD VLV. MOTHER B (OPT. IMA)
3114-3110-000	UPPER BOARD MOTHER B ASST. (OPT. IMA)
3114-3111-000	LOWER BOARD MOTHER B ASST. (OPT. IMA)
3114-3112-000	HEATER TRANSFER LINE
3114-3102-000	8 PORT HEATER SET
3114-3501-000	8 PORT VLV. HEATER
3114-3281-050	8 PORT VLV. ASST. ORCEAD
3114-3122-000	34 PORT VLV. HEATER LINE SET
3114-3500-000	34 PORT VLV. HEATER LINE SET
3114-3200-050	34 PORT VLV. ASST.
1814-3200-000	VALVE HEATER ASST.
1714-3275-028	VALVE HEATER THERMOCOUPLE
1614-3286-000	VALVE HEATER THERMAL CUTOFF
1514-3276-028	THERMOCOUPLE EXTENSION 6' L.S.
1414-3258-079	FAN ASST. TRV. LOW PROFILE
1314-0078-075	5 POLY. THERMAL STRIP
1214-1282-034	DISC HELPER
1114-3204-034	DISC 6 AMP. MODEL 2006
1014-3255-034	DISC 7 AMP. MODEL 2002
914-3118-028	PUMPER SWITCH
814-1283-039	EUROPEAN RECEPTACLE
714-1197-039	PUMPER COIL
614-3653-000	WIRING KIT (OWN POWER LINES)
514-3164-029	WIRING KIT (OWN POWER LINES)
414-3263-000	LOGIC BOARD ASST. MODEL 2002
314-3282-000	LOGIC BOARD ASST. MODEL 2006
214-2582-000	OUTPUT BOARD ASST. MODEL 2002
114-3086-000	MOTHER BOARD ASST.
114-3086-000	MOTHER BOARD ASST.

**Tekmar Company**  
 WIRING DIAGRAM  
 MODEL 2016 & 2032  
 14-3237-000

ALS 2016/ 2032 WIRING DIAGRAM (110V)





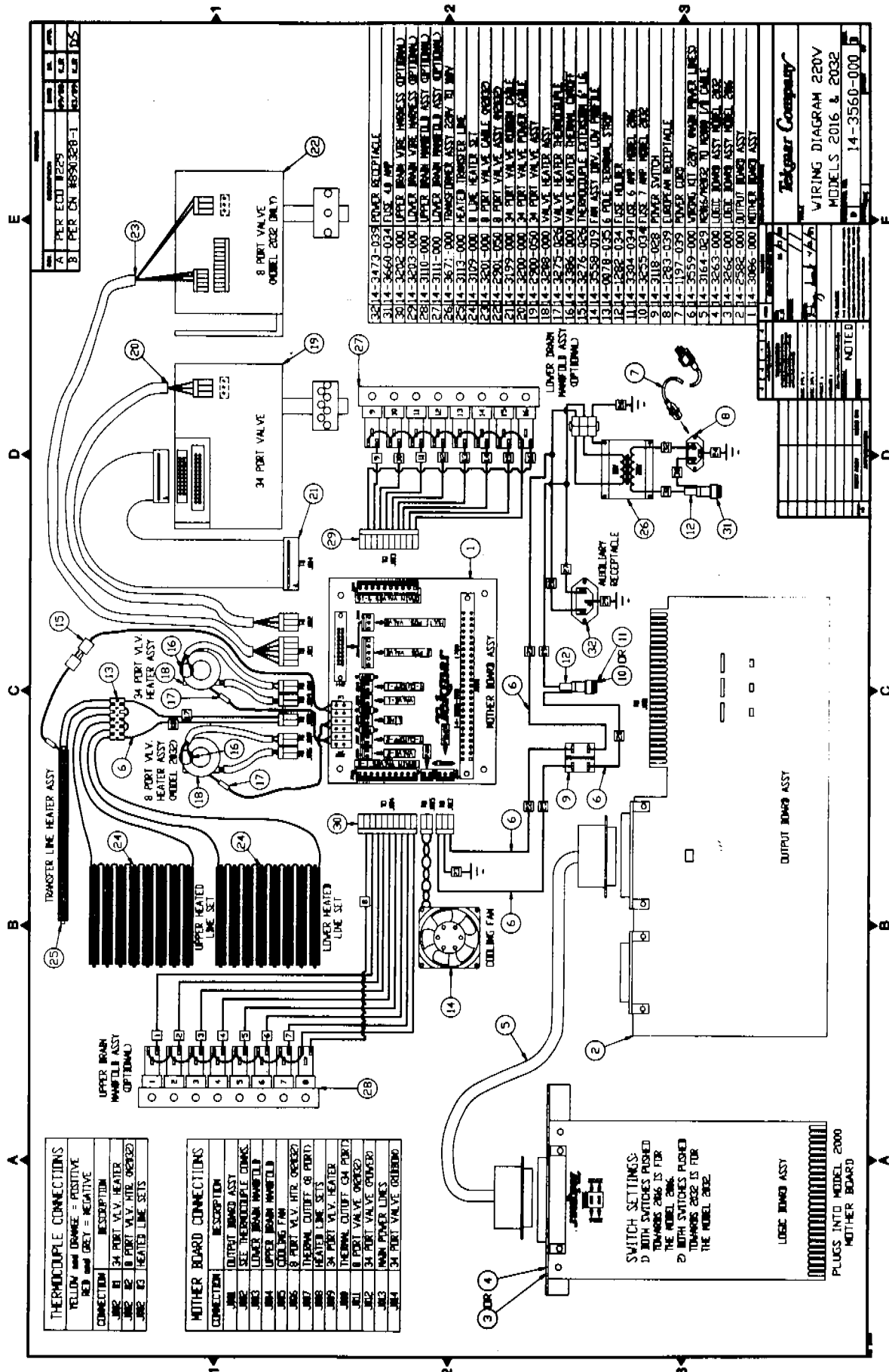

THERMOCOUPLE CONNECTIONS	
YELLOW	DRIVE = POSITIVE
RED	DRIVE = NEGATIVE
CONNECTOR	
1	34 PORT VLV HEATER
2	8 PORT VLV HEATER
3	8 PORT VLV HEATER
4	8 PORT VLV HEATER
5	8 PORT VLV HEATER
6	8 PORT VLV HEATER
7	8 PORT VLV HEATER
8	8 PORT VLV HEATER
9	8 PORT VLV HEATER
10	8 PORT VLV HEATER
11	8 PORT VLV HEATER
12	8 PORT VLV HEATER
13	8 PORT VLV HEATER
14	8 PORT VLV HEATER
15	8 PORT VLV HEATER
16	8 PORT VLV HEATER
17	8 PORT VLV HEATER
18	8 PORT VLV HEATER
19	8 PORT VLV HEATER
20	8 PORT VLV HEATER
21	8 PORT VLV HEATER
22	8 PORT VLV HEATER
23	8 PORT VLV HEATER
24	8 PORT VLV HEATER
25	8 PORT VLV HEATER
26	8 PORT VLV HEATER
27	8 PORT VLV HEATER
28	8 PORT VLV HEATER
29	8 PORT VLV HEATER
30	8 PORT VLV HEATER
31	8 PORT VLV HEATER
32	8 PORT VLV HEATER
33	8 PORT VLV HEATER
34	8 PORT VLV HEATER

MOTHER BOARD CONNECTIONS	
CONNECTOR	DESCRIPTION
1	OUTPUT BOARD ASSY
2	SEE THERMOCOUPLE CONNS.
3	LOWER BOARD HANDLE
4	UPPER BOARD HANDLE
5	COOLING FAN
6	8 PORT VLV HEATER
7	8 PORT VLV HEATER
8	8 PORT VLV HEATER
9	8 PORT VLV HEATER
10	8 PORT VLV HEATER
11	8 PORT VLV HEATER
12	8 PORT VLV HEATER
13	8 PORT VLV HEATER
14	8 PORT VLV HEATER
15	8 PORT VLV HEATER
16	8 PORT VLV HEATER
17	8 PORT VLV HEATER
18	8 PORT VLV HEATER
19	8 PORT VLV HEATER
20	8 PORT VLV HEATER
21	8 PORT VLV HEATER
22	8 PORT VLV HEATER
23	8 PORT VLV HEATER
24	8 PORT VLV HEATER
25	8 PORT VLV HEATER
26	8 PORT VLV HEATER
27	8 PORT VLV HEATER
28	8 PORT VLV HEATER
29	8 PORT VLV HEATER
30	8 PORT VLV HEATER
31	8 PORT VLV HEATER
32	8 PORT VLV HEATER
33	8 PORT VLV HEATER
34	8 PORT VLV HEATER

PARTS LIST	
3414-3473-0335	POWER RECEPTACLE
3114-3660-034	FUSE 40 AMP
3014-3200-000	UPPER BOARD VLV. (HEATER OPT. ONLY)
2914-3200-000	LOWER BOARD VLV. (HEATER OPT. ONLY)
2814-3110-000	UPPER BOARD HANDLE ASSY (OPT. ONLY)
2714-3110-000	LOWER BOARD HANDLE ASSY (OPT. ONLY)
2614-3671-000	TRANSFER LINE SET
2514-3113-000	HEATER TRANSFER LINE
2414-3109-000	8 PORT VLV. HEATER
2314-3201-000	8 PORT VLV. HEATER
2214-3201-000	8 PORT VLV. HEATER
2114-3195-000	8 PORT VLV. HEATER
2014-3200-000	8 PORT VLV. HEATER
1914-3200-000	8 PORT VLV. HEATER
1814-3200-000	8 PORT VLV. HEATER
1714-3275-026	VALVE HEATER (HEATER OPT. ONLY)
1614-3286-000	VALVE HEATER (HEATER OPT. ONLY)
1514-3275-026	INDECOMPLE EXTENSION KIT
1414-3558-019	TRM ASSY TRM. LOW. TRM. KIT
1314-0078-025	6 POLE REMOVING STOP
1214-1282-034	FUSE HOLDER
1114-3304-034	FUSE 6 AMP. MODEL 2032
1014-3255-034	FUSE 7 AMP. MODEL 2032
914-3118-028	POWER SWITCH
814-1283-029	OUTPUT BOARD
714-1197-039	POWER CORD
614-3559-000	WIRING KIT 220V. WITH LOWER BOARD VLV. (HEATER OPT. ONLY)
514-3164-029	HEATER TRANSFER LINE
414-3263-000	LOGIC BOARD ASSY. MODEL 2016
314-3263-000	LOGIC BOARD ASSY. MODEL 2032
214-2582-000	OUTPUT BOARD ASSY.
114-3086-000	MOTHER BOARD ASSY.

ALS 2016/2032 WIRING DIAGRAM (220V)



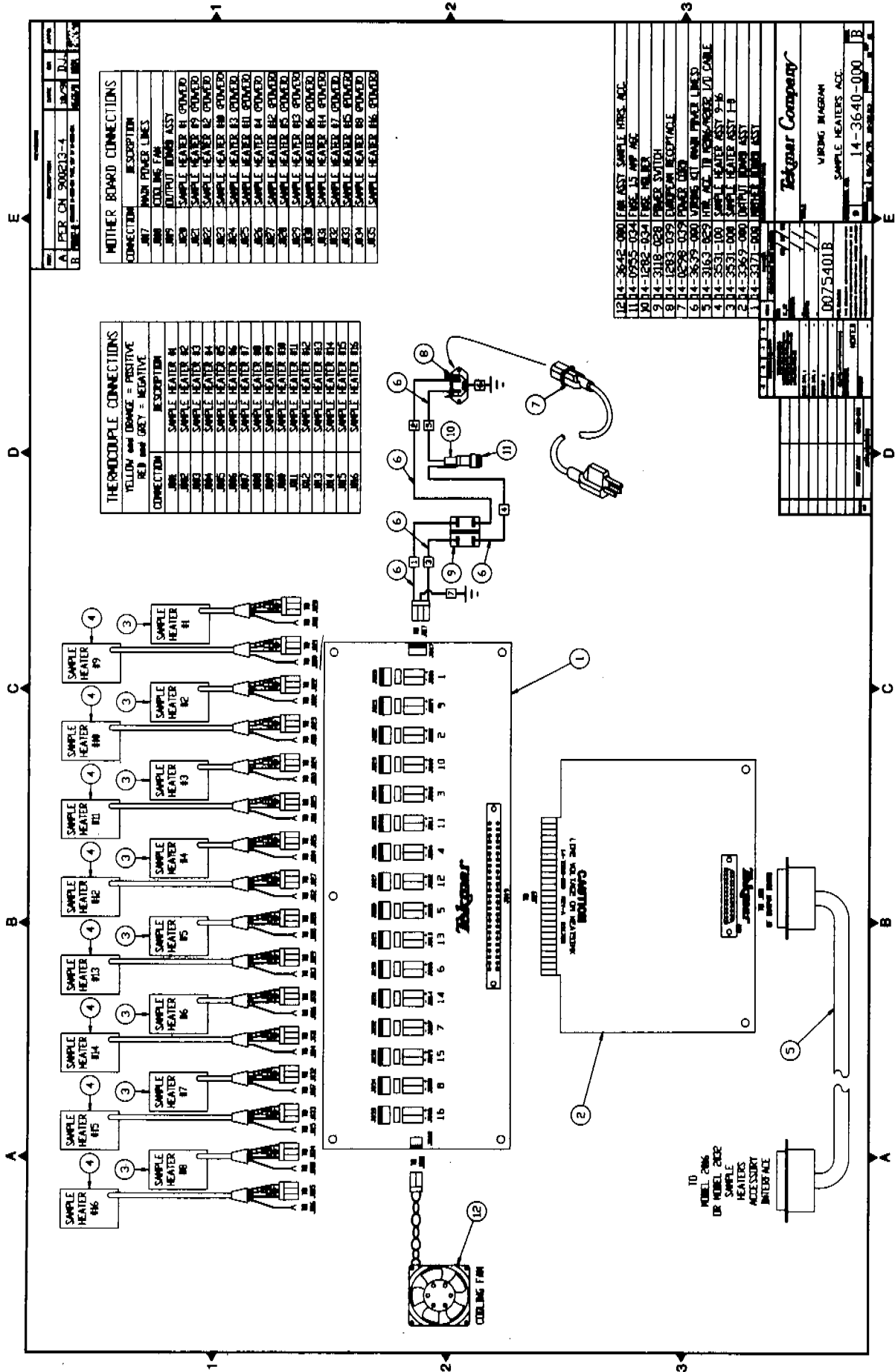

AUTOMATIC SAMPLE HEATER WIRING DIAGRAM



**Tekmar**

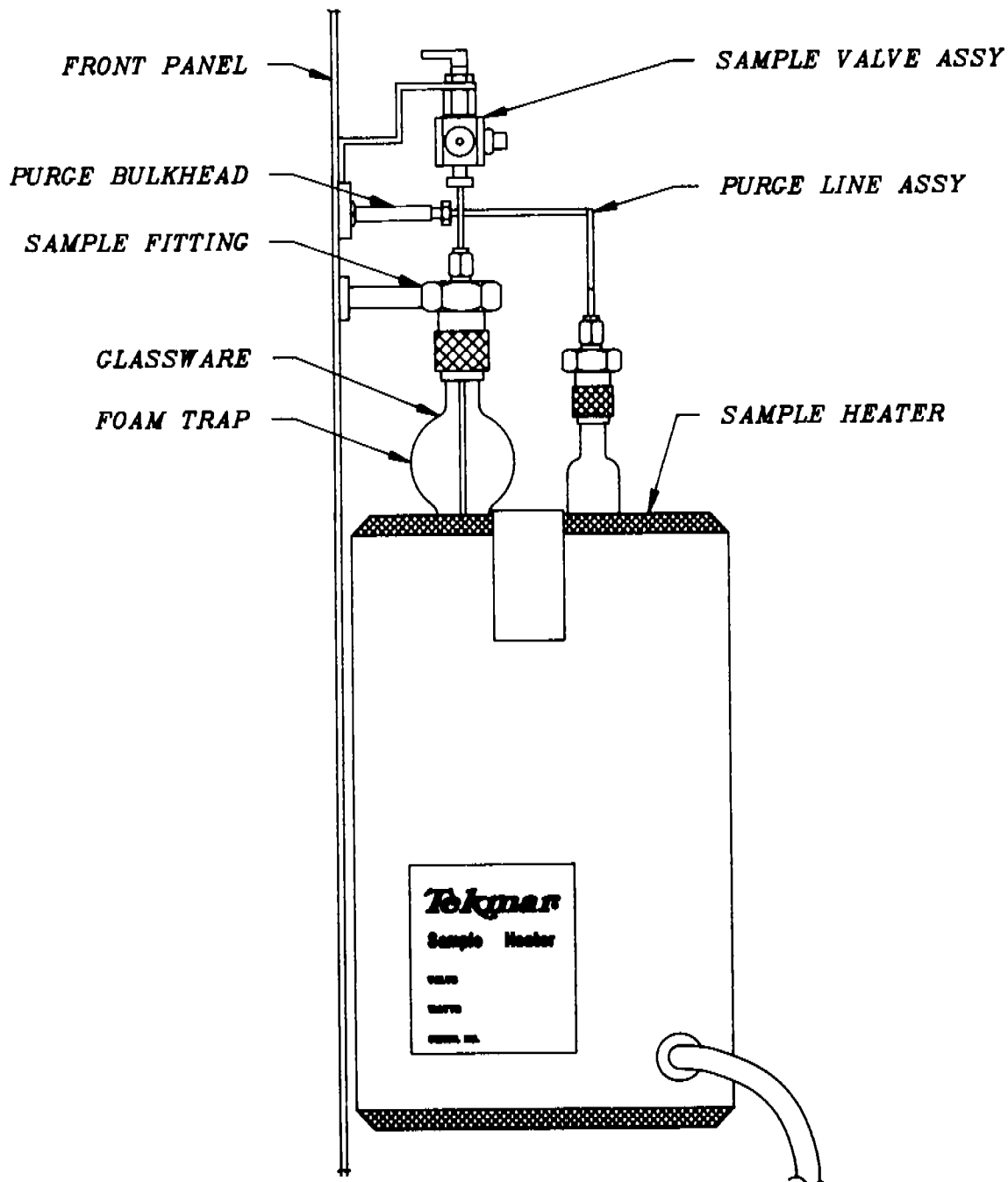

**SAMPLE HEATER POSITIONING DIAGRAM**





# ALS 2016/2032 3/4" GLASSWARE KITS

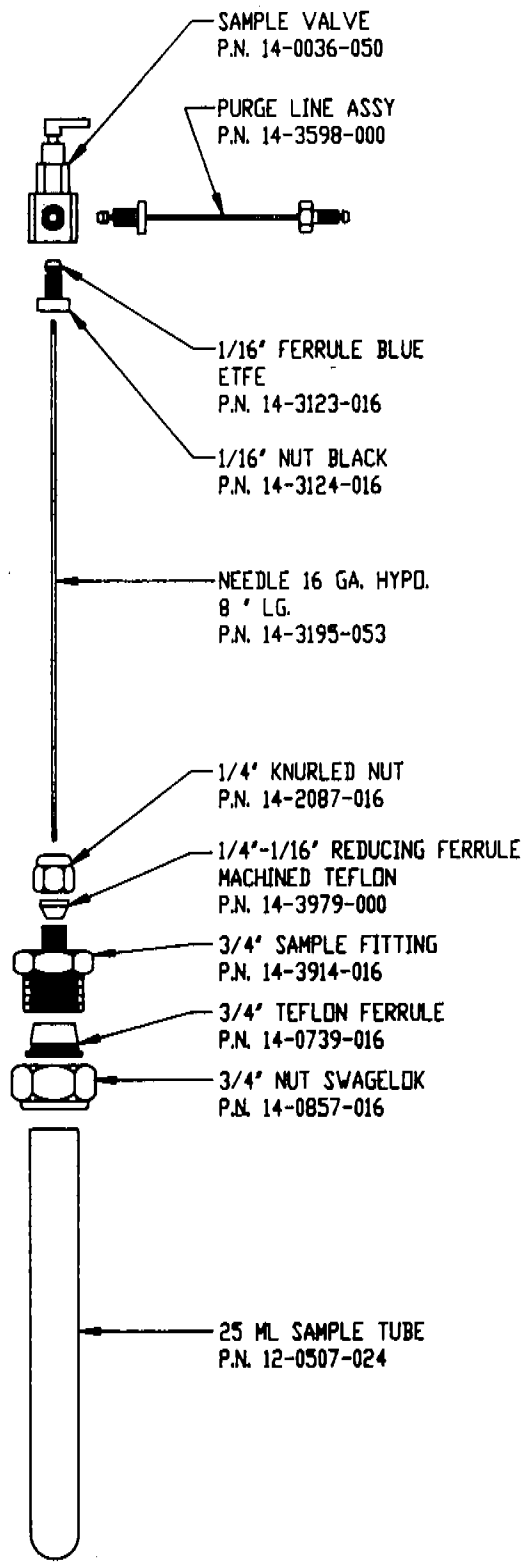
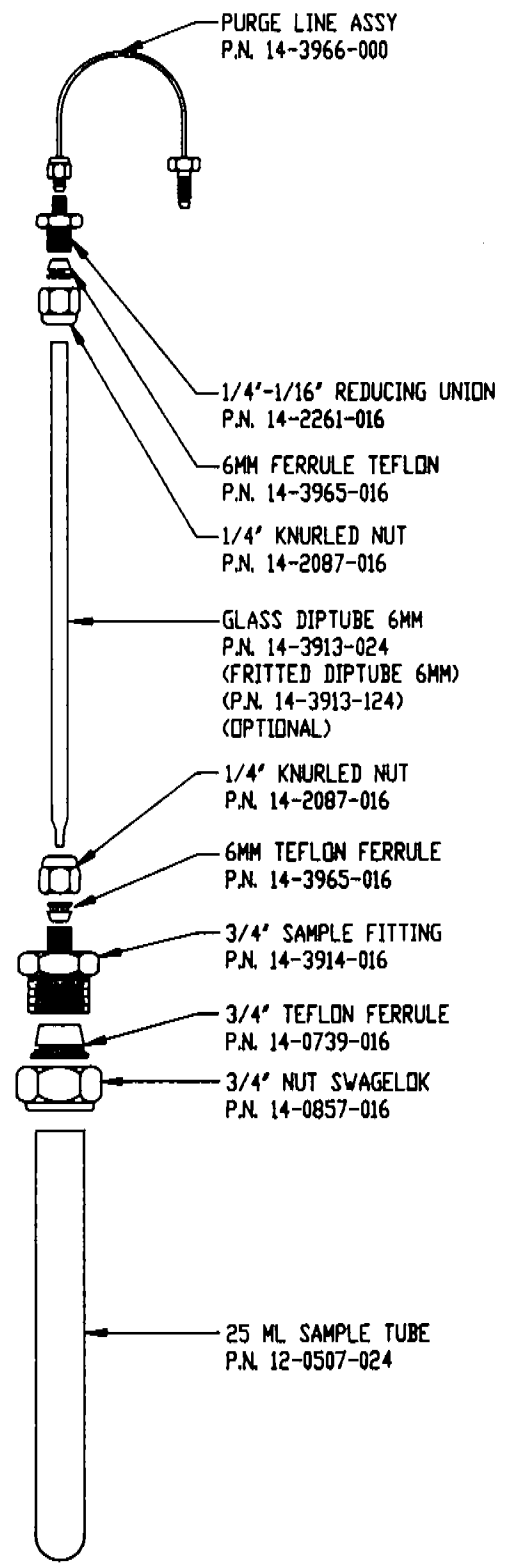

## 3/4" GLASSWARE DIAGRAM





***SECTION 12***  
***INDEX***

---



1/2" Glassware Installation 8,9,20,21,  
28,29  
3/4" Glassware Installation 61-63  
3/4" Glassware Mount Fittings  
Installation 61

## Accessories

adding to system 42  
configuring 38, 39, 42, 51-55

## ALS 2016

acknowledging to LSC 2000 38,39  
contamination 60  
electronic problems 67-69  
logic board 7, 20, 27, 28  
logic cable 8, 20, 28  
maintenance 60  
operating temperature 1  
power requirements 1, 5, 25  
purge line 7, 18, 20, 26, 28  
running sequence 34  
sample line 7, 18, 19, 26  
spare parts 59, 67-69  
transfer line 6, 18, 26

## ALS 2032

acknowledging to LSC 2000 38, 39  
contamination 60  
electronic problems 67-69  
logic board 20, 27, 28  
logic cable 20, 25, 28  
maintenance 60  
power requirements 19, 26  
purge line 20, 27  
operating temperatures 1  
sample line 18, 27  
spare parts 59, 64-66  
transfer line 19, 27

Automatic Drain Assembly  
to install 11-16

Automatic Drain  
to operate 16, 33

Automatic Sample Heaters  
electrical connections 47, 48  
power requirements 48

Automatic Sampler  
control screens 41, 43

Bake Gas Bypass 35  
Basic LSC Failure Screen 38

## Contamination

ALS 2016/ ALS 2032 60

Current Configuration Screens 38-40, 51

Configuring  
accessories 38, 39, 42, 50, 51

Drain Lines  
to connect 9, 22, 29

Drains  
not functioning 69

Electronic Problems  
ALS 2016/ ALS 2032 67-69  
Sample Heater 69-70

Electronic Module  
LSC 2000 7

"Failed to Position" Screen 45

Failure Screens 38, 45, 67

Flow System  
description 1

Fritless Spargers  
to connect 9, 21, 29

Fritted Spargers  
to connect 9, 21, 29

GC Ready Signal 8, 20, 28

Glass-Lined Tubing 17, 19, 27

Glassware  
to connect 1/2" 8, 9, 21, 28, 29  
to connect 3.4" 61-63

Gold-Plated Sample Tee 6, 18, 19, 27

## Leak Checking

adding ALS 2016 to LSC 2000 9-11  
adding ALS 2032 to LSC 2000/ ALS  
2016 22-24  
complete LSC 2000/ ALS 2016/ ALS  
2032 30-32

## Logic Board

ALS 2016 7, 20, 27, 28  
problems 68-69  
ALS 2032 20, 27, 28



problems 68-69  
**Logic Cable**  
     ALS 2016 8, 20, 28  
     ALS 2032 20, 25, 28  
**LSC 2000**  
     configurations 39, 42  
     electronics module 7, 20  
     purge gas line 6, 27  
     sample line 6, 18, 27  
     self tests 36, 37, 38  
  
**Maintenance**  
     ALS 2016/ ALS 2032 60  
**Method Parameters**  
     values 42-44, 56  
     automatic sample heaters 51-55  
**Method Scheduling** 42-43  
     multi-positions 41  
     screens 43-44  
     start and stop positions 41, 68  
**Method Screen** 51  
**Multi-Position Valve** 41  
  
**Parameter Values**  
     for method scheduling 43-44  
     sample heaters 55-55  
**Pocket Heater Installation** 48, 49, 52-54  
**Power Requirements**  
     ALS 2016 1, 5  
     ALS 2032 1, 17  
     automatic sample heater 48  
**Problems**  
     display temperature 67-68, 70  
     fuses 67, 69  
     LED 67  
     prepurge/preheat parameter values 70  
     start/ stop parameter values 68  
     thermocouple 68, 70  
**Purge Line**  
     ALS 2016, front panel connections 7,  
         20, 28  
     ALS 2016, internal connections 7,  
         18, 20, 26  
     ALS 2032, front panel connections  
         20, 28  
     ALS 2032, internal connections 20,  
         27

    LSC 2000, internal connections 6, 27  
**Purge Ready Screens** 44-45  
  
**Replacement Parts**  
     ALS 2016/ ALS 2032 67-69  
     Sample Heater 59  
  
**Sample Heaters**  
     acknowledging to LSC 2000 54-56  
     electronic problems 69-70  
     installation 49-50  
     methods 56-57  
     numbering 50  
     parameters 56-57  
     pocket heater 48-49, 52-54  
     replacements parts 59  
     sequence 57  
     storage 54, 55  
     tube heater 48, 50, 52-55  
**Sample Line**  
     ALS 2016 7, 18, 19, 26  
     ALS 2032 6, 18, 26  
     heating system 1  
     LSC 2000 6, 27  
**Sample Start and Stop Positions** 41  
**Sample Valves**  
     front panel connections 8, 21, 29  
**Samplers**  
     connections 8-9, 20-21, 28-29  
     clean-up 35  
     description 1  
**Samples**  
     loading 33  
     running in succession 42, 44, 46  
     sets of 42, 44, 46  
**Screens**  
     accessories 39, 40, 56  
     automatic sampler control 41, 43  
     current configuration 38-40  
     "failed to position" 45, 67  
     failure 38, 45, 67  
     method 56  
     method scheduling 43  
     purge ready 44-45  
     self test 36-37  
     standby 44  
     start up 39, 41-42, 51, 56



Self test screens 36-37  
Self Test  
    LSC 2000 36-38  
    LSC 2000, skipping 38, 56  
    problems 68-70  
Standby Screens 44  
Start-Up Screens 39, 41, 42, 56  
Start/ Stop Positions  
    problems 68  
    setting 41  
Syringe Use 34  
  
Transfer line  
    ALS 2016 6, 26  
    ALS 2032 19, 27  
Tube Heater Installation 50  
  
Valve heater block 6, 18, 27  
Valve heating system 1  
Valves  
    description 1  
    multi-position 41

