

# **Agilent 1100 Series Standard, Micro and Preparative Autosamplers**



**Reference Manual**



**Agilent Technologies**

## Notices

© Agilent Technologies, Inc. 2002

No part of this manual may be reproduced in any form or by any means (including electronic storage and retrieval or translation into a foreign language) without prior agreement and written consent from Agilent Technologies, Inc. as governed by United States and international copyright laws.

### Manual Part Number

G1313-90004

### Edition

Edition 07/02

Printed in Germany

Agilent Technologies  
Hewlett-Packard-Strasse 8  
76337 Waldbronn, Germany

### Software Revision

This guide is valid for A.01.xx revisions of the Agilent 1100 Series Standard, Micro and Preparative Autosamplers software, where xx refers to minor revisions of the software that do not affect the technical accuracy of this guide.

### Warranty

**The material contained in this document is provided “as is,” and is subject to being changed, without notice, in future editions. Further, to the maximum extent permitted by applicable law, Agilent disclaims all warranties, either express or implied, with regard to this manual and any information contained herein, including but not limited to the implied warranties of merchantability and fitness for a particular purpose. Agilent shall not be liable for errors or for incidental or consequential damages in connection with the furnishing, use, or performance of this document or of any information contained herein. Should Agilent and the user have a separate written agreement with warranty terms covering the material in this document that conflict with these terms, the warranty terms in the separate agreement shall control.**

### Technology Licenses

The hardware and/or software described in this document are furnished under a license and may be used or copied only in accordance with the terms of such license.

### Restricted Rights Legend

Software and technical data rights granted to federal government customers include only those rights customarily provided to end user Customers of Software. Agilent provides this customary commercial license in Software and technical data pursuant to FAR 12.211 (Technical Data) and FAR 12.212 (Computer Software) and, for Department of Defense purchases, DFARS 252.227-7015 (Technical Data - Commercial Items) and DFARS 227.7202-3 (Rights in Commercial Computer Software or Computer Software Documentation). If a federal government or other public sector Customer has a need for

rights not conveyed under these terms, it must negotiate with Agilent to establish acceptable terms in a written agreement executed by all relevant parties.

### Safety Notices

#### CAUTION

A **CAUTION** notice denotes a hazard. It calls attention to an operating procedure, practice, or the like that, if not correctly performed or adhered to, could result in damage to the product or loss of important data. Do not proceed beyond a **CAUTION** notice until the indicated conditions are fully understood and met.

#### WARNING

A **WARNING** notice denotes a hazard. It calls attention to an operating procedure, practice, or the like that, if not correctly performed or adhered to, could result in personal injury or death. Do not proceed beyond a **WARNING** notice until the indicated conditions are fully understood and met.

## In This Guide...

### **1 Installing the Autosampler**

Site requirements and installation of the autosampler and thermostatted autosampler

### **2 Optimizing Performance**

Autosamplers are more and more used in HPLC to improve the productivity in the laboratories and the consistency and accuracy of analytical results

This chapter shows how to optimize the autosamplers to achieve best results

### **3 Troubleshooting and Test Functions**

The modules built-in troubleshooting and test functions

### **4 Repairing the Autosampler**

Instructions on simple, routine repair procedures as well as more extensive repairs requiring exchange of internal parts

### **5 Parts and Materials**

Detailed illustrations and lists for identification of parts and materials

### **6 Introduction to the Autosampler**

An introduction to the standard, micro and preparative autosamplers and thermostatted autosamplers

### **7 Theory of Operation**

Theory of operation of mechanical hardware, electronics, and instrument interfaces

### **8 Introduction to the Control Module**

Introduction to the screens available for operation of the Agilent 1100 Series autosamplers with the control module

## **9 Specifications**

Performance specifications of the Agilent 1100 Series Standard, Micro and Preparative Autosamplers

# Contents

## 1 Installing the Autosampler

Site Requirements	14
Power Consideration	14
Power Cords	15
Bench Space	15
Environment	16
Unpacking the Autosampler	17
Optimizing the Stack Configuration	22
Installing the Autosampler	26
Installing the Thermostatted Autosampler	29
Flow Connections	33
Sample Trays	34
Choice of Vials and Caps	37
Transporting the Autosampler	40

## 2 Optimizing Performance

Optimization for Lowest Carry-over	42
Using the Automated Needle Wash	43
Using an Injector Program	44
General Recommendation to Lowest Carry-over	45
Fast Injection Cycle and Low Delay Volume	46
Overlapped Injection Mode	46
General Recommendations for Fast Injection Cycle Times	47
Precise Injection Volume	48

Draw and Eject Speed	48
Choice of Rotor Seal	50

### 3 Troubleshooting and Test Functions

Overview of the Sampler's Indicators and Test Functions	52
Status Indicators	53
Power Supply Indicator	53
Instrument Status Indicator	54
Error Messages	55
Timeout	56
Shutdown	57
Remote Timeout	58
Synchronization Lost	59
Leak	60
Leak Sensor Open	61
Leak Sensor Short	62
Compensation Sensor Open	63
Compensation Sensor Short	64
Fan Failed	65
Open Cover	66
Restart Without Cover	67
Arm Movement Failed	68
Valve to Bypass Failed	69
Valve to Mainpass Failed	70
Needle Up Failed	71
Needle Down Failed	72
Missing Vial	73
Initialization Failed	74
Metering Home Failed	75
Motor Temperature	76
Initialization with Vial	77
Safety Flap Missing	78

Vial in Gripper	79
Missing Wash Vial	80
Invalid Vial Position	81
Maintenance Functions	82
User Interface	83
Change Needle	84
Change Piston	86
Park Arm (Park Gripper)	87
Change Gripper (Change Arm)	88
Tray Alignment	89
Step Commands	91
Troubleshooting	93
Troubleshooting Guide for the Sample Transport Assembly	95
Intermittent lock-ups with or without vial in the gripper fingers	96
Jittery (shaky) movement in X and or theta axes and/or when the needle goes through the gripper arm into the via	98
Poor alignment, seen during vial pickup and vial replacement and/or when the needle hits the gripper arm	100

#### **4 Repairing the Autosampler**

Introduction into Repairing the Autosampler	104
Overview of Main Repair Procedures	107
Simple Repairs	108
Needle Assembly	109
Needle-Seat Assembly	112
Stator Face	115
Rotor Seal	118
Metering Seal and Plunger	122
Gripper Arm	126

Interface Board	129
Exchanging Internal Parts	130
Assembling the Main Cover	131
Top Cover and Foam	132
Installing the Top Cover and Foam	134
Transport Assembly	136
Installing the Transport Assembly	137
Sampling Unit	138
Installing the Sampling Unit	141
Injection-Valve Assembly	144
Metering-Drive Motor and Belt	147
Needle-Drive Motor and Belt	149
Fan	152
ASM Board	154
SUD Board	159
Power Supply	161
Leak Sensor	164

## 5 Parts and Materials

Main Assemblies	168
Sampling Unit Assembly	171
Analytical-Head Assembly	174
Injection-Valve Assembly	177
Sheet Metal Kit	179
Cover Parts	180
Foam Parts	181
Power and Status Light Pipes	182
Leak System Parts	183
Vial Trays	184



Autosampler Accessory Kit	<a href="#">G1313-68705</a>	186
Thermostatted Autosampler Accessory Kit	<a href="#">G1329-68705</a>	187
Micro Thermostatted Autosampler Accessory Kit	<a href="#">G1329-68715</a>	188
Preparative ALS Accessory Kit	<a href="#">G2260-68705</a>	189
Maintenance Kit	<a href="#">G1313-68709</a>	190
Multi-Draw Kit	<a href="#">G1313-68711</a>	191
900 µl Injection Upgrade Kit G1363A for G1313A / 29A		192
External Tray	<a href="#">G1313-60004</a>	193
Cable Overview		194
Analog Cables		196
Remote Cables		199
BCD Cables		205
Auxiliary Cable		208
CAN Cable		209
External Contact Cable		210
RS-232 Cable Kit		211
LAN Cables		212

## **6 Introduction to the Autosampler**

Introduction to the Autosampler	214
Sampling Sequence	216
Injection Sequence	217
Sampling Unit	219
Needle-Drive	220
Analytical head / preparative head	220
Injection-Valve	221
Transport Assembly	222

Early Maintenance Feedback (EMF)	224
EMF Counters	224
Using the EMF Counters	225
Electrical Connections	226

## 7 Theory of Operation

Autosampler Control and Electronics	230
Position and Movement Sensors	231
Autosampler Main Board (ASM)	232
Firmware Description	237
Firmware Updates	238
Optional Interface Boards	239
BCD Board	239
LAN Board	240
Interfaces	241
Analog Signal Output	242
GPIB Interface	242
CAN Interface	242
Remote Interface	242
RS-232C	244
Setting the 8-bit Configuration Switch	246
GPIB Default Addresses	247
Communication Settings for RS-232C Communication	248
Forced Cold Start Settings	249
Stay-Resident Settings	250
The Main Power Supply Assembly	251

## 8 Introduction to the Control Module

Major keys on the Agilent 1100 Control Module	254
---	-----

Screens available from the Analysis screen	255
Screens available from the System screen	266
Screens available from the Records screen	269
Diagnostics and Tests	274

## **9 Specifications**

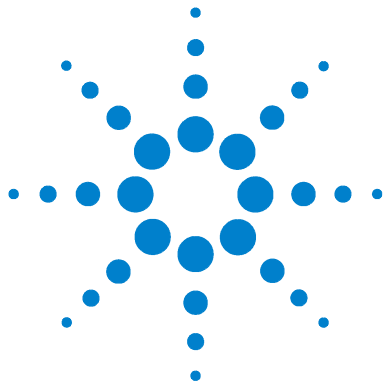
Performance Specifications	280
----------------------------	-----

## **A Safety Information**

General Safety Information	286
Lithium Batteries Information	289
Radio Interference	290
Sound Emission	291
Solvent Information	292
Agilent Technologies on Internet	293

## **Index**





# 1 Installing the Autosampler

Site Requirements	14
Unpacking the Autosampler	17
Optimizing the Stack Configuration	22
Installing the Autosampler	26
Installing the Thermostatted Autosampler	29
Flow Connections	33
Sample Trays	34
Choice of Vials and Caps	37
Transporting the Autosampler	40



### Site Requirements

A suitable site environment is important to ensure optimal performance of the autosampler.

#### Power Consideration

The autosampler power supply has wide-ranging capability. Consequently there is no voltage selector in the rear of the autosampler. There are also no externally accessible fuses, because automatic electronic fuses are implemented in the power supply.

The thermostatted autosampler comprises two modules, the autosampler and the thermostat (G1330B). Both modules have a separate power supply and a power plug for the line connections. The two modules are connected by a control cable and both are turned on by the autosampler module.

#### **WARNING**

**To disconnect the autosampler from line power, unplug the power cord. The power supply still uses some power, even if the power switch on the front panel is turned off.**

---

#### **WARNING**

**To disconnect the thermostatted autosampler from line power, unplug the power cord from the autosampler and the ALS thermostat. The power supplies still use some power, even if the power switch on the front panel is turned off. Please make sure that it is always possible to access the power plug.**

---

#### **WARNING**

**Shock hazard or damage of your instrumentation can result if the devices are connected to a line voltage higher than specified.**

---

## Power Cords

Your autosampler is delivered with a power cord which matches the wall socket of your particular country or region. The plug on the power cord which connects to the rear of the instrument is identical for all types of power cord.

**WARNING**

**Never operate your instrumentation from a power outlet that has no ground connection. Never use a power cord other than the power cord designed for your region.**

---

**WARNING**

**Never use cables other than the ones supplied by Agilent Technologies to ensure proper functionality and compliance with safety or EMC regulations.**

---

## Bench Space

The autosampler dimensions and weight (see [Table 1](#) on page 16) allow the instrument to be placed on almost any laboratory bench. The instrument requires an additional 2.5 cm (1.0 inch) of space on either side, and approximately 8 cm (3.1 inches) at the rear for the circulation of air, and room for electrical connections. Ensure the autosampler is installed in a horizontal position.

The thermostatted autosampler dimensions and weight allow the instrument to be placed on almost any laboratory bench. The instrument requires an additional 25 cm (10 inches) of space on either side for the circulation of air, and approximately 8 cm (3.1 inches) at the rear for electrical connections. Ensure the autosampler is installed in a level position.

If a complete Agilent 1100 Series system is to be installed on the bench, make sure that the bench is designed to carry the weight of all the modules. For a complete system including the thermostatted autosampler it is recommended to position the modules in two stacks, see "[Optimizing the Stack Configuration](#)" on page 22. Make sure that in this configuration there is 25 cm (10 inches) space on either side of the thermostatted autosampler for the circulation of air.

### Environment

Your autosampler will work within specifications at ambient temperatures and relative humidity as described in [Table 1](#).

#### CAUTION

Do not store, ship or use your autosampler under conditions where temperature fluctuations may cause condensation within the autosampler. Condensation will damage the system electronics. If your autosampler was shipped in cold weather, leave it in its box, and allow it to warm up slowly to room temperature to avoid condensation.

**Table 1** Physical Specifications - Autosampler (G1313A / G1329A / G1389A / G2260A)

Type	Specification	Comments
Weight	14.2 kg (31.3 lbs)	
Dimensions (height × width × depth)	200 × 345 × 435 mm (8 × 13.5 × 17 inches)	
Line voltage	100 – 120 or 220 – 240 VAC, ± 10 %	Wide-ranging capability
Line frequency	50 or 60 Hz, ± 5 %	
Power consumption (apparent power) Power consumption (active power)	300 VA 200 W	Maximum Maximum
Ambient operating temperature	4 – 55 °C (41 – 131 °F)	see on page 16
Ambient non-operating temperature	-40 to 70 °C (-4 to 158 °F)	
Humidity	< 95 %, at 25 – 40 °C (77 – 104 °F)	Non-condensing
Operating Altitude	Up to 2000 m (6500 ft)	
Non-operating altitude	Up to 4600 m (14950 ft)	For storing the autosampler
Safety standards: IEC, CSA, UL	Installation Category II, Pollution Degree 2	

#### WARNING

Using the autosampler at environmental temperatures higher than 50 °C (122 °F) may cause the rear panel to become hot.



## Unpacking the Autosampler

**CAUTION**

If you need to ship the autosampler at a later date, always park the transport assembly before shipment (see ["Transporting the Autosampler"](#) on page 40).

---

### Damaged Packaging

Upon receipt of your autosampler, inspect the shipping containers for any signs of damage. If the containers or cushioning material are damaged, save them until the contents have been checked for completeness and the autosampler has been mechanically and electrically checked. If the shipping container or cushioning material is damaged, notify the carrier and save the shipping material for the carriers inspection.

**CAUTION**

If there are signs of damage to the autosampler, please do not attempt to install the autosampler.

---

### Delivery Checklist

Ensure all parts and materials have been delivered with the autosampler. The instrument box contains the instrument and an Accessory kit. A separate box contains the reference manual and the power cable.

In [Table 3](#) on page 18, [Table 4](#) on page 20, [Table 5](#) on page 21 and [Table 6](#) on page 35 are listed the content of each accessory kit.

Please report missing or damaged parts to your local Agilent Technologies sales and service office.

## 1 Installing the Autosampler

**Table 2** G1313A - Autosampler Accessory Kit Contents G1313-68705

Description	Part Number
Tubing assembly	5063-6527
Filter promo kit	5064-8240
CAN cable	5181-1516
Screw cap vials, clear 100/pk	5182-0714
Blue screw caps 100/pk	5182-0717
Label halftray	5989-3890
Vial instruction sheet	no PN
Wrenches 1/4 - 5/16 inch	8710-0510
Rheotool socket wrench 1/4 inch	8710-2391
Hex key 4 mm, 15 cm long, T-handle	8710-2392
Hex key 9/64 mm, 15 cm long, T-handle	8710-2394
Hex key 2.5 mm, 15 cm long, straight handle	8710-2412
ESD wrist strap	9300-1408
Finger caps (x3)*	5063-6506
Tray for 40 x 2 ml vials	G1313-44502
Tray for 15 x 6 ml vials	G1313-44503
Capillary 0.17 mm 180 mm	G1313-87305

\* Reorder gives pack of 15

**Table 3** G1329A - Thermostatted Autosampler Accessory Kit Contents G1329-68705

Description	Part Number
Tubing assembly	5063-6527
Filter promo kit	5064-8240
CAN cable, 1 m long	5181-1519

**Table 3** G1329A - Thermostatted Autosampler Accessory Kit Contents  
G1329-68705 (continued)

<b>Description</b>	<b>Part Number</b>
Screw cap vials, clear 100/pk	5182-0714
Blue screw caps 100/pk	5182-0717
Label halftray	5989-3890
Vial instruction sheet	no PN
Wrenches 1/4 - 5/16 inch	8710-0510
Rheotool socket wrench 1/4 inch	8710-2391
Hex key 4 mm, 15 cm long, T-handle	8710-2392
Hex key 9/64 mm, 15 cm long, T-handle	8710-2394
Hex key 2.5 mm, 15 cm long, straight handle	8710-2412
ESD wrist strap	9300-1408
Finger caps (x3)*	5063-6506
Front door cooled autosampler	G1329-40301
Air channel adapter	G1329-43200
Cover insulation	no PN
Capillary 0.17 mm, 900 mm	G1329-87300
Capillary heat exchanger	01090-87306
Note for 1100 Series Autosampler door upgrade	no PN

\* Reorder gives pack of 15

## 1 Installing the Autosampler

**Table 4** G1389A - Micro Thermostatted Autosampler Accessory Kit Contents  
G1329-68715

Description	Part Number
Tubing assembly	5063-6527
CAN cable, 1 m long	5181-1519
Screw cap vials, clear 100/pk	5182-0714
Blue screw caps 100/pk	5182-0717
Label halftray	5989-3890
Vial instruction sheet	no PN
Fitting	79814-22406
Hex Key	8710-0060
Wrench 4 mm both ends	8710-1534
Wrenches 1/4 - 5/16 inch	8710-0510
Rheotool socket wrench 1/4 inch	8710-2391
Hex key 4 mm, 15 cm long, T-handle	8710-2392
Hex key 9/64 mm, 15 cm long, T-handle	8710-2394
Hex key 2.5 mm, 15 cm long, straight handle	8710-2412
ESD wrist strap	9300-1408
Finger caps (x3)*	5063-6506
Torque adapter	G1315-45003
Front door cooled autosampler	G1329-40301
Air channel adapter	G1329-43200
Cover insulation	no PN
Extended loop capillary 0.25 mm, 180 mm	G1329-87302
Fused silica capillary 0.050 mm, 500 mm	G1375-87304

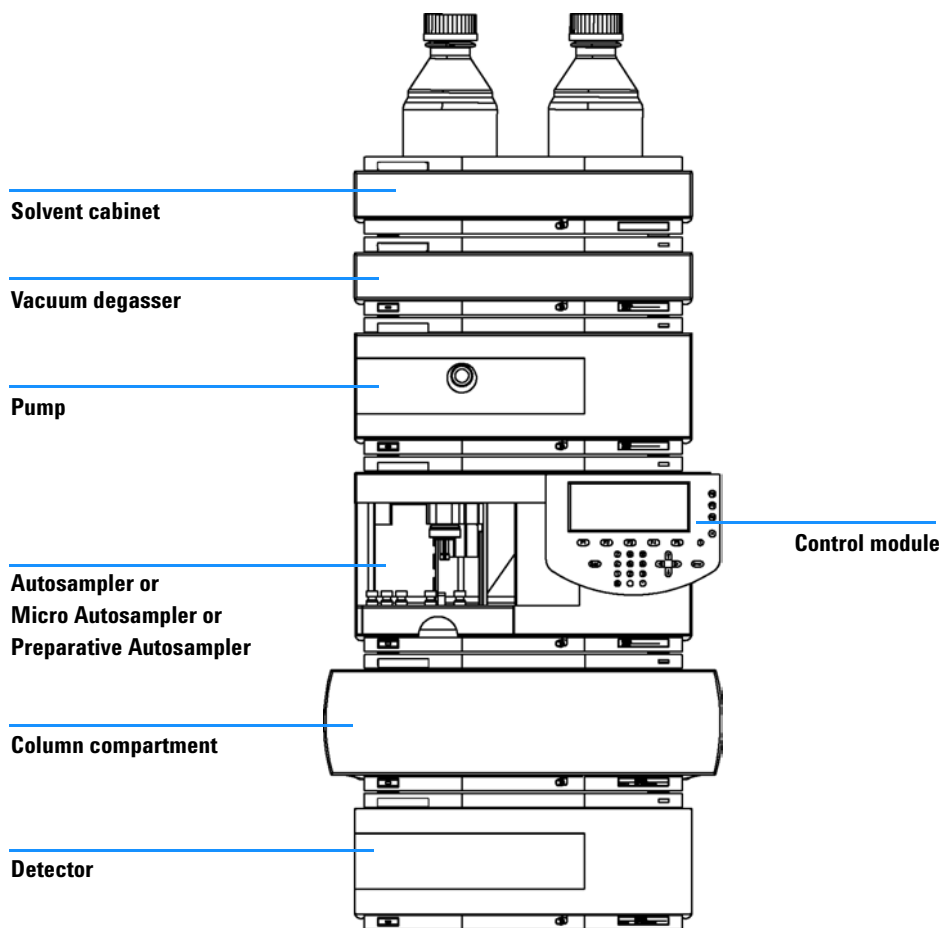
\* Reorder gives pack of 15

**Table 5** G2260A - Preparative Autosampler Accessory Kit Contents G2260-68705

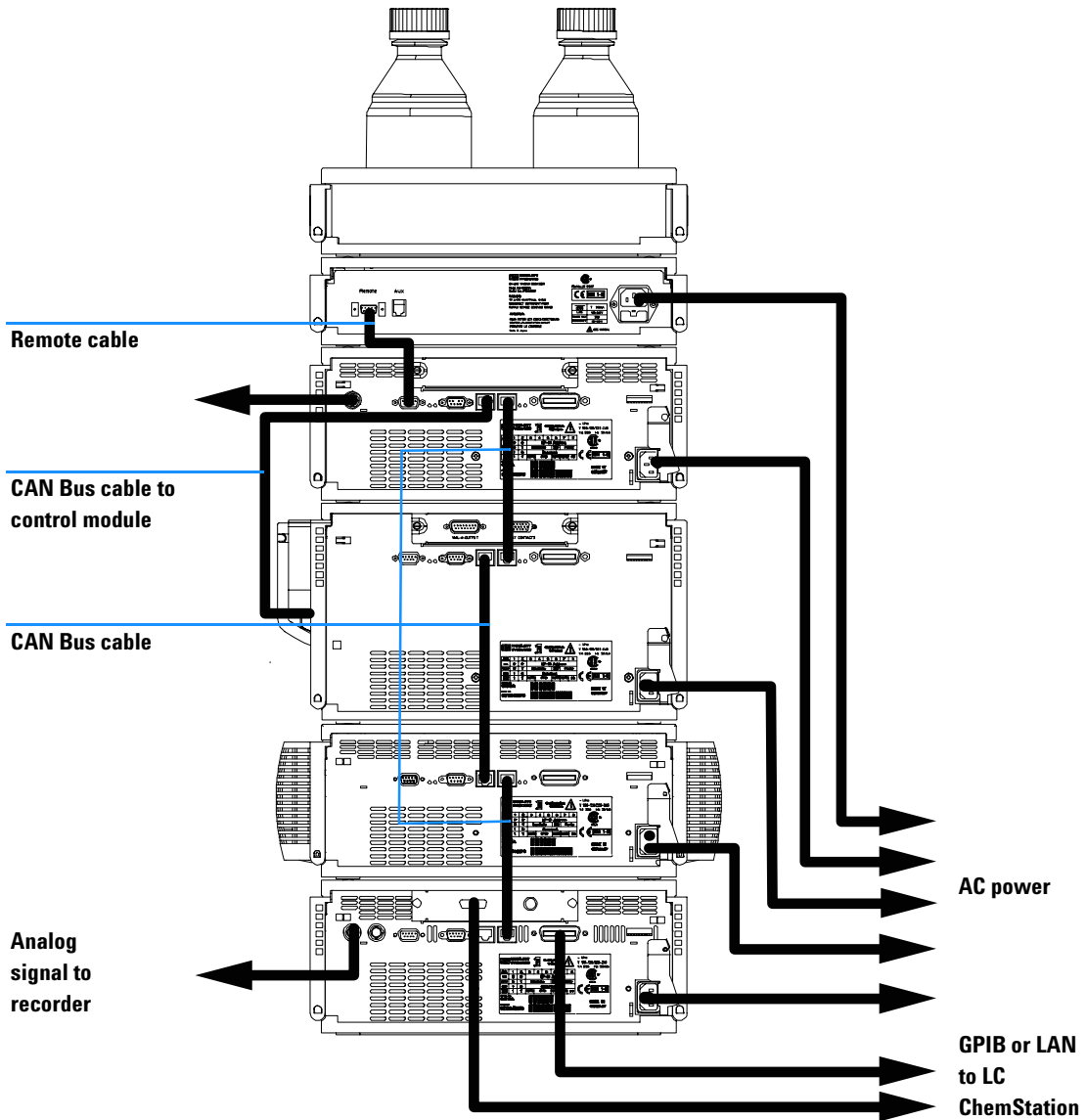
<b>Description</b>	<b>Part Number</b>
Tubing assembly	5063-6527
Filter promo kit	5064-8240
CAN cable, 1 m long	5181-1519
Screw cap vials, clear 100/pk	5182-0714
Blue screw caps 100/pk	5182-0717
Label halftray	5989-3890
Wrenches 1/4 - 5/16 inch	8710-0510
Rheotool socket wrench 1/4 inch	8710-2391
Hex key 4 mm, 15 cm long, T-handle	8710-2392
Hex key 9/64 mm, 15 cm long, T-handle	8710-2394
Hex key 2.5 mm, 15 cm long, straight handle	8710-2412
ESD wrist strap	9300-1408
Finger caps x3 (reorder gives pack of 15)	5063-6506
Front door cooled autosampler	G1329-40301
Air channel adapter	G1329-43200
Tray for 15 x 6 ml vials (x2)	G1313-44503
Union, loop extension	5022-2133
Seat extension capillary (500 µl)	G1313-87307
Seat extension capillary (1500 µl)	G1313-87308
Sampler - Column capillary	G2260-87300

## Optimizing the Stack Configuration

If your autosampler is part of a system, you can ensure optimum performance by installing the autosampler in the stack in the position shown in [Figure 1](#) on page 22 and [Figure 2](#) on page 23. [Figure 3](#) on page 24 and [Figure 4](#) on page 25 show the configuration recommended for a thermostatted autosampler. These configurations optimize the system flow path, ensuring minimum delay volume.

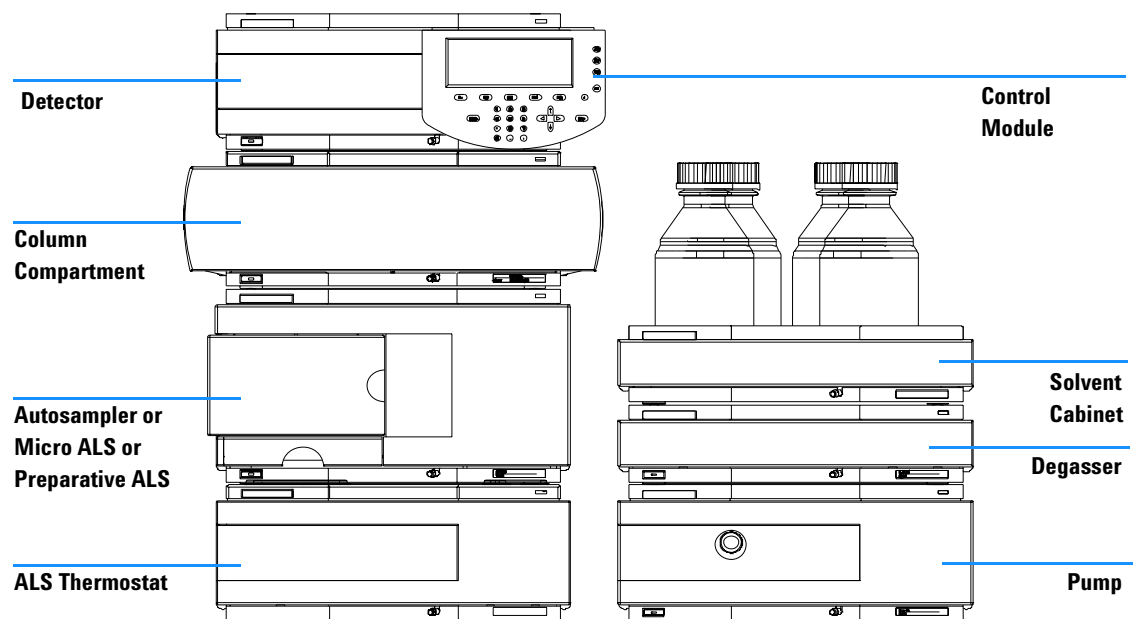


**Figure 1** Recommended Stack Configuration for an Autosampler (Front View)



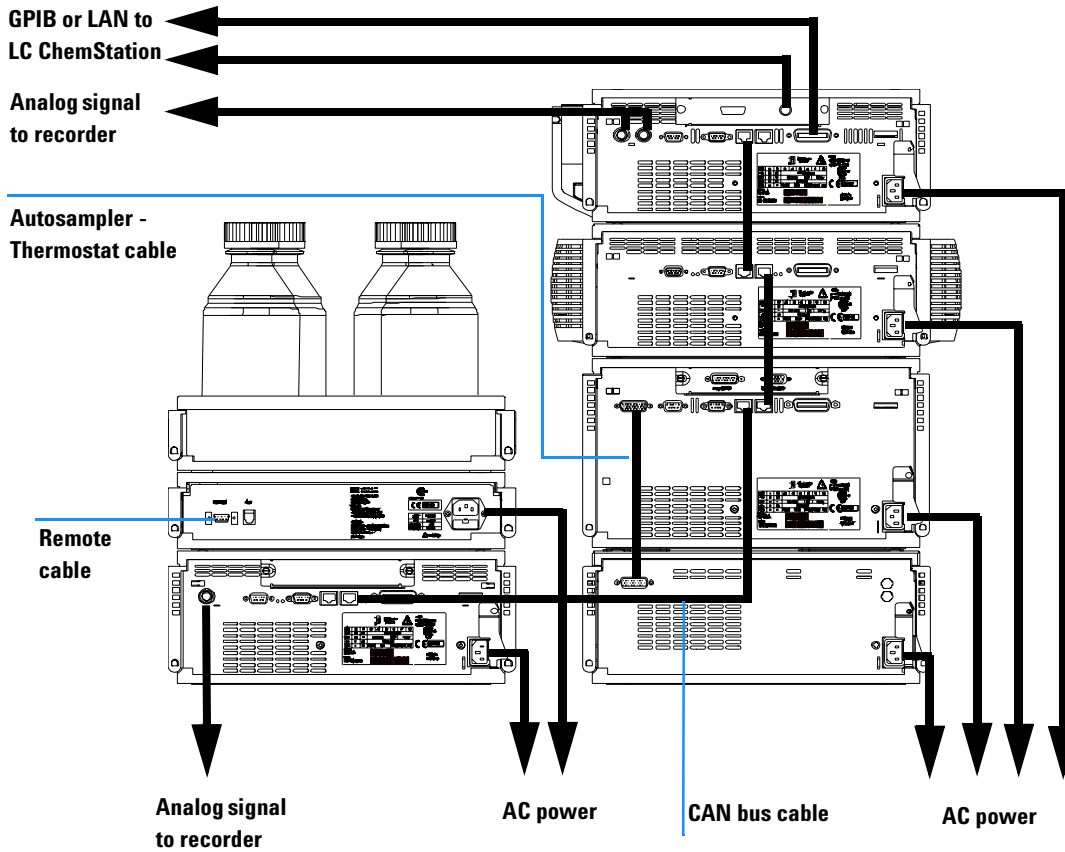
**Figure 2** Recommended Stack Configuration for an Autosampler (Rear View)

## 1 Installing the Autosampler



**Figure 3** Recommended Stack Configuration for a Thermostatted ALS (Front View)





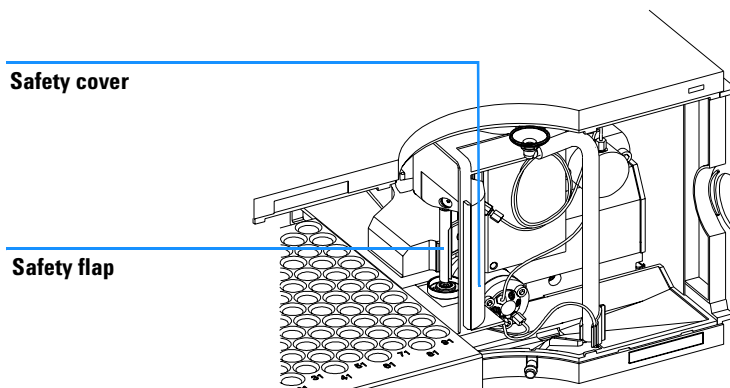
**Figure 4** Recommended Stack Configuration for a Thermostatted ALS (Rear View)

# Installing the Autosampler

<b>Preparation</b>	Locate bench space Provide power connection
<b>Parts required</b>	Unpack the Sampler Sampler Power cord, for the other cables see below and " <a href="#">Cable Overview</a> " on page 194 Chemstation and/or Control Module G1323B.

### WARNING

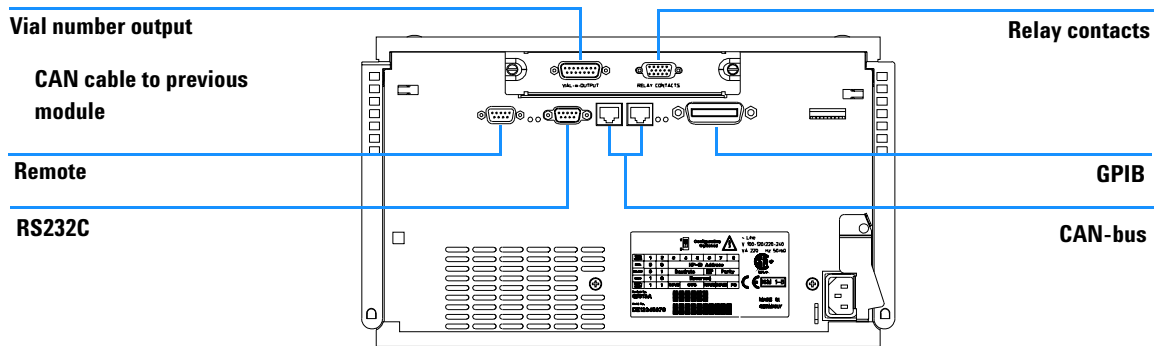
To avoid personal injury, keep fingers away from the needle area during autosampler operation. Do not bend the safety flap away from its position, or attempt to remove the safety cover (see [Figure 5](#)). Do not attempt to insert or remove a vial from the gripper when the gripper is positioned below the needle.



**Figure 5** Safety Flap

- 1 Install the LAN interface board in the sampler (if required), see "[Agilent 1100 Series Interface Board to general purposes](#)" on page 210.
- 2 Remove the adhesive tape which covers the front door.
- 3 Remove the front door and remove the transport protection foam.

- 4 Place the Autosampler on the bench or in the stack as recommended in "Recommended Stack Configuration for an Autosampler (Front View)" on page 22.
- 5 Ensure the power switch at the front of the Autosampler is OFF.
- 6 Connect the power cable to the power connector at the rear of the sampler.
- 7 Connect the CAN cable to the other Agilent 1100 modules.
- 8 If an Agilent Chemstation is the controller, connect either
  - The GPIB cable to the detector
  - The LAN connector to the LAN interface
- 9 Connect the APG remote cable (optional) for non Agilent 1100 series instruments.
- 10 Turn ON power by pushing the button at the lower left hand side of the sampler.



**Figure 6** Cable Connections

**NOTE**

If the front cover is not installed the autosampler is in a not ready condition and operation is inhibited.

## 1 Installing the Autosampler

### NOTE

The sampler is turned ON when the line power switch is pressed and the green indicator lamp is illuminated. The detector is turned OFF when the line power switch is protruding and the green light is OFF.

---

### WARNING

**To disconnect the sampler from the line,unplug the power cord. The power will supply still uses some power, even switch at the front panel is turned OFF.**

---

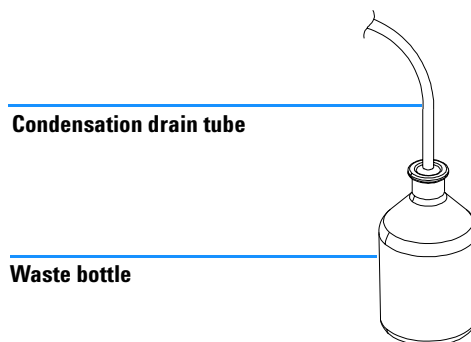
## Installing the Thermostatted Autosampler

<b>Preparation</b>	Locate bench space Provide power connection
<b>Parts required</b>	Unpack the Sampler and the Thermostat Sampler and Thermostat Power cord, for the other cables see below and " <a href="#">Cable Overview</a> " on page 194 Chemstation and/or Control Module G1323B.

- 1 Place the Thermostat on the bench.
- 2 Remove the front cover and route the condensation drain tube to the waste.

### WARNING

**Make sure that the condensation tube is always above the liquid level in the vessel. If the tube is located in liquid the condensed water cannot flow out of the tube and the outlet is blocked. Any further condensation will then remain in the instrument. This may damage the instruments electronics.**

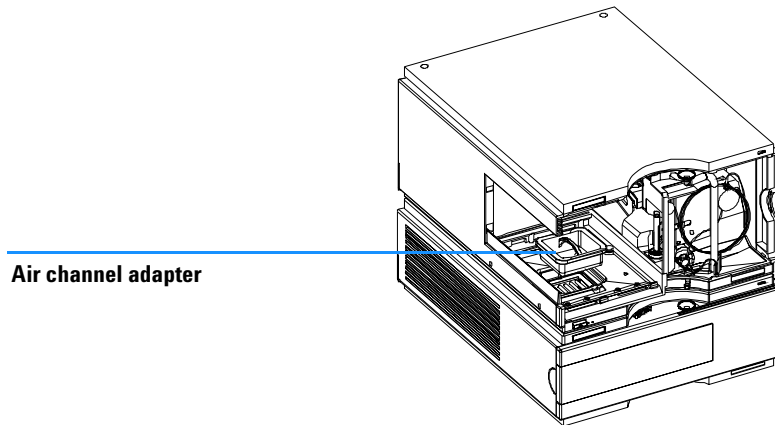


**Figure 7** Condensation Leak outlet

- 3 Install the LAN interface board in the sampler (if required), see "[Agilent 1100 Series Interface Board to general purposes](#)" on page 210.
- 4 Remove the adhesive tape which covers the front door.
- 5 Remove the front door and remove the transport protection foam.

## 1 Installing the Autosampler

- 6 Place the Autosampler on top of the Thermostat. Make sure that the Autosampler is correctly engaged in the Thermostat locks.
- 7 Place the air channel adapter into the autosampler tray base. Make sure the adapter is fully pressed down. This assures that the cold airstream from the Thermostat is correctly guided to the tray area of the Autosampler.



**Figure 8** Air channel adapter

- 8 Re-install the tray
- 9 Ensure the power switch on the front of the Autosampler is OFF and the power cables are disconnected.
- 10 Connect the cable between the Autosampler and the Thermostat, see [Figure 9](#) on page 32.

### **WARNING**

**Do not disconnect or reconnect the autosampler to ALS thermostat cable when the power cords are connected to either of the two modules. This will damage the electronics of the modules.**

- 11 Connect the power cables to the power connectors.
- 12 Connect the CAN cable to the other Agilent 1100 modules.

**13** If an Agilent Chemstation is the controller, connect either

- The GPIB cable to the detector
- The LAN connector to the LAN interface

**14** Connect the APG remote cable (optional) for non Agilent 1100 series instruments.

**15** Turn ON power by pushing the button at the lower left hand side of the sampler.

**NOTE**

The sampler is turned ON when the line power switch is pressed and the green indicator lamp is illuminated. The detector is turned OFF when the line power switch is protruding and the green light is OFF.

---

**WARNING**

**To disconnect the sampler from the line, unplug the power cord. The power supply still uses some power, even if the power switch at the front of the panel is turned OFF.**

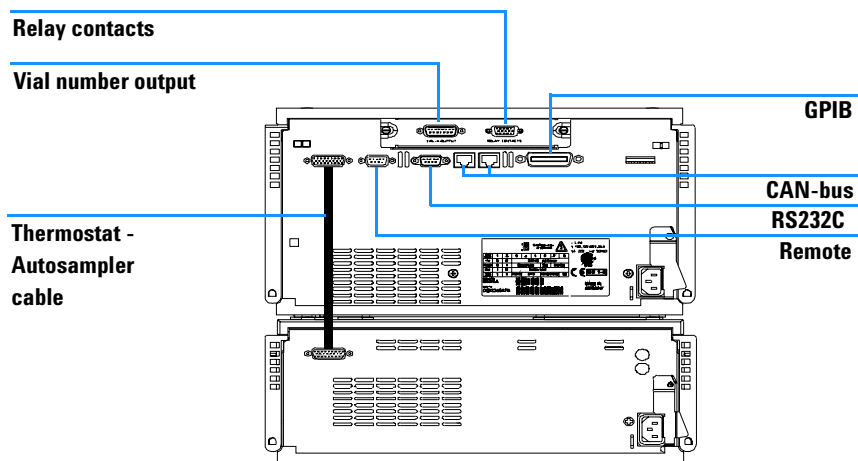
---

**WARNING**

**To avoid personal injury, keep fingers away from the needle area during Autosampler operation. Do not attempt to insert or remove a vial or a plate when the needle is positioned.**

---

## 1 Installing the Autosampler



**Figure 9** Cable Connections



## Flow Connections

**Preparation** Sampler is installed in the LC system  
**Parts required** Parts from the Accessory kit

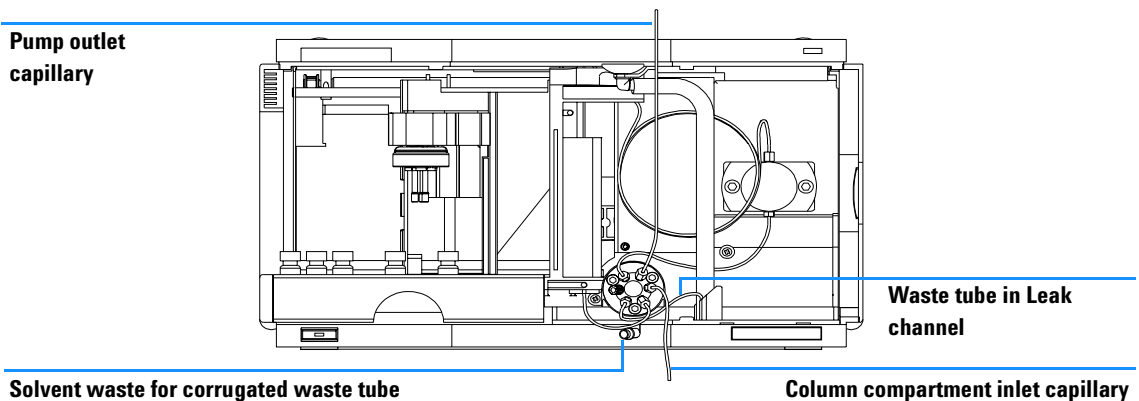
### WARNING

When opening capillary or tube fittings, solvents may leak out. Please observe appropriate safety procedures (for example, goggles, safety gloves and protective clothing) as described in the material handling and safety data sheet supplied by the solvent vendor, especially when toxic or hazardous solvents are used.

- 1 Connect the pump outlet capillary to port 1 of the injection valve.
- 2 Connect column-compartment inlet capillary to port 6 of the injection valve.
- 3 Connect the corrugated waste tube to the solvent waste from the leak plane.
- 4 Ensure that the waste tube is positioned inside the leak channel.

### NOTE

Do not extend the waste capillary of the autosampler. The siphoning effect might empty the complete seat capillary introducing air into the system.



**Figure 10** Hydraulic Connections

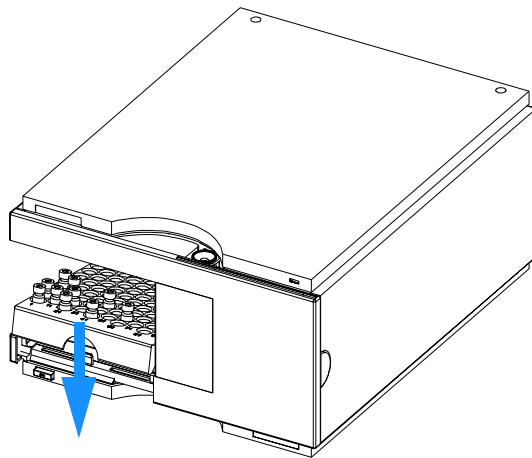
## Sample Trays

### Installing the Sample Tray

- 1 Open the front door.
- 2 Load the sample tray with sample vials as required.
- 3 Slide the sample tray into the autosampler so that the rear of the sample tray is seated firmly against the rear of the sample-tray area.
- 4 Press the front of the sample tray down to secure the tray in the autosampler.

**NOTE**

If the thermostatted autosampler tray pops out of position the air channel adapter is not correctly inserted.



**Figure 11** Installing the Sample Tray

## Supported trays for the different Autosampler

**Table 6** Supported trays for the Autosampler (G1313A)

Description	Part Number
Tray for 100 x 2 ml vials	G1313-44500
Halftray for 15 x 6 ml vials	G1313-44503
Halftray for 40 x 2 ml vials	G1313-44502

**Table 7** Supported tray for the Autosampler (G1329A / G1389A / G2260A)

Description	Part Number
Thermostatable Tray for 100 x 2 ml vials	G1329-60001
Halftray for 15 x 6 ml vials (for G2260A only*)	G1313-44503

\* This tray is not recommended when using a thermostat

## Half-Tray Combinations

Half-trays can be installed in any combination enabling both 2 ml-and 6 ml-vials to be used simultaneously.

## Numbering of Vial Positions

The standard 100-vial tray has vial positions 1 to 100. However, when using two half-trays, the numbering convention is slightly different. The vial positions of the right-hand half tray begin at position 101 as follows:

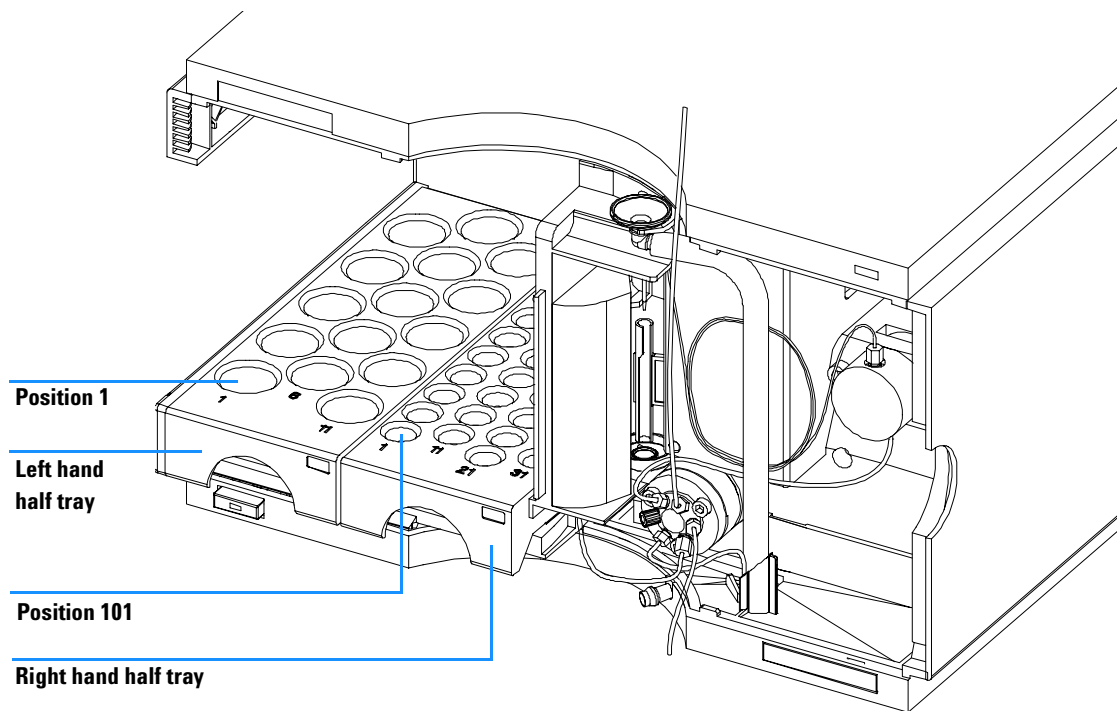
Left-hand 40-position tray: 1 - 40

Left-hand 15-position tray: 1–15

Right-hand 40-position tray: 101–140

Right-hand 15-position tray: 101–115

## 1 Installing the Autosampler



**Figure 12** Numbering of Tray Positions

## Choice of Vials and Caps

### List of Compatible Vials and Caps

For reliable operation vials used with the Agilent 1100 Series autosampler must not have tapered shoulders or caps that are wider than the body of the vial. The vials in [Table 8](#) on page 37, [Table 9](#) on page 37 and [Table 10](#) on page 38 and caps in [Table 11](#) on page 38, [Table 12](#) on page 38 and [Table 13](#) on page 39 (shown with their Part numbers) have been successfully tested using a minimum of 15,000 injections with the Agilent 1100 Series autosampler.

**Table 8** Crimp Top Vials

Description	Volume (ml)	100/Pack	1000/Pack	100/Pack (silanized)
Clear glass	2	5181-3375	5183-4491	
Clear glass, write-on spot	2	5182-0543	5183-4492	5183-4494
Amber glass, write-on spot	2	5182-3376	5183-4493	5183-4495
Polypropylene, wide opening	1	5182-0567		5183-4496
Polypropylene, wide opening	0.3		9301-0978	

**Table 9** Snap Top Vials

Description	Volume (ml)	100/Pack	1000/Pack	100/Pack (silanized)
Clear glass	2	5182-0544	5183-4504	5183-4507
Clear glass, write-on spot	2	5182-0546	5183-4505	5183-4508
Amber glass, write-on spot	2	5182-0545	5183-4506	5183-4509

## 1 Installing the Autosampler

**Table 10** Screw Top Vials

Description	Volume (ml)	100/Pack	1000/Pack	100/Pack (silanized)
Clear glass	2	5182-0714	5183-2067	5183-2070
Clear glass, write-on spot	2	5182-0715	5183-2068	5183-2071
Amber glass, write-on spot	2	5182-0716	5183-2069	5183-2072

**Table 11** Crimp Caps

Description	Septa	100/Pack
Silver aluminum	Clear PTFE/red rubber	5181-1210
Silver aluminum	Clear PTFE/red rubber	5183-4498 (1000/Pack)
Blue aluminum	Clear PTFE/red rubber	5181-1215
Green aluminum	Clear PTFE/red rubber	5181-1216
Red aluminum	Clear PTFE/red rubber	5181-1217

**Table 12** Snap Caps

Description	Septa	100/Pack
Clear polypropylene	Clear PTFE/red rubber	5182-0550
Blue polypropylene	Clear PTFE/red rubber	5182-3458
Green polypropylene	Clear PTFE/red rubber	5182-3457
Red polypropylene	Clear PTFE/red rubber	5182-3459

**Table 13** Screw Caps

<b>Description</b>	<b>Septa</b>	<b>100/Pack</b>
Blue polypropylene	Clear PTFE/red rubber	5182-0717
Green polypropylene	Clear PTFE/red rubber	5182-0718
Red polypropylene	Clear PTFE/red rubber	5182-0719
Blue polypropylene	Clear PTFE/silicone	5182-0720
Green polypropylene	Clear PTFE/silicone	5182-0721
Red polypropylene	Clear PTFE/silicone	5182-0722

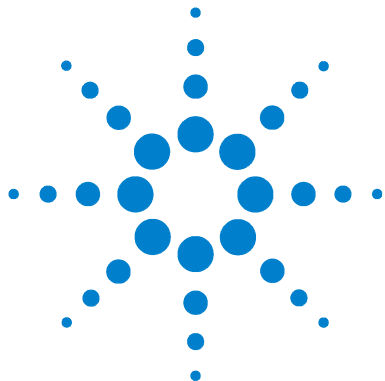
### Transporting the Autosampler

When moving the autosampler around the laboratory, no special precautions are needed. However, if the autosampler needs to be shipped to another location via carrier, ensure:

- The transport assembly is parked (see [“Park Arm \(Park Gripper\)”](#) on page 87);
- The vial tray is secured.

If the autosampler is to be shipped to another location, the transport assembly must be moved to the park position to prevent mechanical damage should the shipping container be subjected to excessive shock. Also, ensure the vial tray is secured in place with suitable packaging, otherwise the tray may become loose and damage internal components.





## 2 Optimizing Performance

Optimization for Lowest Carry-over	42
Fast Injection Cycle and Low Delay Volume	46
Precise Injection Volume	48
Choice of Rotor Seal	50



### Optimization for Lowest Carry-over

Several parts of an injection system can contribute to carry-over:

- needle outside
- needle inside
- needle seat
- sample loop
- seat capillary
- injection valve

The autosampler continuous flow-through design ensures that sample loop, needle inside, seat capillary, and the mainpass of the injection valve is always in the flow line. These parts are continuously flushed during an isocratic and also during a gradient analysis. The residual amount of sample remaining on the outside of the needle after injection may contribute to carry-over in some instances. When using small injection volumes or when injecting samples of low concentration immediately after samples of high concentration, carry-over may become noticeable. Using the automated needle wash enables the carry-over to be minimized and prevents also contamination of the needle seat.

## Using the Automated Needle Wash

The automated needle wash can be programmed either as “injection with needle wash” or the needle wash can be included into the injector program. When the automated needle wash is used, the needle is moved into a wash vial after the sample is drawn. By washing the needle after drawing a sample, the sample is removed from the surface of the needle immediately.

### Uncapped Wash Vial

For best results, the wash vial should contain solvent in which the sample components are soluble, and the vial should *not* be capped. If the wash vial is capped, small amounts of sample remain on the surface of the septum, which may be carried on the needle to the next sample.

### Injector Program with Needle Wash

The injector program includes the command NEEDLE WASH. When this command is included in the injector program, the needle is lowered once into the specified wash vial before injection.

For example:

```
1 DRAW 5 µl
2 NEEDLE WASH vial 7
3 INJECT
```

Line 1 draws 5 µl from the current sample vial. Line 2 moves the needle to vial 7. Line 3 injects the sample (valve switches to main pass).

### Using an Injector Program

The process is based on a program that switches the bypass groove of the injection valve into the flow line for cleaning. This switching event is performed at the end of the equilibration time to ensure that the bypass groove is filled with the start concentration of the mobile phase. Otherwise the separation could be influenced, especially if microbore columns are used.

#### For example:

Outside wash of needle before injection: 14 sec. using flush port

Injector program:

Draw x.x (y)  $\mu\text{l}$  from sample

Needle wash as method

Inject

Wait (equilibration time - see text above)

Valve bypass

Wait 0.2 min

Valve mainpass

Valve bypass

Valve mainpass

#### NOTE

Overlapped injection together with additional injection valve switching is not possible.

---

## General Recommendation to Lowest Carry-over

- For samples where needle outside cannot be cleaned sufficiently with water or alcohol use wash vials with an appropriate solvent. Using an injector program and several wash vials can be used for cleaning.

In case the needle seat has got contaminated and carry-over is significantly higher than expected, the following procedure can be used to clean the needle seat:

- Go to MORE INJECTOR and set needle to home position.
- Pipette an appropriate solvent on to the needle seat. The solvent should be able to dissolve the contamination. If this is not known use 2 or 3 solvents of different polarity. Use several milliliters to clean the seat.
- Clean the needle seat with a tissue and remove all liquid from it.
- RESET the injector.

### Fast Injection Cycle and Low Delay Volume

Short injection cycle times for high sample throughput is one of the main issues in analytical laboratories. Shortening cycle time starts with:

- shortening column length
- high flow rate
- steep gradient

Having optimized these parameters, further reduction of cycle times can be obtained using the overlapped injection mode.

#### Overlapped Injection Mode

In this process, as soon as the sample has reached the column, the injection valve is switched back to bypass and the next injection cycle starts but waits with switching to mainpass until the actual run is finished. You gain the sample preparation time when using this process.

Switching the valve into the bypass position reduces the system delay volume, the mobile phase is directed to the column without passing sample loop, needle and needle seat capillary. This can help to have faster cycle times especially if low flow rates have to be used like it is mandatory in narrow bore and micro bore HPLC.

#### NOTE

Having the valve in bypass position can increase the carry-over in the system.

---

The injection cycle times also depend on the injection volume. In identically standard condition, injecting 100  $\mu\text{l}$  instead of 1  $\mu\text{l}$ , increase the injection time by approximately 8 sec. In this case and if the viscosity of the sample allows it, the draw and eject speed of the injection system has to be increased.

**NOTE**

For the last injection of the sequence with overlapped injections it has to be considered that for this run the injection valve is not switched as for the previous runs and consequently the injector delay volume is not bypassed. This means the retention times are prolonged for the last run. Especially at low flow rates this can lead to retention time changes which are too big for the actual calibration table. To overcome this it is recommended to add an additional “blank” injection as last injection to the sequence.

---

### **General Recommendations for Fast Injection Cycle Times**

As described in this section, the first step to provide short cycle times are optimizing the chromatographic conditions. If this is done the autosampler parameter should be set to:

- Overlapped injection mode
- Increase of draw and eject speed for large injection volumes
- Add at last run a blank, if overlapped injection is used

To reduce the injection time, the detector balance has to be set to OFF.

### Precise Injection Volume

**Injection Volumes Less Than 2  $\mu\text{l}$**  When the injection valve switches to the BYPASS position, the mobile phase in the sample loop is depressurized. When the syringe begins drawing sample, the mobile phase is further subjected to decreasing pressure. If the mobile phase is not adequately degassed, small gas bubbles may form in the sample loop during the injection sequence. When using injection volumes  $< 2 \mu\text{l}$ , these gas bubbles may affect the injection-volume precision. For best injection-volume precision with injection volumes  $< 2 \mu\text{l}$ , use of the Agilent 1100 Series degasser is recommended to ensure the mobile phase is adequately degassed. Also, using the automated needle wash (see [“Optimization for Lowest Carry-over”](#) on page 42) between injections reduces carry-over to a minimum, improving injection-volume precision further.

### Draw and Eject Speed

#### Draw Speed

The speed at which the metering unit draws sample out of the vial may have an influence on the injection volume precision when using viscous samples. If the draw speed is too high, air bubbles may form in the sample plug, affecting precision. The default draw speed is 200  $\mu\text{l}/\text{min}$  for the autosampler, 4  $\mu\text{l}/\text{min}$  for the micro autosampler and 1000  $\mu\text{l}/\text{min}$  for the preparative autosampler. This speed is suitable for the majority of applications, however, when using viscous samples, set the draw speed to lower speed for optimum results. A “DRAW” statement in an injector program also uses the draw speed setting which is configured for the autosampler.



### Eject Speed

The default eject speed setting is 200  $\mu\text{l}/\text{min}$  for the autosampler, 10  $\mu\text{l}/\text{min}$  for the micro autosampler and 1000  $\mu\text{l}/\text{min}$  for the preparative autosampler. When using large injection volumes, setting the eject speed to a higher value speeds up the injection cycle by shortening the time the metering unit requires to eject solvent at the beginning of the injection cycle (when the plunger returns to the home position).

An “EJECT” statement in an injector program also uses the eject speed setting which is configured for the autosampler. A faster eject speed shortens the time required to run the injector program. When using viscous samples, a high eject speed should be avoided.

### Choice of Rotor Seal

#### **Vespel™ Seal (for standard and micro valves only)**

The standard seal has sealing material made of Vespel. Vespel is suitable for applications using mobile phases within the pH range of 2.3 to 9.5, which is suitable for the majority of applications. However, for applications using mobile phases with pH below 2.3 or above 9.5, the Vespel seal may degrade faster, leading to reduced seal lifetime.

#### **Tefzel™ Seal (for standard valve only)**

For mobile phases with pH below 2.3 or above 9.5, or for conditions where the lifetime of the Vespel seal is drastically reduced, a seal made of Tefzel is available (see [“Injection-Valve Assembly”](#) on page 177). Tefzel is more resistant than Vespel to extremes of pH, however, is a slightly *softer* material. Under normal conditions, the expected lifetime of the Tefzel seal is shorter than the Vespel seal, however, Tefzel may have the longer lifetime under more extreme mobile phase conditions.

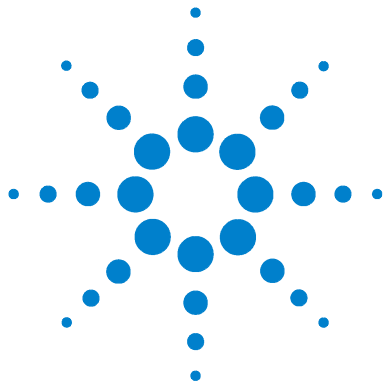
#### **PEEK Seal (for preparative injection valve only)**

The preparative injection valve has a sealing material made of PEEK. This material has high chemical resistance and versatility. It is suitable for application using mobile phases within a pH between 1 and 14.

#### **NOTE**

Strong oxidizing acids such as concentrated nitric and sulfuric acids are not compatible with PEEK.

---



## 3 Troubleshooting and Test Functions

Overview of the Sampler's Indicators and Test Functions	52
Status Indicators	53
Error Messages	55
Maintenance Functions	82
Step Commands	91
Troubleshooting	93



## Overview of the Sampler's Indicators and Test Functions

### Status Indicators

The autosamplers are provided with two status indicators which indicate the operational state (prerun, run, and error states) of the instrument. The status indicators provide a quick visual check of the operation of the autosampler (see ["Status Indicators"](#) on page 53).

### Error Messages

In the event of an electronic, mechanical or hydraulic failure, the instrument generates an error message in the user interface. For each message, a short description of the failure, a list of probable causes of the problem, and a list of suggested actions to fix the problem are provided (see ["Error Messages"](#) on page 55).

### Maintenance Functions

The maintenance functions position the needle arm, gripper assembly, and metering device for easy access when doing maintenance (see ["Maintenance Functions"](#) on page 82).

### Tray Alignment

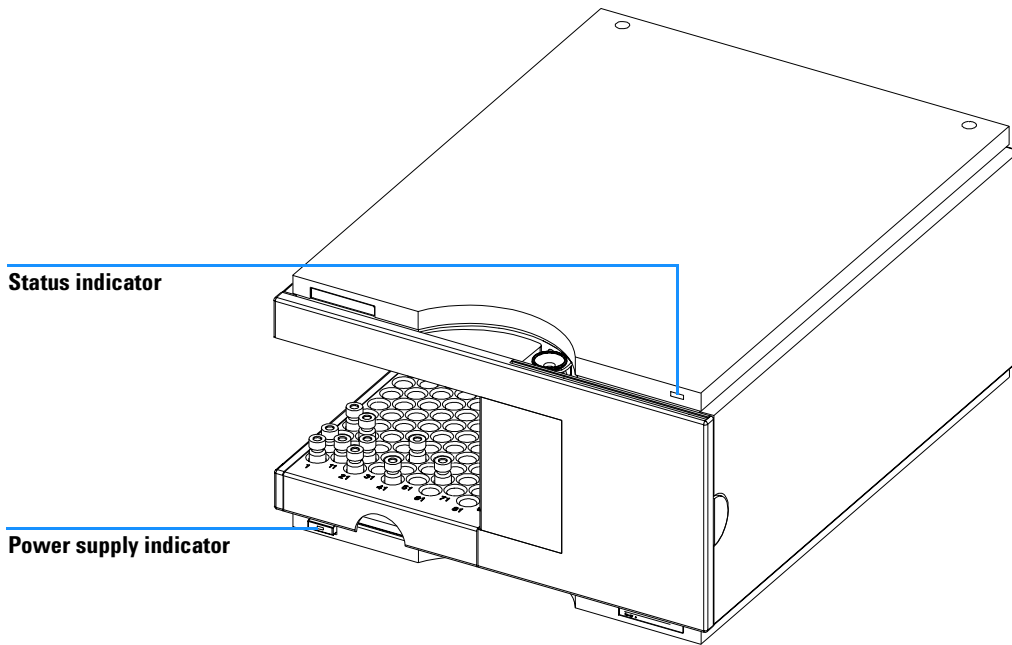
Tray alignment is required after repair of internal components, or after a firmware update. The procedure aligns the gripper arm correctly to ensure the positioning of the gripper arm is correct for all vials (see ["Tray Alignment"](#) on page 89).

### Step Commands

The step functions provide the possibility to execute each step of the sampling sequence individually. The step functions are used primarily for troubleshooting, and for verification of correct autosampler operation after repair (see ["Step Commands"](#) on page 91).

## Status Indicators

Two status indicators are located on the front of the autosampler. The lower left indicates the power supply status, the upper right indicates the autosampler status.



**Figure 13** Location of Status Indicators

### Power Supply Indicator

The power supply indicator is integrated into the main power switch. When the indicator is illuminated (*green*) the power is ON.

## Instrument Status Indicator

The instrument status indicator indicates one of four possible instrument conditions:

- When the status indicator is *OFF* (and power switch light is on), the instrument is in a *prerun* condition, and is ready to begin an analysis.
- A *green* status indicator, indicates the instrument is performing an analysis (*run* mode).
- A *yellow* indicator indicates a *not-ready* condition. The instrument is in a not-ready state when it is waiting for a specific condition to be reached or completed (for example, front cover not installed), or while a self-test procedure is running.
- An *error* condition is indicated when the status indicator is *red*. An error condition indicates the instrument has detected an internal problem which affects correct operation of the instrument. Usually, an error condition requires attention (for example, leak, defective internal components). An error condition always interrupts the analysis.

## Error Messages

Error messages are displayed in the user interface when an electronic, mechanical, or hydraulic (flow path) failure occurs which requires attention before the analysis can be continued (for example, repair, exchange of consumables is necessary). In the event of such a failure, the red status indicator at the front of the module is switched on, and an entry is written into the instrument log book.

This section describes the meaning of autosampler error messages, and provides information on probable causes and suggested actions how to recover from error conditions.

### Timeout

The timeout threshold was exceeded.

#### Probable Causes

- The analysis was completed successfully, and the timeout function switched off the pump as requested.
- A not-ready condition was present during a sequence or multiple-injection run for a period longer than the timeout threshold.

#### Suggested Actions

- ✓ Check the logbook for the occurrence and source of a not-ready condition. Restart the analysis where required.



## Shutdown

An external instrument has generated a shut-down signal on the remote line.

The autosampler continually monitors the remote input connectors for status signals. A LOW signal input on pin 4 of the remote connector generates the error message.

### Probable Causes

- Leak detected in an external instrument with a remote connection to the system.
- Shut-down in an external instrument with a remote connection to the system.
- The degasser failed to generate sufficient vacuum for solvent degassing.

### Suggested Actions

- ✓ Fix the leak in the external instrument before restarting the autosampler.
- ✓ Check external instruments for a shut-down condition.
- ✓ Check the degasser for an error condition. Refer to the *Reference Manual* for the Agilent 1100 Series degasser.

## Remote Timeout

A not-ready condition is still present on the remote input.

When an analysis is started, the system expects all not-ready conditions (e.g. a not-ready condition during detector balance) to switch to run conditions within one minute of starting the analysis. If a not-ready condition is still present on the remote line after one minute the error message is generated.

### Probable Causes

- Not-ready condition in one of the instruments connected to the remote line.
- Defective remote cable.
- Defective components in the instrument showing the not-ready condition.

### Suggested Actions

- ✓ Ensure the instrument showing the not-ready condition is installed correctly, and is set up correctly for analysis.
- ✓ Exchange the remote cable.
- ✓ Check the instrument for defects (refer to the instrument's reference documentation).

## Synchronization Lost

During an analysis, the internal synchronization or communication between one or more of the modules in the system has failed.

The system processors continually monitor the system configuration. If one or more of the modules is no longer recognized as being connected to the system, the error message is generated.

### Probable Causes

- CAN cable disconnected.
- Defective CAN cable.
- Defective main board in another module.

### Suggested Actions

- ✓ Ensure all the CAN cables are connected correctly.
- ✓ Switch off the system. Restart the system, and determine which module or modules are not recognized by the system.
- ✓ Ensure all CAN cables are installed correctly.

## Leak

A leak was detected in the autosampler.

The signals from the two temperature sensors (leak sensor and board-mounted temperature-compensation sensor) are used by the leak algorithm to determine whether a leak is present. When a leak occurs, the leak sensor is cooled by the solvent. This changes the resistance of the leak sensor which is sensed by the leak-sensor circuit on the ASM board.

### Probable Causes

- Loose fittings.
- Broken capillary.
- Leaking rotor seal or needle seat.
- Defective metering seal.

### Suggested Actions

- ✓ Ensure all fittings are tight.
- ✓ Exchange defective capillaries.
- ✓ Exchange the rotor seal or seat capillary.
- ✓ Exchange the metering seal.

## Leak Sensor Open

The leak sensor in the autosampler has failed (open circuit).

The current through the leak sensor is dependent on temperature. A leak is detected when solvent cools the leak sensor, causing the leak-sensor current to change within defined limits. If the current falls outside the lower limit, the error message is generated.

### Probable Causes

- Leak sensor not connected to the ASM board.
- Defective leak sensor.

### Suggested Actions

- ✓ Ensure the leak sensor is connected correctly.
- ✓ Exchange the leak sensor.

## Leak Sensor Short

The leak sensor in the autosampler has failed (short circuit).

The current through the leak sensor is dependent on temperature. A leak is detected when solvent cools the leak sensor, causing the leak-sensor current to change within defined limits. If the current increases above the upper limit, the error message is generated.

### Probable Causes

- Defective leak sensor.

### Suggested Actions

- ✓ Exchange the leak sensor.

## Compensation Sensor Open

The ambient-compensation sensor (NTC) on the ASM board in the autosampler has failed (open circuit).

The resistance across the temperature compensation sensor (NTC) on the ASM board is dependent on ambient temperature. The change in resistance is used by the leak circuit to compensate for ambient temperature changes. If the resistance across the sensor increases above the upper limit, the error message is generated.

### Probable Causes

- Defective ASM board.

### Suggested Actions

- ✓ Exchange the ASM board.

## Compensation Sensor Short

The ambient-compensation sensor (NTC) on the ASM board in the autosampler has failed (short circuit).

The resistance across the temperature compensation sensor (NTC) on the ASM board is dependent on ambient temperature. The change in resistance is used by the leak circuit to compensate for ambient temperature changes. If the resistance across the sensor falls below the lower limit, the error message is generated.

### Probable Causes

- Defective ASM board.

### Suggested Actions

- ✓ Exchange the ASM board.



## Fan Failed

The cooling fan in the autosampler has failed.

The hall sensor on the fan shaft is used by the ASM board to monitor the fan speed. If the fan speed falls below 2 revolutions/second for longer than 5 seconds, the error message is generated.

### Probable Causes

- Fan cable disconnected.
- Defective fan.
- Defective ASM board.

### Suggested Actions

- ✓ Ensure the fan is connected correctly.
- ✓ Exchange fan.
- ✓ Exchange the ASM board.

#### Open Cover

The top foam has been removed.

The sensor on the ASM board detects when the top foam is in place. If the foam is removed, the fan is switched off, and the error message is generated.

#### Probable Causes

- The top foam was removed during operation.
- Foam not activating the sensor.
- Sensor defective.

#### Suggested Actions

- ✓ Replace the top foam.
- ✓ Exchange the ASM board.

## Restart Without Cover

The autosampler was restarted with the top cover and foam open.

The sensor on the ASM board detects when the top foam is in place. If the autosampler is restarted with the foam removed, the autosampler switches off within 30 s, and the error message is generated.

### Probable Causes

- autosampler started with the top cover and foam removed.

### Suggested Actions

- ✓ Replace the top cover and foam.

## Arm Movement Failed

The transport assembly was unable to complete a movement in one of the axes.

The processor defines a certain time window for the successful completion of a movement in any particular axis. The movement and position of the transport assembly is monitored by the encoders on the stepper motors. If the processor does not receive the correct position information from the encoders within the time window, the error message is generated.

See figure “[Transport Assembly](#)” on page 222 for axes identification.

**Arm Movement 0 Failed:** X-axis.

**Arm Movement 1 Failed:** Z-axis.

**Arm Movement 2 Failed:** Theta (gripper rotation).

**Arm Movement 3 Failed:** Gripper (gripper fingers open/close).

### Probable Causes

- Mechanical obstruction.
- High friction in transport assembly.
- Defective motor assembly.
- Defective transport assembly flex board.
- Defective ASM board.

### Suggested Actions

- ✓ Ensure unobstructed movement of the transport assembly.
- ✓ Exchange the transport assembly.
- ✓ Exchange the ASM board.

## Valve to Bypass Failed

The injection valve failed to switch to the bypass position.

The switching of the injection valve is monitored by two microswitches on the valve assembly. The switches detect the successful completion of the valve movement. If the valve fails to reach the bypass position, or if the microswitch does not close, the error message is generated.

### Probable Causes

- Defective injection valve.
- Defective ASM board.

### Suggested Actions

- ✓ Exchange the injection valve.
- ✓ Exchange the ASM board.

## Valve to Mainpass Failed

The injection valve failed to switch to the mainpass position.

The switching of the injection valve is monitored by two microswitches on the valve assembly. The switches detect the successful completion of the valve movement. If the valve fails to reach the mainpass position, or if the microswitch does not close, the error message is generated.

### Probable Causes

- Defective injection valve.
- Defective ASM board.

### Suggested Actions

- ✓ Exchange the injection valve.
- ✓ Exchange the ASM board.

## Needle Up Failed

The needle arm failed to move successfully from the seat or out of the vial to the upper position.

The upper position of the needle arm is monitored by a position sensor on the sampling unit flex board. The sensor detects the successful completion of the needle movement to the upper position. If the needle fails to reach the end point, or if the sensor fails to recognize the needle arm movement, the error message is generated.

### Probable Causes

- Defective or dirty position sensor.
- Defective motor.
- Sticking spindle assembly.
- Defective ASM board.

### Suggested Actions

- ✓ Exchange the sampling unit flex board.
- ✓ Exchange the needle drive motor.
- ✓ Exchange the spindle assembly or sampling unit assembly.
- ✓ Exchange ASM board.

## Needle Down Failed

The needle arm failed to move down into the needle seat.

The lower position of the needle arm is monitored by a position sensor on the sampling unit flex board. The sensor detects the successful completion of the needle movement to the needle seat position. If the needle fails to reach the end point, or if the sensor fails to recognize the needle arm movement, the error message is generated.

### Probable Causes

- Needle installed incorrectly, or wrong needle type (too long).
- Defective or dirty position sensor.
- Defective motor.
- Sticking spindle assembly.
- Defective ASM board.

### Suggested Actions

- ✓ Ensure the correct needle type is used, and installed correctly.
- ✓ Exchange the sampling unit flex board.
- ✓ Exchange the needle drive motor.
- ✓ Exchange the spindle assembly or sampling unit assembly.
- ✓ Exchange the ASM board.



## Missing Vial

No vial was found in the position defined in the method or sequence.

When the gripper arm picks a vial out of the sample tray, the processor monitors the gripper motor encoder. If a vial is present, the closing of the gripper fingers is limited by the vial. However, if no vial is present, the gripper fingers close too far. This is sensed by the processor (encoder position), causing the error message to be generated.

### Probable Causes

- No vial in the position defined in the method or sequence.
- Incorrect gripper alignment.
- Defective gripper assembly (defective gripper fingers or belt).
- Defective transport assembly flex board.

### Suggested Actions

- ✓ Install the sample vial in the correct position, or edit the method or sequence accordingly.
- ✓ Align gripper.
- ✓ Exchange the gripper assembly.
- ✓ Exchange the transport assembly.

## Initialization Failed

The autosampler failed to complete initialization correctly.

The autosampler initialization procedure moves the needle arm and transport assembly to their home positions in a predefined sequence. During initialization, the processor monitors the position sensors and motor encoders to check for correct movement. If one or more of the movements is not successful, or is not detected, the error message is generated.

### Probable Causes

- Mechanical obstruction.
- Defective sampling unit flex board.
- Defective transport assembly flex board.
- Defective sampling unit motor.
- Defective ASM board.

### Suggested Actions

- ✓ Ensure unobstructed movement of the transport assembly.
- ✓ Exchange the defective sampling unit motor.
- ✓ Exchange the transport assembly.
- ✓ Exchange the ASM board.

## Metering Home Failed

The metering plunger has failed to move back to the home position.

The home position sensor on the sampling unit flex board monitors the home position of the plunger. If the plunger fails to move to the home position, or if the sensor fails to recognize the plunger position, the error message is generated.

### Probable Causes

- Dirty or defective sensor.
- Broken plunger.
- Defective metering-drive motor.
- Defective ASM board.

### Suggested Actions

- ✓ Exchange the sampling unit flex board.
- ✓ Exchange the metering plunger and seal.
- ✓ Exchange the metering-drive motor.
- ✓ Exchange the ASM board.

## Motor Temperature

One of the motors of the transport assembly has drawn excessive current, causing the motor to become too hot. The processor has switched off the motor to prevent damage to the motor.

See figure “[Transport Assembly](#)” on page 222 for motor identification.

**Motor 0 temperature:** X-axis motor.

**Motor 1 temperature:** Z-axis motor.

**Motor 2 temperature:** Theta (gripper rotation) motor.

**Motor 3 temperature:** Gripper motor (motor for gripper fingers).

The processor monitors the current drawn by each motor and the time the motor is drawing current. The current drawn by the motors is dependent on the load on each motor (friction, mass of components etc.). If the current drawn is too high, or the time the motor draws current is too long, the error message is generated.

### Probable Causes

- Mechanical obstruction.
- High friction in the transport assembly.
- Motor belt tension too high.
- Defective motor.
- Defective transport assembly flex board.

### Suggested Actions

- ✓ Switch off the autosampler at the power switch. Wait at least 10 minutes before switching on again.
- ✓ Ensure unobstructed movement of the transport assembly.
- ✓ Exchange the transport assembly.

## Initialization with Vial

The autosampler attempted to initialize with a vial still in the gripper.

During initialization, the autosampler checks correct operation of the gripper by closing and opening the gripper fingers while monitoring the motor encoder. If a vial is still in the gripper when initialization is started, the gripper fingers cannot close causing the error message to be generated.

### Probable Causes

- Vial still in gripper.

### Suggested Actions

- ✓ Remove the vial using the “Release Vial” function in the user interface. Reinitialize the autosampler.

## Safety Flap Missing

The safety flap was not detected.

Before the needle moves down into the needle seat to inject sample, the safety flap locks into position. Next, and the gripper checks the safety flap by trying to move the safety flap away from the needle. If the gripper is able to move beyond the safety flap position (safety flap not in position), the error message is generated.

### Probable Causes

- Safety flap missing or broken.

### Suggested Actions

- ✓ Exchange the safety flap.

## Vial in Gripper

The gripper arm attempted to move with a vial still in the gripper.

During specific stages of the sampling sequence, no vial should be held by the gripper. The autosampler checks if a sample vial is stuck in the gripper by closing and opening the gripper fingers while monitoring the motor encoder. If the gripper fingers are unable to close, the error message is generated.

### Probable Causes

- Vial still in gripper.

### Suggested Actions

- ✓ Remove the vial using the “Release Vial” function in the user interface. Reinitialize the autosampler.

## Missing Wash Vial

The wash vial programmed in the method was not found.

When the gripper arm picks a vial out of the sample tray, the processor monitors the gripper motor encoder. If a vial is present, the closing of the gripper fingers is limited by the vial. However, if no vial is present, the gripper fingers close too far. This is sensed by the processor (encoder position), causing the error message to be generated.

### Probable Causes

- No wash vial in the position defined in the method.

### Suggested Actions

- ✓ Install the wash vial in the correct position, or edit the method accordingly.



## Invalid Vial Position

The vial position defined in the method or sequence does not exist.

The reflection sensors on the transport assembly flex board are used to check automatically which sample trays are installed (coding on tray). If the vial position does not exist in the current sample tray configuration, the error message is generated.

### Probable Causes

- Incorrect tray or trays installed.
- Incorrect vial positions defined in the method or sequence.
- Tray recognition defective (dirty sample tray or defective transport assembly flex board).

### Suggested Actions

- ✓ Install the correct trays, or edit the method or sequence accordingly.
- ✓ Ensure the coding surfaces of the sample tray are clean (located at the rear of the sample tray).
- ✓ Exchange the transport assembly.

## Maintenance Functions

Certain maintenance procedures require the needle arm, metering device, and gripper assembly to be moved to specific positions to enable easy access to components. The maintenance functions move these assemblies into the appropriate maintenance position. In the ChemStation the ALS maintenance positions can be selected from the Maintenance menu in the Diagnosis display. In the Control Module the functions can be selected in the Test screens of the autosampler.

## User Interface

The functions for the ChemStation and Control Module (different names for functions in the Control Module are shown in brackets) are:

### **Change Needle:**

moves the safety flap away from the needle, and positions the needle arm for easy access to the needle and needle seat.

### **Change Piston:**

relieves the tension on the metering spring (draws the piston to the outer position), enabling easy disassembly of the metering head assembly).

### **Park Arm (Park Gripper):**

secures the gripper arm to the park position behind the sampling unit. ready for transport or shipping of the autosampler.

### **Home:**

moves the tray arm to its home position for better access and exchange of the trays.

### **Change Gripper:**

The change gripper function moves the gripper to the front of the autosampler enabling easy access to the gripper release mechanism.

## Change Needle

### WARNING

For needle exchange, the needle arm moves down automatically when the front cover is removed. To avoid personal injury, keep fingers away from the needle area during needle movement.

---

The change-needle/seat function moves the safety flap out of position, and positions the needle for easy exchange and alignment of the needle and needle seat.

### User Interface

The commands for the ChemStation and Control Module (different names for the commands in the Control Module are shown in brackets) are:

### NOTE

The autosampler front cover must be in place when “Start” and “End” are selected.

---

### Start (Change)

Moves the safety flap away from the needle, and positions the needle approximately 15 mm above the needle seat.

### Needle Up (Up Arrow)

Press function key couple of times to move the needle arm up in 2 mm steps.

### Needle Down (Down Arrow)

Press function key couple of times to move the needle arm down in 2 mm steps. The lowest position (“end position”) is used to align the needle at the correct position in the needle seat.

### End (Done)

Completes the procedure by moving the gripper arm to the home position, and releasing the safety flap.

### Using the Change Needle Function

- 1 Ensure the front cover is installed.
- 2 Select “Start” (“Change”) to move the needle arm to the maintenance position.
- 3 Remove the front cover.

**NOTE**

Do not remove the front cover until the needle arm is in its maintenance position. Removing the cover while the needle arm is activated may lock up the system.

---

- 4 Exchange the needle or needle seat (see “[Needle-Seat Assembly](#)” on page 112 and “[Needle Assembly](#)” on page 109).
- 5 Replace the front cover.
- 6 Select “End” (“Done”) to complete the procedure.

## Change Piston

The change-piston function draws the piston away from the home position, relieving the tension on the spring. In this position, the analytical head assembly can be removed and reinstalled easily after maintenance.

### User Interface

The commands for the ChemStation and Control Module (different names for commands in the Control Module are shown in brackets) are:

#### Start (Change)

Draws the piston away from the home position, relieving the tension on the spring.

#### End (Done)

Repositions the plunger at the home position.

### Using the Change Seal Function

- 1 Select "Start" ("Change") to move the piston to the maintenance position.
- 2 Exchange the metering seal (see "[Gripper Arm](#)" on page 126).
- 3 Select "End" ("Done") to move the piston back to the home position.

## Park Arm (Park Gripper)

### CAUTION

Before transporting or shipping the autosampler, always secure the arm in the park position.

---

In order to prevent mechanical damage to the transport mechanism during transport, the gripper arm should be moved into the park position. The park arm function moves the gripper and transport slider to the home position behind the sampling unit, and lowers the gripper arm into the park position where the transport assembly is secured against a mechanical stop. The autosampler can be switched off after parking the arm.

### NOTE

Before parking the gripper arm, ensure there is no vial in the gripper. Use the “Release Gripper” function to remove the vial.

---

### User Interface

In the ChemStation the Park Arm command is part of the ALS maintenance positions that can be selected from the Maintenance menu in the Diagnosis display. In the Control Module the Park Gripper command is located in the Control display of the autosampler.

The commands for the ChemStation and Control Module (different names for commands in the Control Module are shown in brackets) are:

#### Park Arm (Park Gripper)

moves the gripper arm to the park position.

#### Home

moves the gripper arm out of the park position to the home position.

### Using the Park Arm Function

- 1 Select “Park Arm” (“Park Gripper”).
- 2 When the arm is in the park position, the autosampler is ready for shipment, and can be switched off.

## Change Gripper (Change Arm)

The change gripper function moves the gripper to the front of the autosampler enabling easy access to the gripper release mechanism.

### User Interface

The commands for the ChemStation and Control Module (different names for commands in the Control Module are shown in brackets) are:

### Start (Change)

Moves the transport assembly and gripper arm to the position required to change the gripper arm.

### End (Done)

Repositions the transport assembly and gripper arm to the home position.

### Using the Change Seal Function

- 1 Select "Start" ("Change") to move the gripper arm to the maintenance position.
- 2 Exchange the gripper arm (see "[Gripper Arm](#)" on page 126).
- 3 Select "End" ("Done") to move the gripper arm to the home position.



## Tray Alignment

Tray alignment is required to compensate for small deviations in positioning of the gripper which may occur after disassembling the module for repair.

The tray alignment procedure uses several tray positions as reference points. Because the tray is a rectangle, a two-point alignment is sufficient to corrects all other vial positions within the tray. On completion of the procedure, the corrected gripper positions are stored in the instrument firmware.

### NOTE

The alignment procedure requires an 1100 Control Module G1323B with firmware revision B.02.02 or higher. The screen with the alignment dialog box can be found under the menus **Views/System/Tests/Autosampler**. The alignment procedure must be done with the standard 100-position vial tray installed.

### WARNING

**The alignment procedure has to be performed in the correct order and without skipping parts, to ensure a proper working Autosampler.**

### User Interface

In the Control Module the “Align Tray” function is located in the Control display of the autosampler.

Additional information can be found in the on-line information systems.

The correct procedure for the Control Module are:

- 1 Set alignment to factory default:
  - Go to **Align/Tray** and press button **Default**.
  - Go to **Align/Transport** and press button **Default**.
  - Wait while the Autosampler performs a reset and go back to **Align/Transport**.
- 2 Put capped vials into positions #15 and #95 of the 100-vial tray.
- 3 Move the gripper arm to position of vial #15. Use the **Enter** key to hit **Goto Vial**.
- 4 Use the **Arm down** key(F2) to move the fingers as close as possible to the top of the vial, without the gripper fingers touching the vial.

### 3 Troubleshooting and Test Functions

- 5 Use the Up and Down arrow keys for Theta correction (rotational movement).
- 6 Use the Left and Right arrow keys for X-position correction (horizontal movement).
- 7 Open the gripper (F4) and move it further down for about 5 mm in such a way that vial cap and rubber of gripper fingers have the same height.
- 8 Visually re evaluate if the vial is in the center of the gripper fingers and correct X- and Theta position accordingly.
- 9 Press the **Enter** key to hit **Next Vial**; enter vial #95 and press **Goto Vial**.
- 10 Repeat steps 4 to 8 to align the gripper at position #95.
- 11 Press button Average (F8) to balance the alignment.
- 12 Press button Done (F6) to store the alignment permanently in non-volatile memory and to reset the module.
- 13 To check the result go back to the alignment dialog box, move to vial position #15 and #95 to see if the alignment is acceptable.

#### NOTE

To leave the alignment screen without changes use the **Esc** key.

---

#### NOTE

The result can be a compromise e.g. if the X position at #15 and #95 are off to the same side, then it is OK. However, if at both positions the correction still should be in one direction or, if the failure in one position is larger than the other, you must restart the alignment procedure with step 3. The same goes for the Theta correction.

---

## Step Commands

Each movement of the sampling sequence can be done under manual control. This is useful during troubleshooting where close observation of each of the sampling steps is required to confirm a specific failure mode or verify successful completion of a repair.

Each injector step command actually consists of a series of individual commands which move the autosampler components to predefined positions enabling the specific step to be done.

In the ChemStation the step commands can be selected from the “Test Selection Box” in the Diagnosis display. In the Control Module the step commands can be accessed from the pull-down menu in the autosampler “Test”.

**Table 14** Injector Step Commands

Step	Action	Comments
Bypass	Switches injection valve to the bypass position.	
Plunger Home	Moves the plunger to the home position.	
Needle Up	Lifts the needle arm to the upper position.	Command also switches the valve to bypass if it is not already in that position.
Vial to Seat	Moves the selected vial to the seat position.	Command also lifts the needle to the upper position.
Needle into Vial	Lowers the needle into the vial.	Command also positions the vial at the seat, and lifts the needle to the upper position.

**Table 14** Injector Step Commands (continued)

Step	Action	Comments
Draw	Metering device draws the defined injection volume.	Command also positions the vial at the seat, lifts the needle, and lowers the needle into vial. Command can be done more than once (maximum draw volume of 100µl cannot be exceeded). Use "Plunger Home" to reset the metering device.
Needle Up	Lifts the needle out of the vial.	Command also switches the valve to bypass if it is not already in that position.
Vial to Tray	Returns the selected vial to the tray position.	Command also lifts the needle to the upper position.
Needle into Seat	Lowers the needle arm into the seat.	Command also returns the vial to the tray position.
Mainpass	Switches the injection valve to the mainpass position.	
Needle Up/Mainpass	Lifts the needle arm to the upper position and Switches the injection valve to the mainpass position.	Command available from Control Module only.

## Troubleshooting

If the autosampler is unable to perform a specific step due to a hardware failure, an error message is generated. You can use the injector steps to do the injection sequence, while observing how the instrument responds. Table 15 summarizes the injector steps, and lists the associated error messages and probable causes of step failures.

**Table 15** Step Failures

Step Function	Probable Failure Modes
Bypass	Valve already in bypass. Valve not connected. Defective injection valve.
Plunger Home	Defective or dirty sensor on the sampling-unit flex board. Defective metering-drive motor.
Needle Up	Needle already in the upper position. Defective or dirty sensor on the sampling-unit flex board. Sticking needle-arm assembly. Defective needle-drive motor.
Vial to Seat	No vial in selected position. Vial already in seat position. Defective transport assembly motors. Sticking transport assembly. Defective gripper assembly. Gripper not aligned (see <a href="#">page 89</a> ).
Draw	Sum of all draw volumes exceeds 100µl. Defective metering-drive motor.
Needle Up	Needle already in the upper position. Needle already in the upper position. Defective or dirty sensor on the sampling-unit flex board. Sticking needle-arm assembly. Defective needle-drive motor.

### 3 Troubleshooting and Test Functions

**Table 15** Step Failures (continued)

<b>Step Function</b>	<b>Probable Failure Modes</b>
Vial to Tray	Defective transport assembly motors. Sticking transport assembly. Defective gripper assembly. Gripper not aligned (see <a href="#">page 89</a> ).
Needle Down	Needle already in the lower position. Defective or dirty sensor on the sampling-unit flex board. Sticking needle-arm assembly. Defective needle-drive motor.
Mainpass	Valve already in mainpass. Valve not connected. Defective injection valve.
Needle Up/Mainpass	Blockage in the sample loop or needle (no solvent flow). Needle already in the upper position. Defective or dirty sensor on the sampling-unit flex board. Sticking needle-arm assembly. Defective needle-drive motor. Valve already in mainpass. Valve not connected. Defective injection valve.

## Troubleshooting Guide for the Sample Transport Assembly

This troubleshooting guide is meant to help you diagnose and repair autosampler problems.

In general, autosampler problems can be divided into three categories.

- 1** Intermittent lock-ups with or without vial in the gripper fingers with error messages
  - motor overtemp (0 or 1 or 2 or 3)
  - movement failed (0 or 1 or 2 or 3)
  - missing vial

Many times the sampler is being used very heavily.

- 2** Jittery (shaky) movement in X and/or theta axes and/or when the needle goes through the gripper arm into the vial with error messages
  - motor overtemp (0 or 2)
  - movement failed (0 or 2)
- 3** Poor alignment, seen during vial pickup and vial replacement and/or when the needle hits the gripper arm with error messages
  - motor overtemp (0 or 2 or 3)
  - movement failed (0 or 2 or 3)
  - missing vial

**NOTE**

Motor 0=X; 1=Z; 2=Theta; 3=Gripper.

## Intermittent lock-ups with or without vial in the gripper fingers

With error messages

- motor overtemp (0 or 1 or 2 or 3)
- movement failed (0 or 1 or 2 or 3)
- missing vial

### NOTE

When a motor over temperature message has occurred, the sampler must be turned off for about 10 minutes to allow the motor to cool down.

- 1 Check the firmware and update to the latest revision if necessary.

Since firmware revision A.03.61 (resident A03.60) most “movement failed”, “motor over temp”, “initialization failed (X-axis)” errors are solved.

- 2 Check the vials and the caps.

For reliable operation, vials used with the 1100 Autosampler must not have tapered shoulders or caps that are wider than the body of the vial. For more details see the service note G1313-017.

- 3 Very heavy usage - use a macro.

A pre-sequence macro, **QMBUVHW\_PDF** will automatically reset the sampler at the start of a sequence (ChemStation).

- 4 Check if the “INJECT” line is used in the “Injector Program”.

Remove this line from the program. In this mode the system does not need this command to do the injection. A firmware revision (>3.81) will address this problem. For more details see the service note G1313-018.

- 5 Reset the sampler alignment to default value.

Reset tray alignment, and transport alignment is possible with the Control Module and the ChemStation. To reset the transport alignment with the ChemStation, enter following command in the command line. Print `sendmodule$(lals, “tray:alig 0.00,0.00”)`



**6** Check the tension of the belts.

For this use the **Torque2.mac** and measure the torque for each axis.

**Table 16**

<b>Typical ranges</b>	Theta (both) 30-50
	X-axis (both) 50-90
	Z-axis (both) 90-130
	Gripper open 30-65
	Gripper closed maximum 30

**NOTE**

If the Gripper open/closed torque is not in the range, proceed with STEP 7. If the theta or X torque is not in the range, proceed with STEP 8 (if you think you can adjust the torque), otherwise proceed with STEP 9.

**7** Exchange the gripper arm assembly (part number G1313-60010).

**8** Adjust the belt tension.

- If the measured torque value is too low, the belt needs to be tightened.
- If the measured torque value is too high, the belt needs to be loosened.

For this, slide the motor (X or theta) on the holder bracket in the appropriate direction and test the tension with the **torque2** macro. Repeat this steps until the values are in the appropriate torque range.

**9** Exchange the sample transport assembly (part number G1313-60009 or G1329-60009).

**10** Exchange the main board (part number G1313-69520 or G1329-69520).

## Jittery (shaky) movement in X and or theta axes and/or when the needle goes through the gripper arm into the via

With Error messages

- motor overtemp (0 or 2)
- movement failed (0 or 2)

#### NOTE

When a motor over temperature message has occurred, the sampler must be turned off for about 10 minutes to allow the motor to cool down.

---

- 1 Check the firmware and update to the latest revision if necessary.

Since firmware revision A.03.61 (resident A03.60) most of following errors “movement failed”, “motor over temp” and “initialization failed (X-axis)” are solved.

- 2 Check the cleanliness of the transport rods (X-axis) and clean them.

If the rod is dirty or sticky, clean it with Isopropanol and wipe it with a lint free cloth. The rod can be lubricated with the following synthetic oil: part number 6040-0854.

#### NOTE

DO NOT use other lubricant as mentioned above.

---

- 3 Lubricate the X-gear.

Friction can result in the belt slipping on the gear so that the position of the belt teeth towards the gear changes.

To avoid this, apply some grease from the sample transport repair kit to the X-motor-gear.

**NOTE**

Do not use other grease as the one in the kit and carefully follow the instruction from the technical note.

**4** Check the tension of the belts.

For this use the **Macro2.mac** and measure the torque for theta and X-axis.

**Table 17**

<b>Typical ranges</b>	Theta (both) 30-50
	X-axis (both) 50-90

- If the theta or X torque is not in the range, proceed with STEP 5 (if you think you can adjust the torque). Otherwise proceed with STEP 7.

**5** Adjust the belts tension.

- If the measured torque value is too low, the belt needs to be tightened.
- If the measured torque value is too high, the belt needs to be loosened.

For this, slide the motor (X or theta) on the holder bracket in the appropriate direction and test the tension with the **Torque2.mac** macro. Repeat this steps until the values are in the appropriate torque range.

**6** Reset the sampler alignments to default value.

Reset tray alignment, and transport alignment is possible with the Control Module and the Chemstation. To reset the transport alignment with the Chemstation enter following command in the command line.

Print sendmodule\$(lals, "tray:alig 0.00,0.00")

**7** Exchange the sample transport assembly (part number G1313-60009 or G1329-60009).

**8** Exchange the main board (part number G1313-69520 or G1329-69520).

## Poor alignment, seen during vial pickup and vial replacement and/or when the needle hits the gripper arm

With Error messages

- motor overtemp (0 or 2 or 3)
- movement failed (0 or 2 or 3)

#### NOTE

When a motor over temperature message has occurred, the sampler must be turned off for about 10 minutes to allow the motor to cool down.

---

- 1 Check the firmware and update to the latest revision if necessary.

Since revision A.03.61 (resident A03.60) most of following “movement failed”, “motor over temp” and “initialization failed (X-axis)” errors are solved.

- 2 Reset the sampler alignment to default value.

Reset tray alignment, and transport alignment is possible with the Control Module and the Chemstation. To reset the transport alignment with the Chemstation enter following command in the command line.

Print sendmodule\$(lals, “tray:alig 0.00,0.00”)

- 3 Lubricate the X-gear.

Friction can result in the belt slipping on the gear so that the position of the belt teeth towards the gear changes. To avoid this, apply some grease from the sample transport repair kit to the X-motor-gear.

#### NOTE

Do not use other grease as the one in the kit and carefully follow the instruction from the technical note.

---

4 Check the tension of the belts.

For this use the **Torque2.mac** and measure the torque for each axis.

**Table 18**

<b>Typical ranges</b>	Theta (both) 30-50
	X-axis (both) 50-90
	Z-axis (both) 90-130
	Gripper open 30-65
	Gripper closed maximum 30

**NOTE**

If the Gripper open/closed torque is not in the range, proceed with STEP 5. If the theta or X torque is not in the range, proceed with STEP 6 (if you think you can adjust the torque), otherwise proceed with STEP 7.

5 Exchange the gripper arm assembly (part number G1313-60010).

The gripper arm exchange procedure is explained in the reference manual G1313-90004, section “*Repairing the Autosampler*”.

6 Adjust the belts tension.

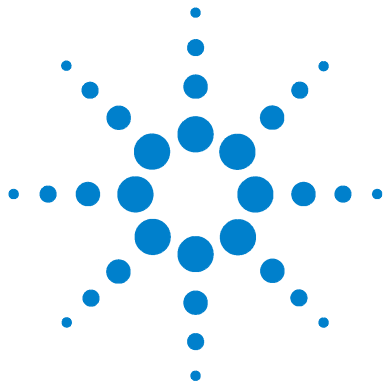
- If the measured torque value is too low, the belt needs to be tightened.
- If the measured torque value is too high, the belt needs to be loosened.

For this, slide the motor on the holder bracket in the appropriate direction and test the tension with the **Torque2.mac** macro. Repeat this steps until the values are in the appropriate torque range.

7 Exchange the sample transport assembly (part number G1313-60009 or G1329-60009).

8 Exchange the main board (part number G1313-69520 or G1329-69520).

### **3 Troubleshooting and Test Functions**



## 4 Repairing the Autosampler

Introduction into Repairing the Autosampler 104

Overview of Main Repair Procedures 107

Simple Repairs 108

Exchanging Internal Parts 130



# Introduction into Repairing the Autosampler

### Simple Repairs

The autosampler is designed for easy repair. The most frequent repairs such as change and needle assembly change can be done from the front of the instrument with the instrument in place in the system stack. These repairs are described in “[Simple Repairs](#)” on page 104.

### Exchanging Internal Parts

Some repairs may require exchange of defective internal parts. Exchange of these parts requires removing the autosampler from the stack, removing the covers, and disassembling the autosampler.

### WARNING

**To prevent personal injury, the power cable must be removed from the instrument before opening the autosampler cover. Do not connect the power cable to the autosampler while the covers are removed.**

---

### Safety Flap, Flex Board

It is strongly recommended that the exchange of the safety flap, and flex board is done by Agilent-trained service personnel.

### Transport Assembly Parts

The adjustment of the motors, and the tension on the drive belts are important for correct operation of the transport assembly (see “[Transport Assembly](#)” on page 136). It is strongly recommended that exchange of drive belts, and the gripper assembly is done by Agilent-trained service personnel. There are no other field-replaceable parts in the transport assembly. If any other component is defective (flex board, spindles, plastic parts) the complete unit must be exchanged.



### Updating the Firmware

The Agilent 1100 Series LC modules are fitted with FLASH EPROMS. These EPROMS enable you to update the instrument firmware from the ChemStation, PCMCIA card, or through the RS232 interface. The firmware update procedure is described in the on-line user information.

### Cleaning the Autosampler

The autosampler covers should be kept clean. Cleaning should be done with a soft cloth slightly dampened with water or a solution of water and a mild detergent. Do not use an excessively damp cloth that liquid can drip into the autosampler.

**WARNING**

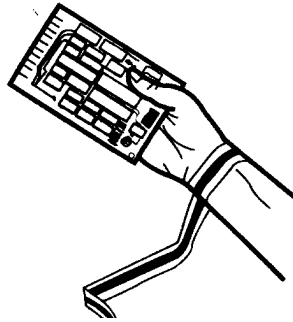
**Do not let liquid drip into the autosampler. It could cause a shock hazard or damage to the autosampler.**

---

### Using the ESD Strap

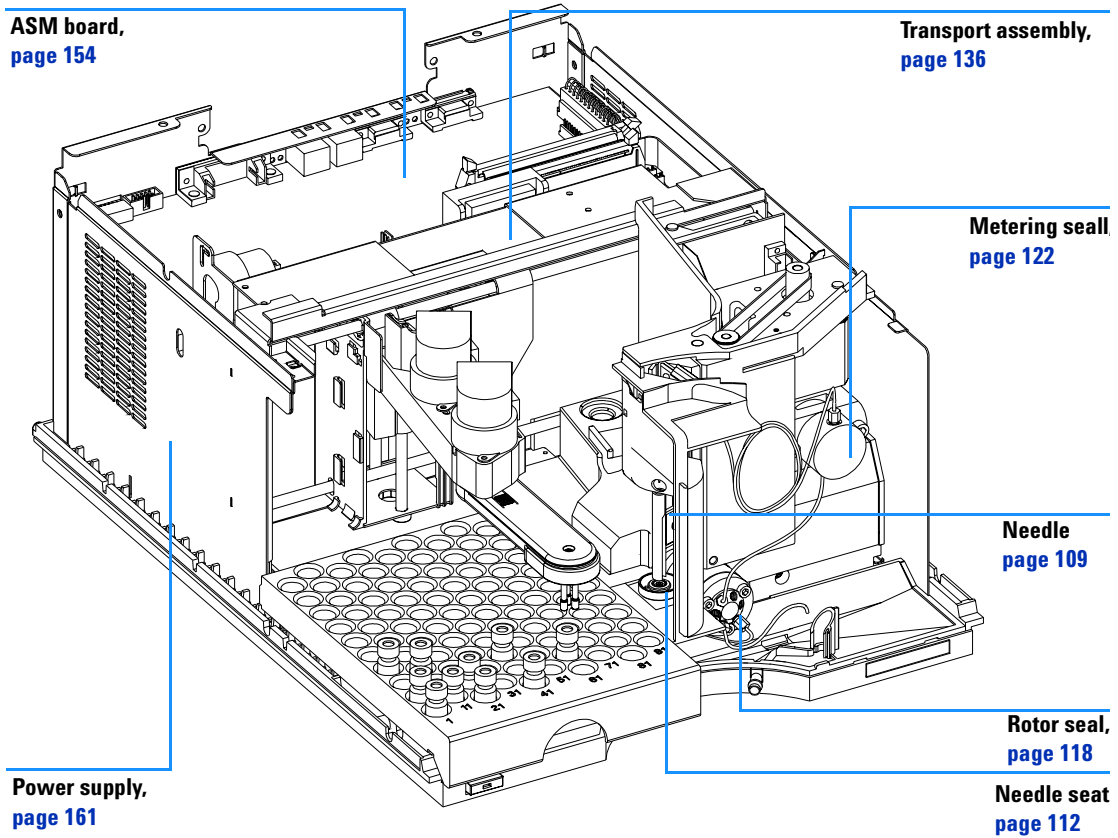
Electronic boards are sensitive to electrostatic discharge (ESD). In order to prevent damage, always use an ESD strap supplied in the accessory kit when handling electronic boards and components.

- 1 Unwrap the first two folds of the band and wrap the exposed adhesive side firmly around your wrist.
- 2 Unroll the rest of the band and peel the liner from the copper foil at the opposite end.
- 3 Attach the copper foil to a convenient and exposed electrical ground.



**Figure 14** Using the ESD Strap

## Overview of Main Repair Procedures



**Figure 15** Main Assemblies

### Simple Repairs

The procedures described in this section can be done with the autosampler in place in the stack. You will do some of these procedures on a more frequent basis.

**Table 19** Simple Repair Procedures

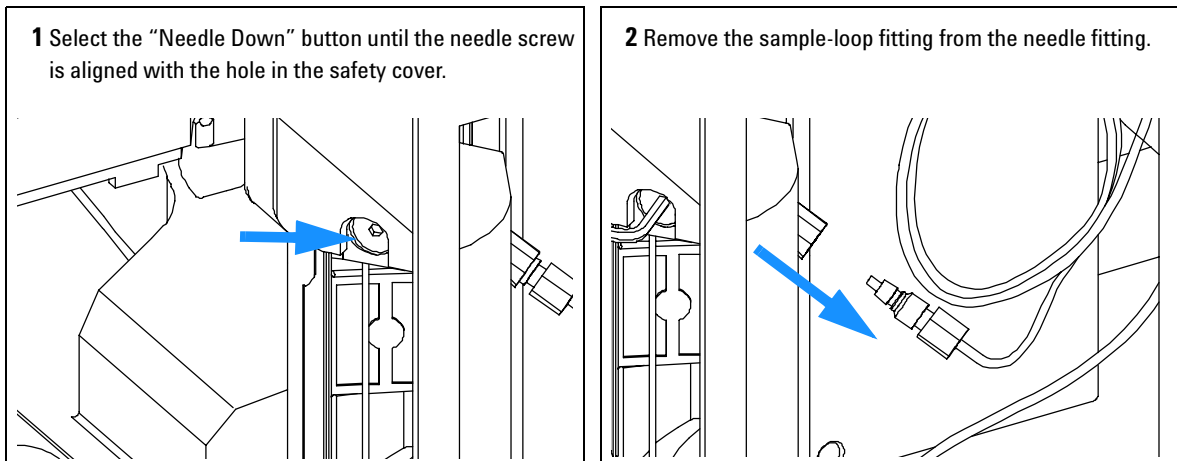
Procedure	Typical Frequency	Time Required	Notes
Exchanging the needle assembly	When needle shows indication of damage or blockage	15 minutes	See <a href="#">"Needle Assembly"</a> on page 109
Exchanging the seat assembly	When the seat shows indication of damage or blockage	10 minutes	See <a href="#">"Needle-Seat Assembly"</a> on page 112
Exchanging the rotor seal	After approximately 30000 to 40000 injections, or when the valve performance shows indication of leakage or wear	30 minutes	See <a href="#">"Rotor Seal"</a> on page 118
Exchanging the metering seal	When autosampler reproducibility indicates seal wear	30 minutes	See <a href="#">"Metering Seal and Plunger"</a> on page 122
Exchanging the gripper arm	When the gripper arm is defective	10 minutes	See <a href="#">"Gripper Arm"</a> on page 126

## Needle Assembly

<b>Frequency</b>	When the needle is visibly damaged When the needle is blocked
<b>Tools required</b>	1/4 inch wrench (supplied in accessory kit) 2.5 mm Hex key (supplied in accessory kit) A pair of pliers
<b>Parts required</b>	Needle assembly (G1313-87201) for G1313-87101 or G1313-87103 needle-seat Needle assembly (G1329-80001) for G1329-87101 or G1329-87103 needle seat Needle assembly (900 µl loop cap) (G1313-87202) for G1313-87101 needle seat Needle assembly (900 µl loop cap) (G2260-87201) for G2260-87101 needle-seat
<b>Preparations for this procedure</b>	Select "Start" in the maintenance function "Change Needle" (see "Change Needle" on page 84). When the needle is positioned approx. 15 mm above the needle seat, remove the front cover.

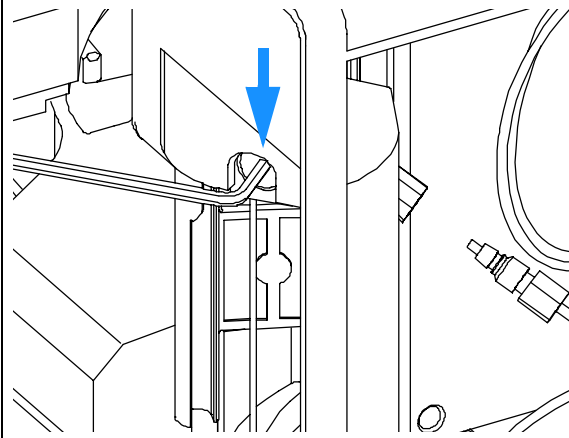
**WARNING**

To avoid personal injury, keep fingers away from the needle area during autosampler operation. Do not bend the safety flap away from its position, or attempt to insert or remove a vial from the gripper when the gripper is positioned below the needle.

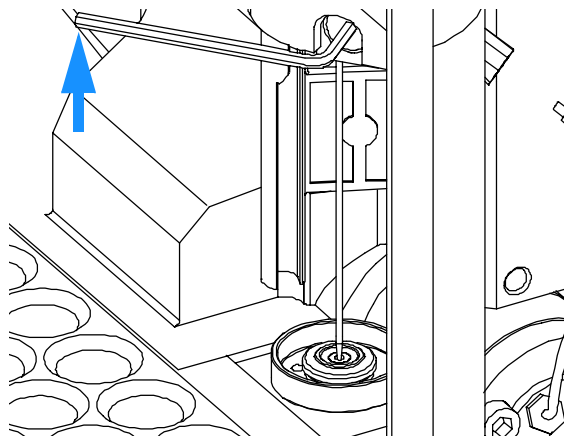


## 4 Repairing the Autosampler

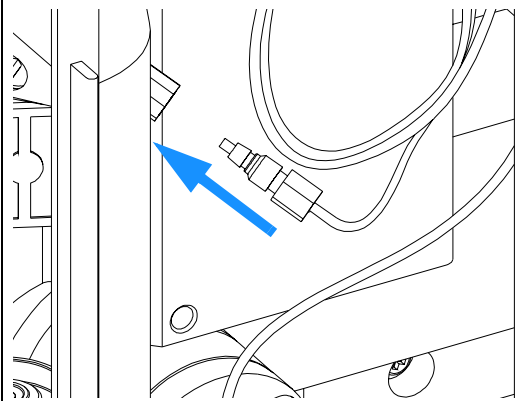
**3** Loosen the fixing screw, and lift out the needle.



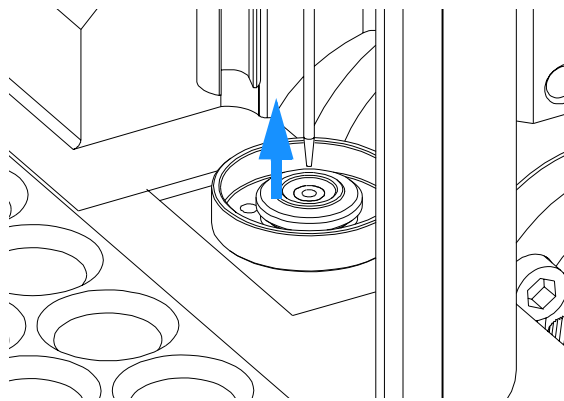
**4** Insert the new needle. Align the needle in the seat, then tighten the screw firmly.



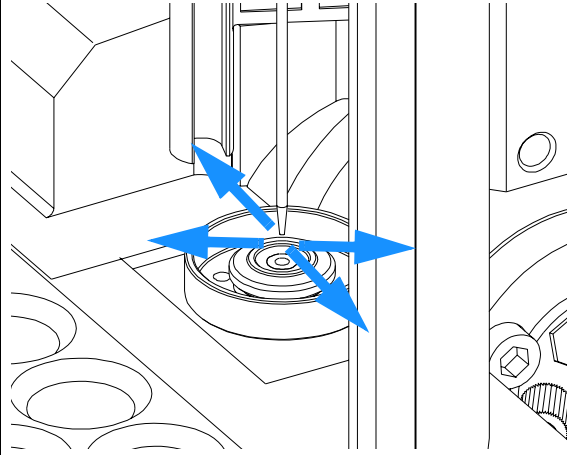
**5** Reconnect the sample-loop fitting to the needle fitting.



**6** Use "Needle Up" to lift the needle to a position approximately 2mm above the seat.



**7** Ensure the needle is aligned with the seat.



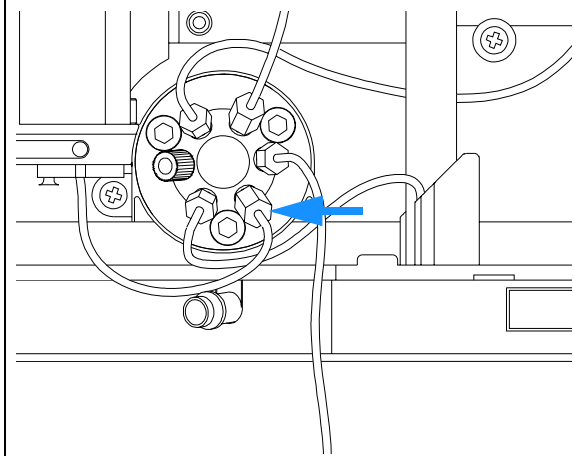
**On completion of this procedure:**

- Install the front cover.
- Select "End" in the maintenance function "Change Needle" (see "Change Needle" on page 84).

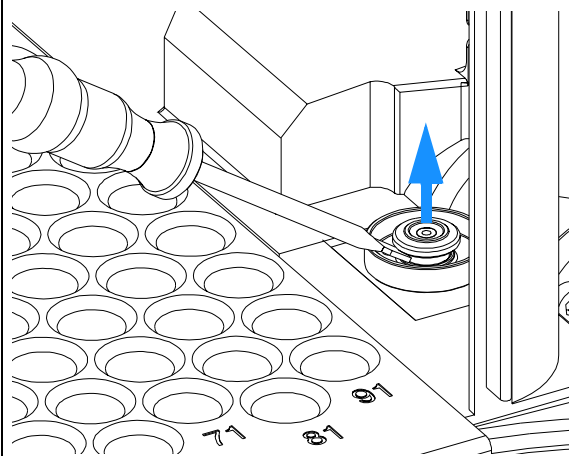
### Needle-Seat Assembly

<b>Frequency</b>	When the seat is visibly damaged When the seat capillary is blocked
<b>Tools required</b>	1/4 inch wrench (supplied in accessory kit). Flat-head screwdriver.
<b>Parts required</b>	Needle-seat assy (0.17 mm i.d 2.3 µl) G1313-87101 for G1313-29A Needle-seat assy (0.12 mm i.d 1.2 µl) G1313-87103 for G1313-29A Needle seat assy (0.10 mm i.d 1.2 µl) G1329-87101 for G1389A Needle seat assy (0.05 mm i.d 0.3 µl) G1329-87103 for G1389A Needle-seat assy (0.50 mm i.d 20 µl) G2260-87101 for G2260A
<b>Preparations for this procedure</b>	Select "Start" in the maintenance function "Change Needle" (see "Change Needle" on page 84). Remove the front cover. Use the "Needle Up" command in the "Change Needle" function to lift the needle an addition 1 cm.

**1** Disconnect the seat-capillary fitting from the injection valve (port 5).

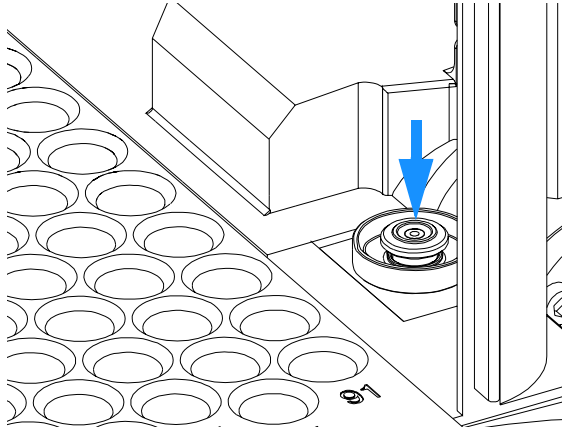


**2** Use a small flat-head screwdriver to ease out the needle seat.

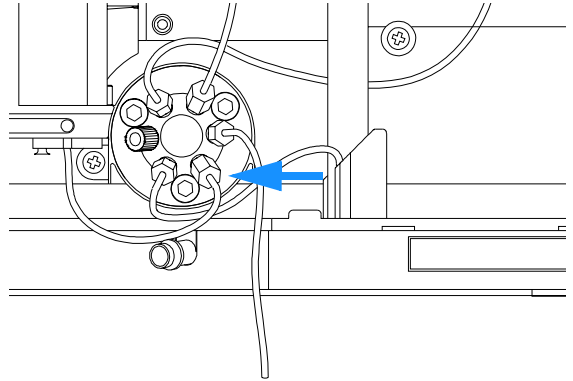




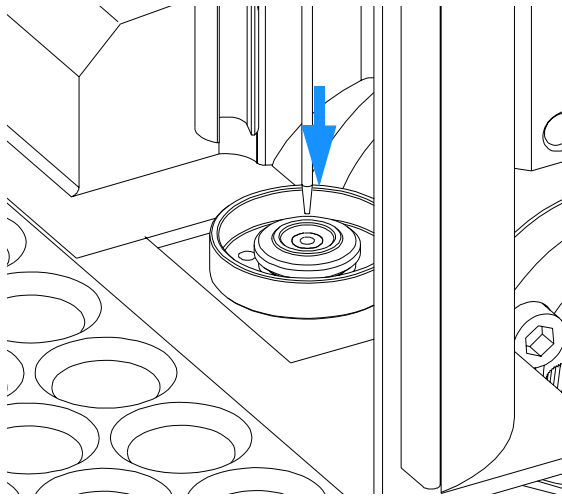
**3** Insert the new needle-seat assembly. Press the seat firmly into position.



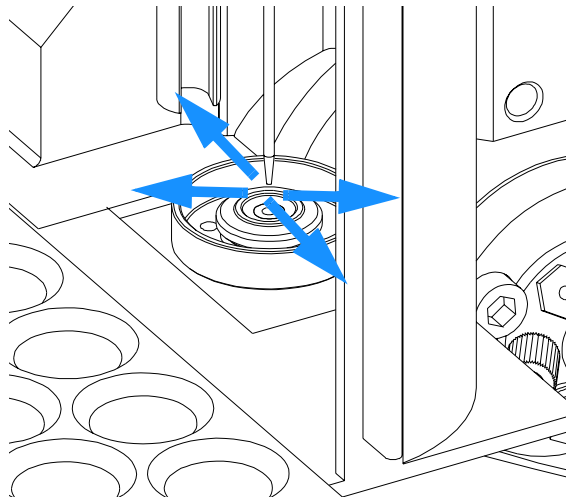
**4** Connect the seat-capillary fitting to port 5 of the injection valve.



**5** Use the "Down" button to position the needle approximately 2 mm above the seat



**6** Ensure the needle is aligned with the seat. If required, bend the needle slightly until the needle is aligned correctly.



## 4 Repairing the Autosampler

**On completion of this procedure:**

- Install the front cover.
- Select “End” in the maintenance function “Change Needle” (see [“Change Needle”](#) on page 84).

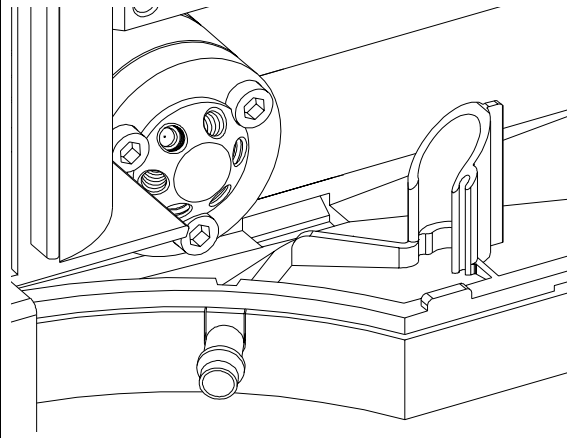
## Stator Face

<b>Frequency</b>	Poor injection-volume reproducibility Leaking injection valve
<b>Tools required</b>	1/4 inch wrench (supplied in accessory kit) Hex key, 9/64 inch (supplied in accessory kit)
<b>Parts required</b>	Stator face 0100-1851 for <i>G1313A</i> and <i>G1329A</i> Stator face 0101-1268 for <i>G2260A</i>
<b>Preparation</b>	Remove the front cover. Remove the leak tubings (if necessary).

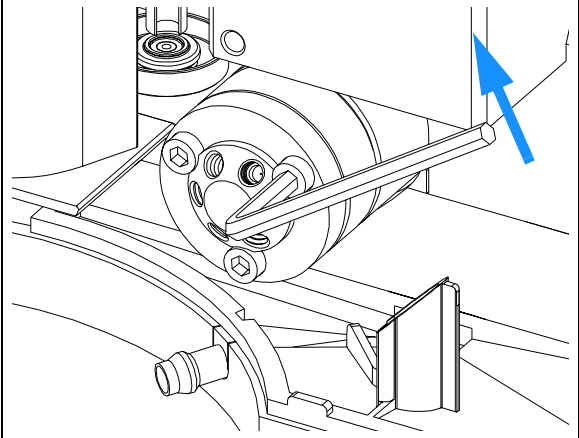
### CAUTION

The stator face is held in place by the stator head. When removing the stator head, ensure the stator face does not fall out of the valve.

**1** Remove all capillary fittings from the injection-valve ports.

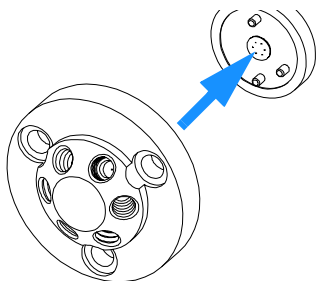


**2** Loosen each fixing bolt two turns at a time. Remove the bolts from the head.

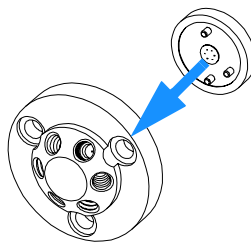


## 4 Repairing the Autosampler

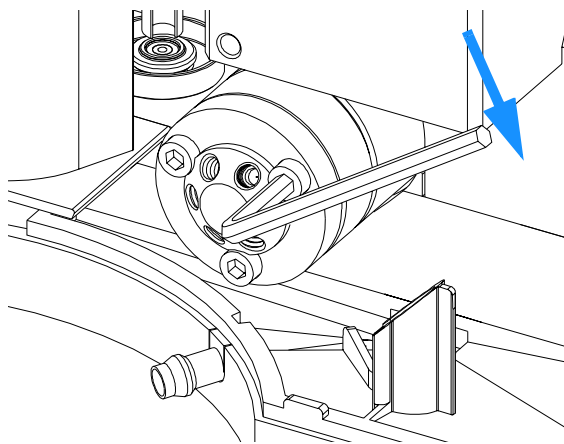
**3** Remove the stator head and stator face.



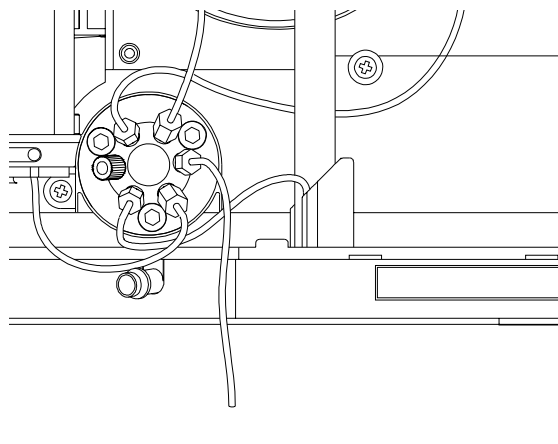
**4** Place the stator face in place on the stator head. Ensure the pins on the stator engage in the holes in the stator head.



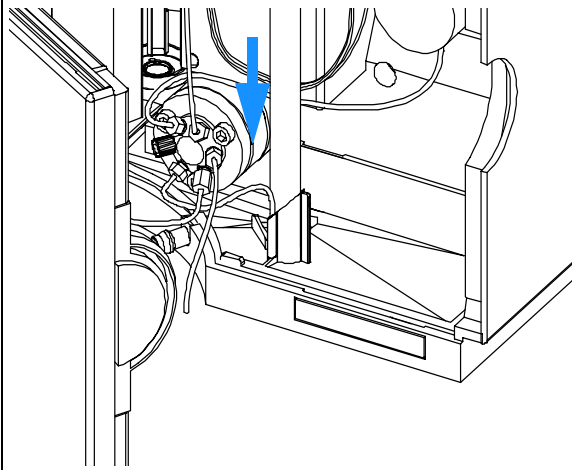
**5** Install stator head and stator face. Tighten the bolts alternately two turns at a time until the stator head is secure.



**6** Reconnect the pump capillaries to the valve ports (see ["Hydraulic Connections"](#) on page 33).



**7** Slide the waste tube into the waste holder in the leak tray.



**On completion of this procedure:**

- Install the front cover.

## 4 Repairing the Autosampler

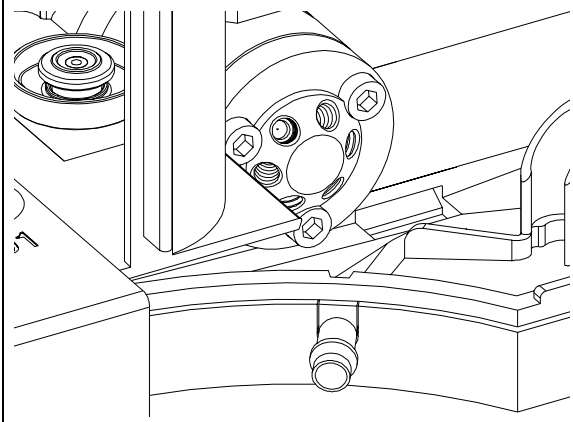
### Rotor Seal

<b>Frequency</b>	Poor injection-volume reproducibility Leaking injection valve
<b>Tools required</b>	1/4 inch wrench (supplied in accessory kit). Hex key, 9/64 inch (supplied in accessory kit).
<b>Parts required</b>	Rotor seal 0100-1853 (Vespel) for G1313A and G1329A Rotor seal 0100-1849 (Tefzel) for G1313A and G1329A Rotor seal 0100-2088 (Vespel) for G1389A Rotor seal 0101-1268 (PEEK) for G2260A
<b>Preparations for this procedure</b>	Remove front cover. Remove the leak tubing (if necessary).

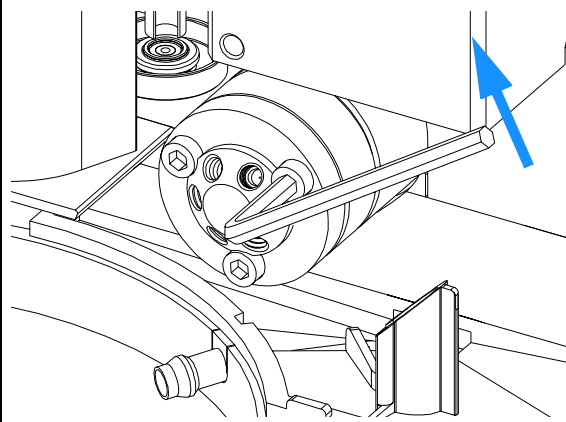
#### CAUTION

The stator face is held in place by the stator head. When removing the stator head, ensure the stator face does not fall out of the valve.

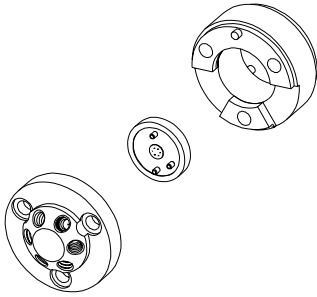
**1** Remove all capillary fittings from the injection-valve ports.



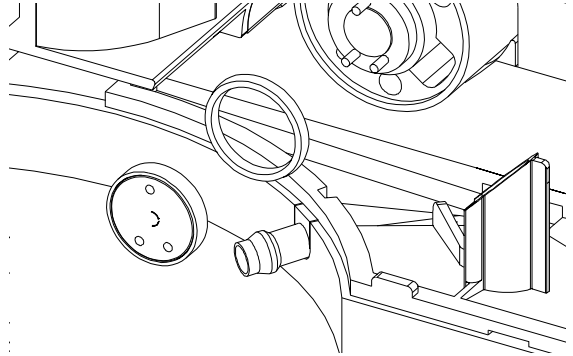
**2** Loosen each fixing bolt two turns at a time. Remove the bolts from the head.



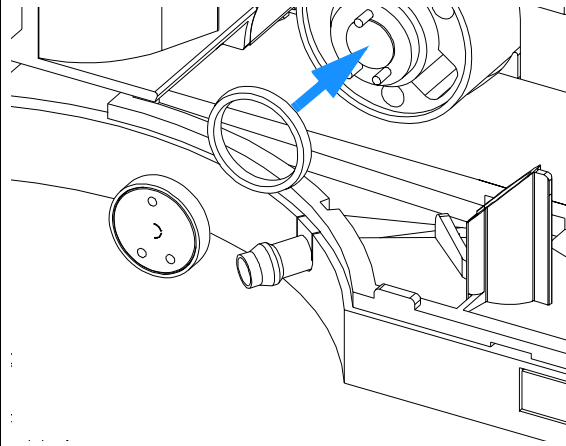
**3** Remove the stator head, stator face and stator ring.



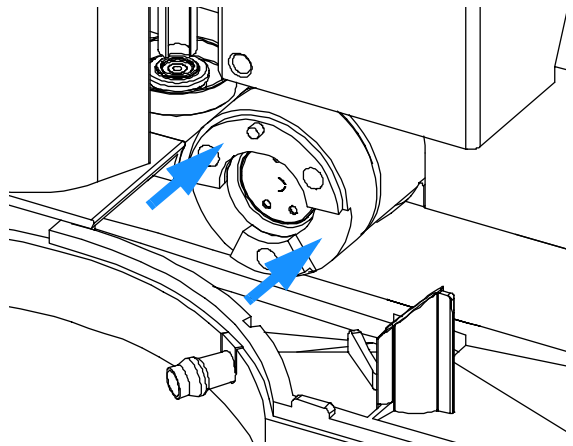
**4** Remove the rotor seal and isolation seal.



**5** Install the new rotor seal and isolation seal. Ensure the metal spring inside the isolation seal faces towards the valve body.

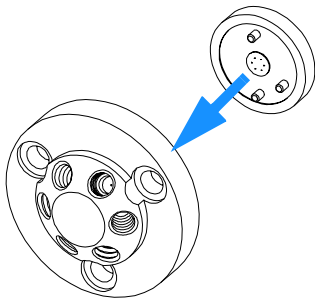


**6** Install the stator ring with the short of the two pins facing towards you at the 12 O'Clock position. Ensure the ring sits flat on the valve body.

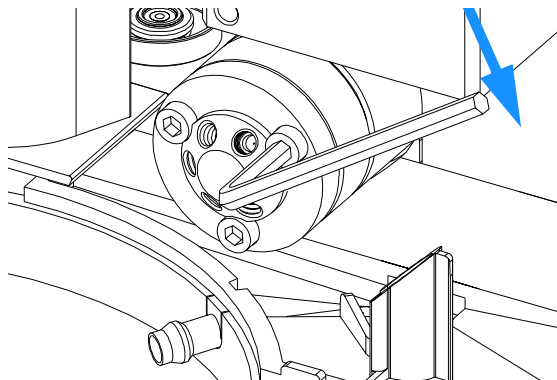


## 4 Repairing the Autosampler

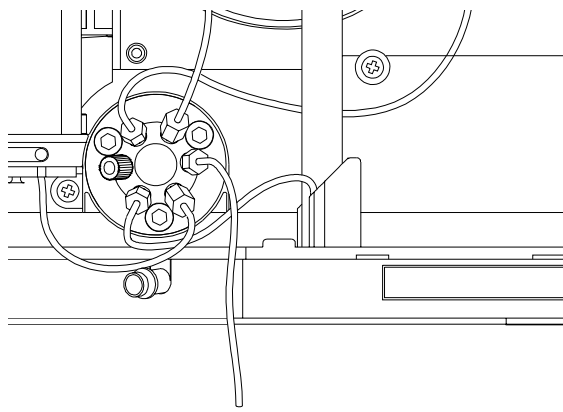
**7** Place the stator face in place on the stator head.



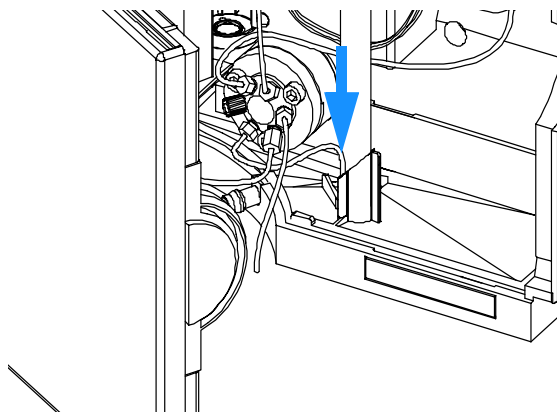
**8** Install stator head and stator face. Tighten the bolts alternately two turns at a time until the stator head is secure.



**9** Reconnect the pump capillaries to the valve ports (see "Hydraulic Connections" on page 33).



**10** Slide the waste tube into the waste holder in the leak tray.





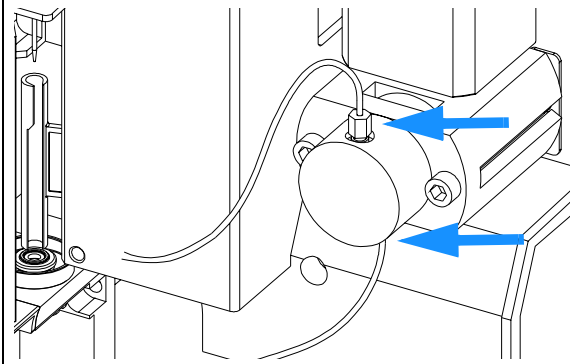
**On completion of this procedure:**

- Install the front cover.

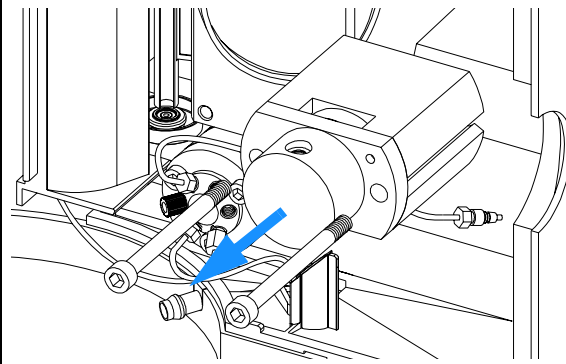
### Metering Seal and Plunger

<b>Frequency</b>	Poor injection-volume reproducibility Leaking metering device
<b>Tools required</b>	1/4 inch wrench (supplied in accessory kit). 4 mm hex key (supplied in accessory kit). 3 mm hex key (supplied in accessory kit).
<b>Parts required</b>	Metering seal 5063-6589 (pack of 2) <i>for 100 µl analytical head</i> Metering seal 5022-2175 (pack of 1) <i>for 40 µl analytical head</i> Metering seal 0905-1294 (pack of 1) <i>for 900 µl analytical head</i>  Metering plunger 5063-6586 <i>for 100 µl analytical head</i> Metering plunger 5064-8293 <i>for 40 µl analytical head</i> Metering plunger 5062-8587 <i>for 900 µl analytical head</i> (only if scratched or contaminated)
<b>Preparations for this Procedure</b>	Select "Start" in the maintenance function "Change piston" (see <a href="#">"Change Piston"</a> on page 86). Remove the front cover.

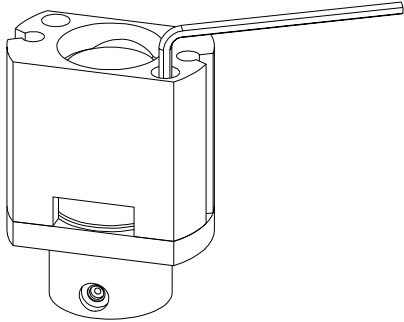
**1** Remove the two capillaries from the metering-head assembly.



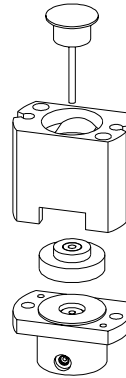
**2** Remove the two fixing bolts, and pull the head assembly away from the sampler. Notice that the closed side of the metering head faces upwards.



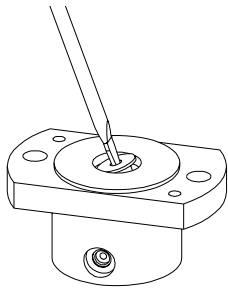
**3** Remove the two fixing bolts from the base of the metering head assembly.



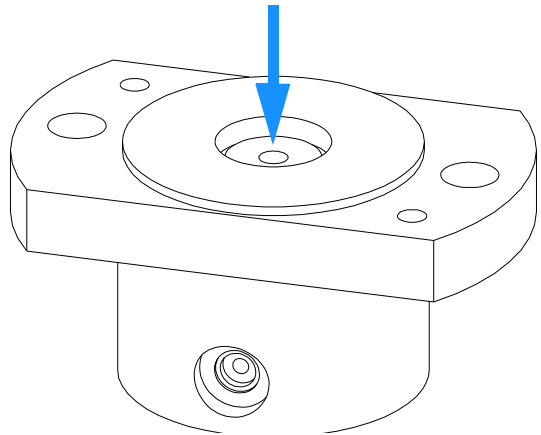
**4** Disassemble the metering head assembly.



**5** Use a small screwdriver to carefully remove the seal. Clean the chamber with lint-free cloth. Ensure all particular matter is removed.

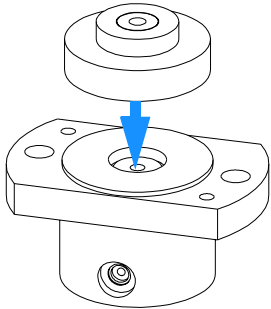


**6** Install the new seal. Press the seal firmly into position.

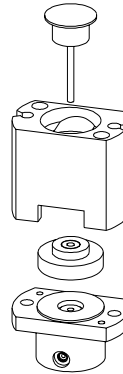


## 4 Repairing the Autosampler

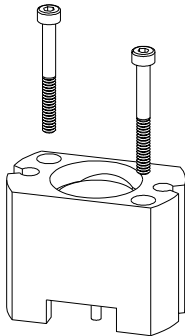
**7** Place the piston guide on top of the seal.



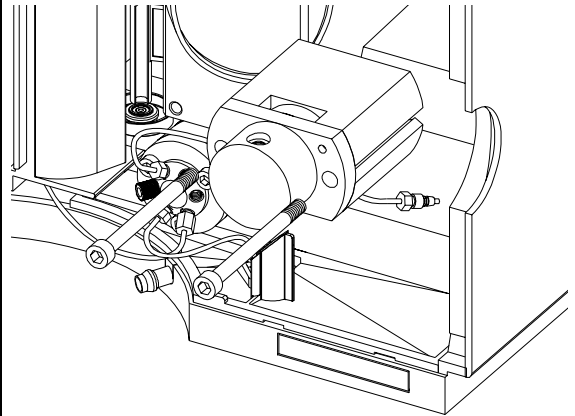
**8** Reassemble the metering head assembly. Carefully insert the plunger into the base. The closed side of the metering head must be on the same side as the lower one of the two capillary drillings.

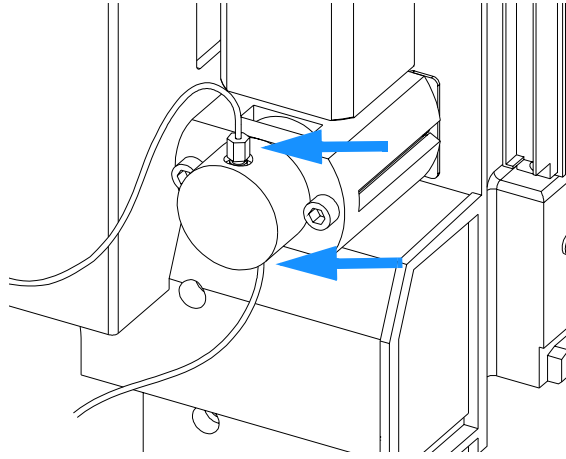


**9** Install the fixing bolts. Tighten the bolts securely.



**10** Install the metering head assembly in the autosampler. Ensure the large hole in the metering head is facing downwards.



**11 Reinstall the capillaries.****On completion of this procedure:**

- Install the front cover.
- Select "End" in the maintenance function "Change piston" (see "Change Piston" on page 86).

## 4 Repairing the Autosampler

### Gripper Arm

**Frequency**

Tools required

Parts required

Preparations for this procedure

Defective gripper arm

Straightened paper clip.

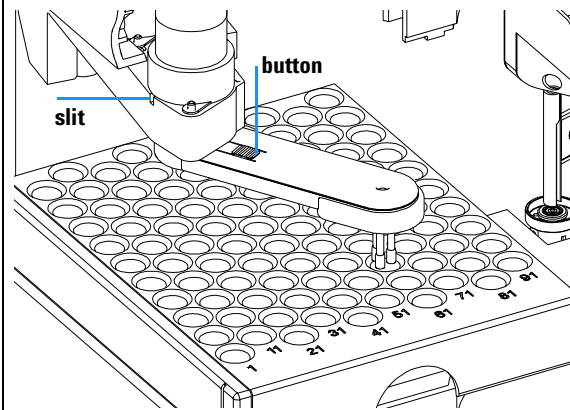
Gripper assembly, G1313-60010.

Select "Start" in the maintenance function "ChangeGripper" (see "Change Gripper (Change Arm)" on page 88).

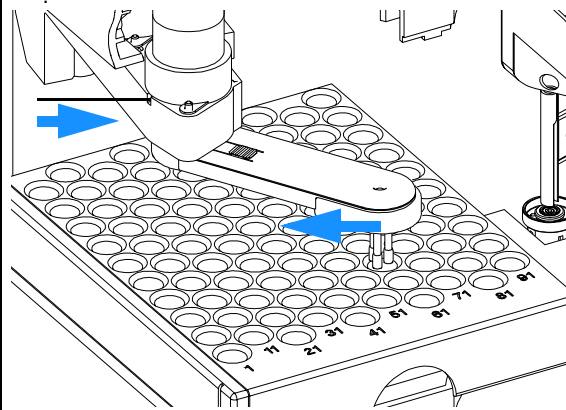
Turn off the power to the autosampler.

Remove the front cover.

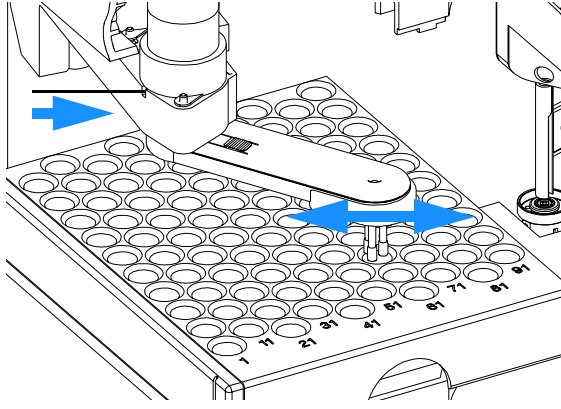
1 Identify the slit below the gripper motor and the gripper arm release button.



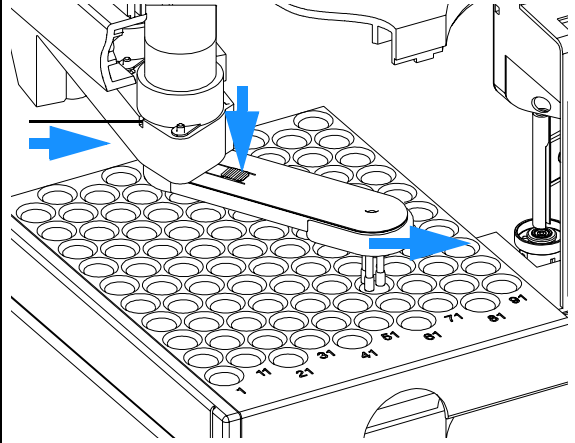
2 Rotate the arm approximately 2.5cm (1 inch) to the left and insert the straightened paper clip into the slit.



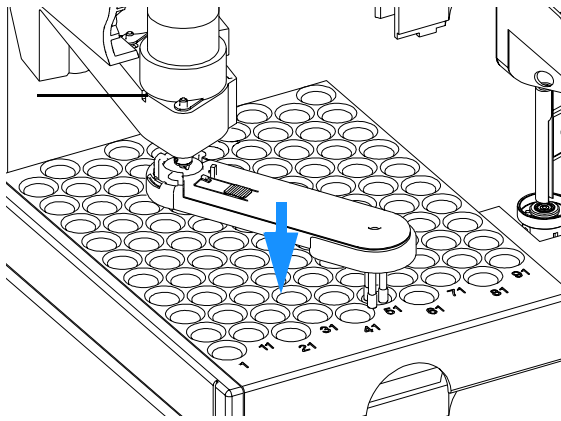
**3** Rotate the gripper arm slowly from left to right and apply a gentle pressure to the paper clip. The clip will engage on an internal catch and the rotation of the arm will be blocked.



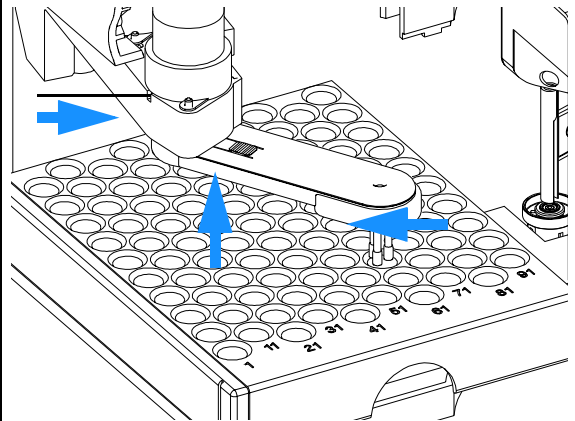
**4** Hold the paper clip in place, press the gripper release button and rotate the gripper arm to the right.



**5** The gripper arm will come off.



**6** Replace the gripper arm by holding the paper clip in place, pushing the gripper arm into the holder and rotating the gripper arm to the left.



## 4 Repairing the Autosampler

**On completion of this procedure:**

- Install the front cover.
- Turn the power to the autosampler on.



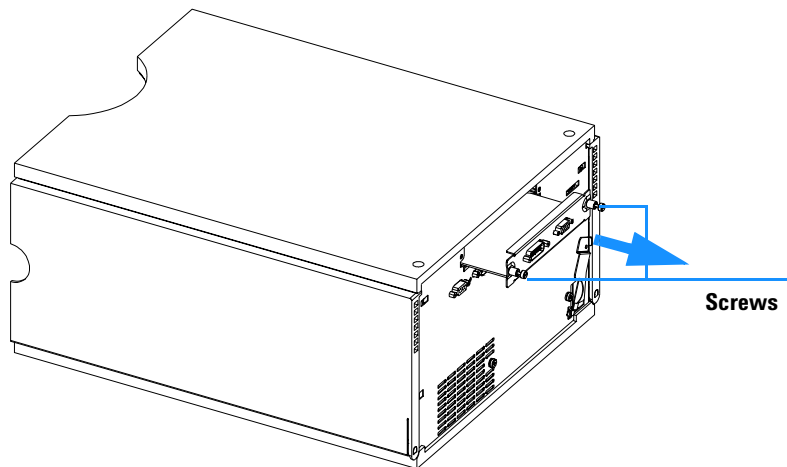
## Interface Board

<b>Frequency</b>	At installation or when defective.
<b>Tools required</b>	Flat-head screwdriver.
<b>Parts required</b>	Interface board, see " <a href="#">Optional Interface Boards</a> " on page 239.

### CAUTION

The interface board is sensitive to electrostatic discharge. Always use the ESD strap when handling electronic boards.

- 1 Switch off the autosampler at the main power switch.
- 2 Disconnect cables from the interface board connectors.
- 3 Loosen the screws. Slide out the interface board from the autosampler.
- 4 Install the interface board. Secure the screws.
- 5 Reconnect the cables to the board connectors



**Figure 16** Exchanging the Interface Board

### Exchanging Internal Parts

#### WARNING

The following procedures require opening the main cover of the autosampler. Always ensure the autosampler is disconnected from the line power when the main cover is removed. The security lever at the power input socket prevents the autosampler cover from being taken off when line power is still connected.

---

#### WARNING

The power supply still uses some power, even if the power switch on the front panel is turned off. To disconnect the autosampler from line power, unplug the power cord.

---

#### WARNING

When opening capillary or tube fittings solvents may leak out. Please observe appropriate safety procedures (for example, goggles, safety gloves and protective clothing) as described in the material handling and safety data sheet supplied by the solvent vendor, especially when toxic or hazardous solvents are used.

---

#### NOTE

The electronics of the autosampler will not allow operation when the top cover and the top foam are removed. A safety light switch on the main board will inhibit the operation of the autosampler. Always operate the autosampler with the top foam and top covers in place.

---

#### CAUTION

Internal components may be sensitive to electrostatic discharge (ESD). Always use an ESD strap when handling internal components (see [“Using the ESD Strap”](#) on page 106).

---

The procedures in this section describe how to exchange defective internal parts. You must remove the autosampler from the stack in order to open the main cover.

## Assembling the Main Cover

<b>Tools required</b>	None
<b>Parts required</b>	G1313-68703 Cover kit for <i>G1313A</i> G1329-68703 Cover kit for <i>G1329A - G1389A - G2260A</i> G1329-68706 Cabinet upgrade kit for <i>G1313A - G1329A</i> 5042-1381 Name plate

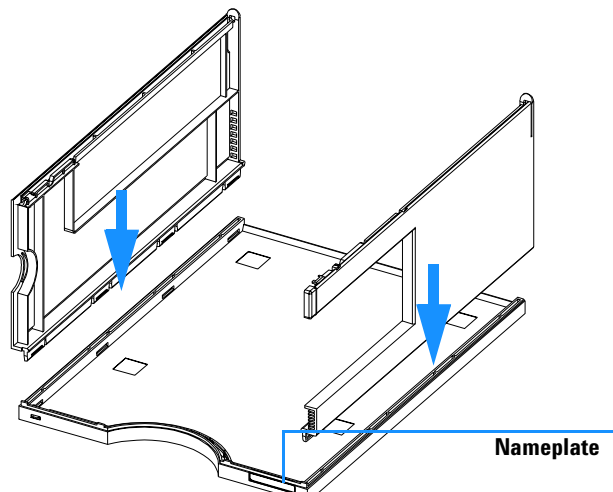
### NOTE

The plastics kit contains all parts, but it is not assembled.

### CAUTION

Observe the assembly instructions carefully. The main cover cannot be disassembled once assembled incorrectly.

- 1 Insert the “Agilent Technologies 1100 Series” nameplate into the recess in the top cover
- 2 Place the top cover on the bench.
- 3 Press the side panels into the slots in the top cover



**Figure 17** Assembling the Main Cover

## 4 Repairing the Autosampler

### Top Cover and Foam

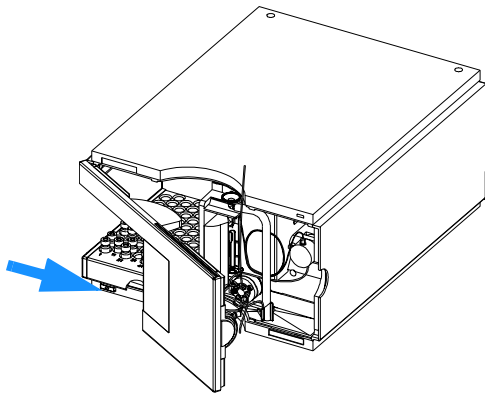
**Frequency**  
**Tools required**  
**Parts required**

When accessing internal parts.  
If interface board installed: Flat-head screwdriver.  
Foam kit G1313-68702

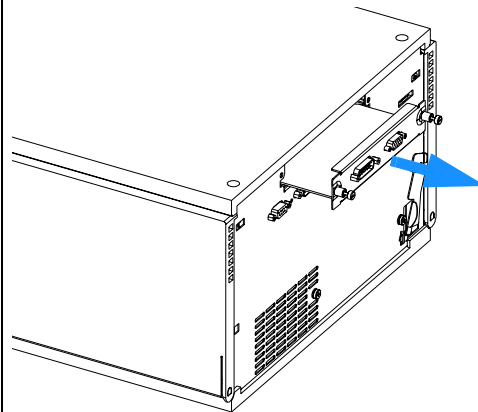
#### CAUTION

This procedure requires removal of the MIO-interface board. The board is sensitive to electrostatic discharge. Always use the ESD strap when handling electronic boards.

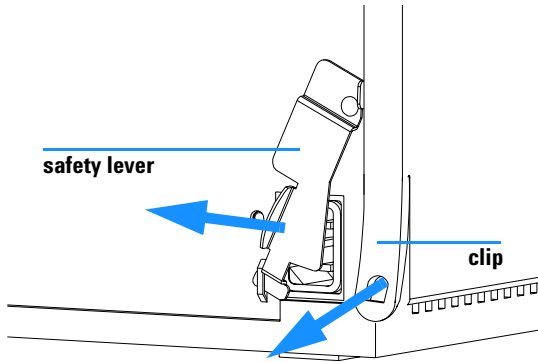
- 1 Switch off the autosampler at the main power switch. Remove the power cable.



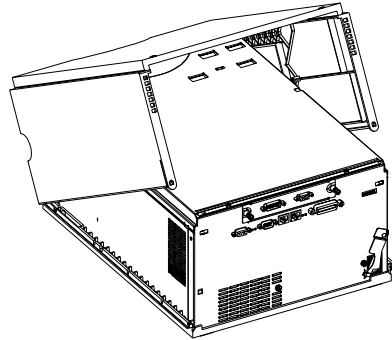
- 2 If installed, remove the ECB board.



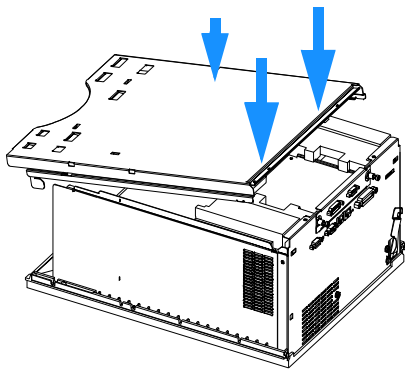
**3** Move the safety lever to the left. Lift the clips on the top cover.



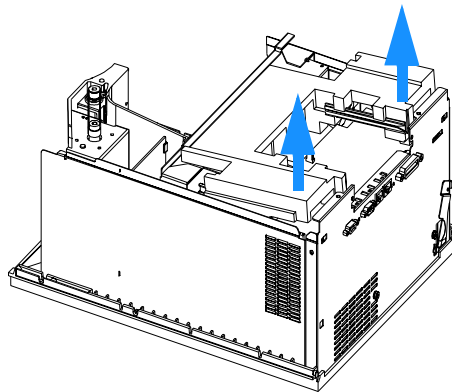
**4** Lift the cover away.



**5** Unscrew the three screws on the top plate. Remove the top plate.



**6** Carefully remove the top foam.



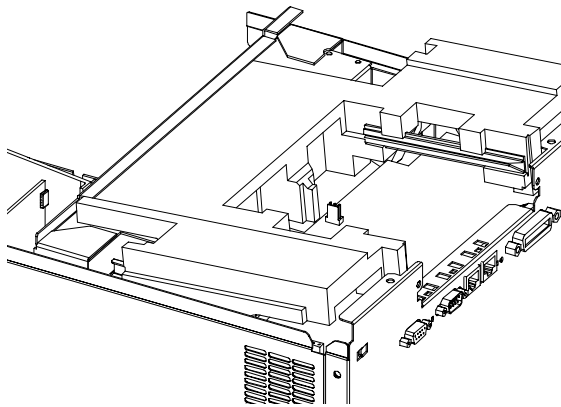
## 4 Repairing the Autosampler

### Installing the Top Cover and Foam

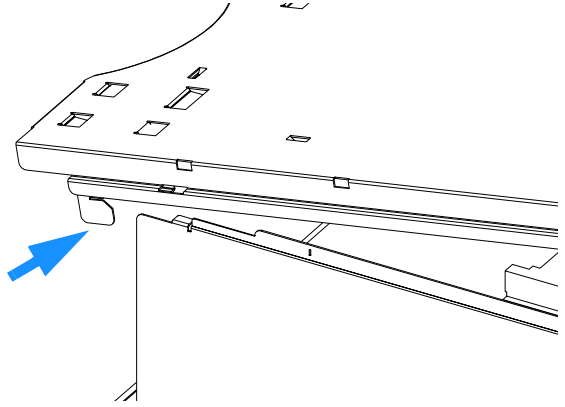
**Frequency**  
**Tools required**  
**Parts required**

When accessing internal parts.  
If interface board installed: Flat-head screwdriver.  
None.

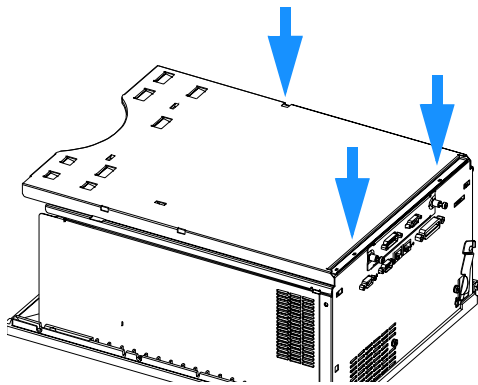
1 Install the top foam. Press the foam firmly into place.



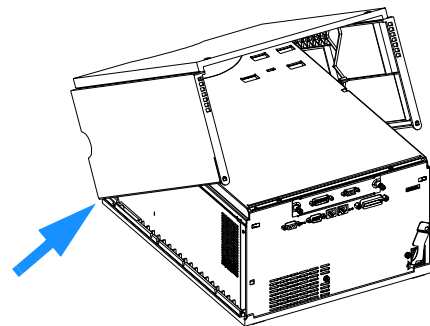
2 Engage the slot on the top plate onto the side plate.



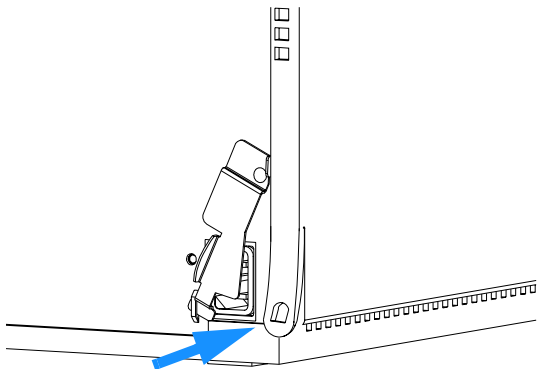
3 Fix the top plate in place with the three screws.



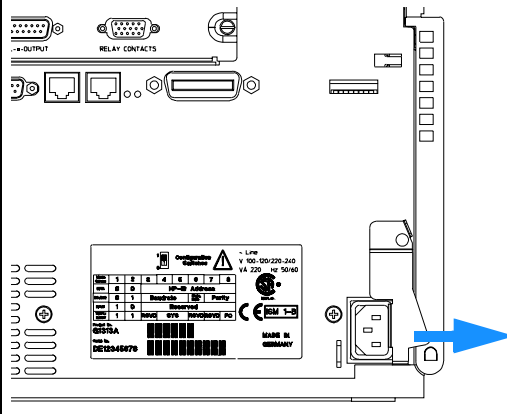
4 Engage the top cover into the bottom cover.



**5** Lower the cover into place. Ensure the clips close firmly.



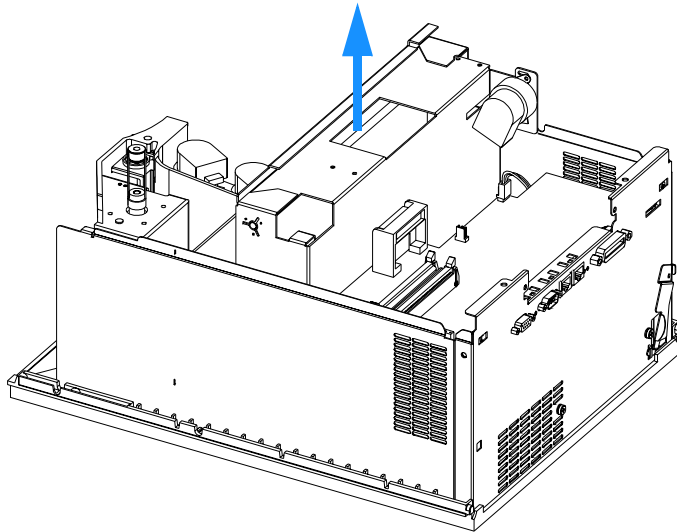
**6** Slide the power lock to the right, and install the power cable.



### Transport Assembly

<b>Frequency</b>	Sticking or jammed transport assembly. Defective flex board or sensors.
<b>Tools required</b>	If interface board installed: Flat-head screwdriver.
<b>Parts required</b>	Transport assembly G1313-60009 for G1313A Transport assembly G1329-60009 for G1329A - 1389A - G2260A

- 1 Remove the top cover, top plate, and foam (see “[Top Cover and Foam](#)” on page 132).
- 2 Lift out the transport assembly. This may require a flat head screwdriver to separate the transport assembly from the sampling unit

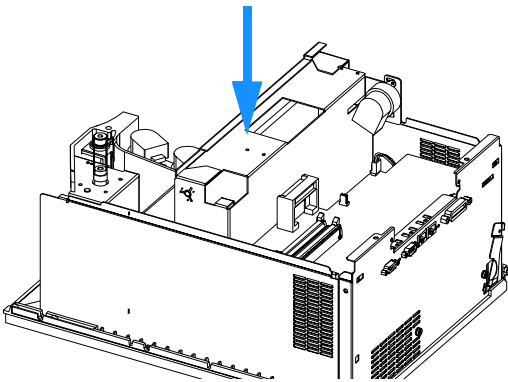


**Figure 18** Removing the Transport Assembly

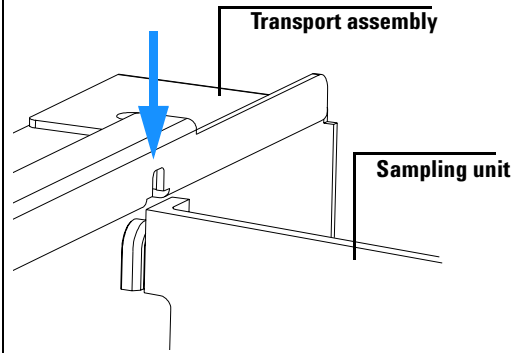


## Installing the Transport Assembly

1 Slide the transport assembly into the autosampler.



2 Ensure the slot on the top of the transport assembly engages with the stud on the sampling unit.



### On completion of this procedure:

- Ensure the transport assembly is seated firmly.
- Install the top cover and foam ([page 132](#)).
- Verify the transport assembly alignment ([page 100](#)).

## 4 Repairing the Autosampler

### Sampling Unit

**Frequency**  
**Tools required**

When accessing internal parts, or when defective.  
1/4 inch wrench (supplied in accessory kit).  
Flat-head screwdriver.

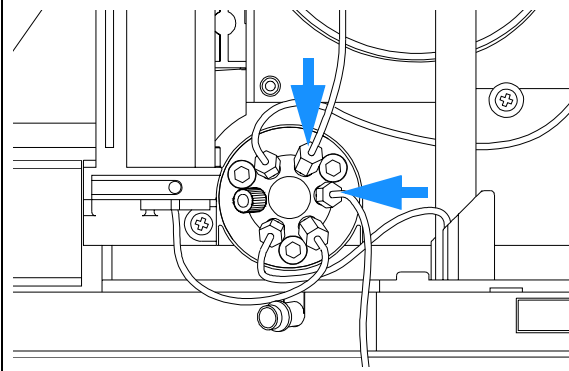
**Parts required**

Sampling unit G1313-60008 for G1313A  
Sampling unit G1329-60008 for G1329A  
Sampling unit G1329-60018 for G1389A  
Sampling unit G2260-60008 for G2260A  
The sampling units come without injection valve and analytical head assembly (see "Sampling Unit Assembly" on page 171).

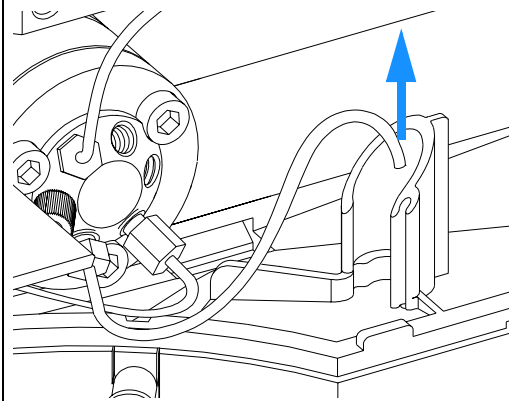
**Preparations for this procedure**

Remove the front cover.  
Remove the vial tray.  
Remove the top cover (page 132).  
Remove the transport assembly (page 136).

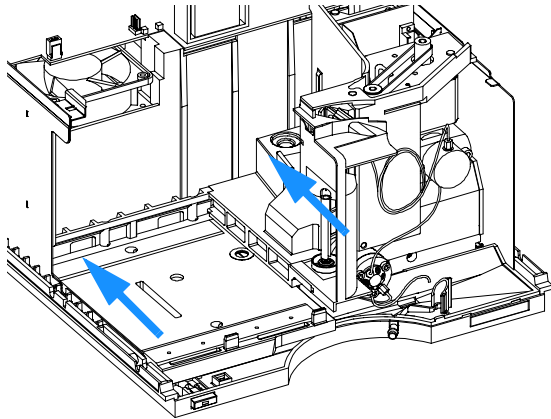
**1** Remove the pump and column thermostat capillaries (ports 1 and 6) from the injection valve.



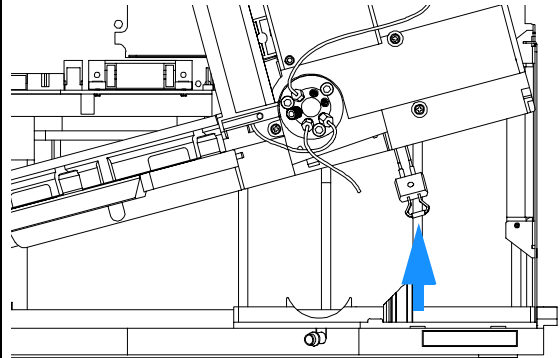
**2** Pull out the waste tube from the holder in the leak tray.



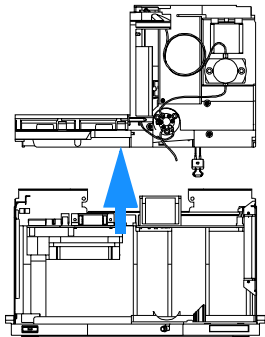
**3** Slide the sampling unit and tray base back to disengage the sampling-unit connector.



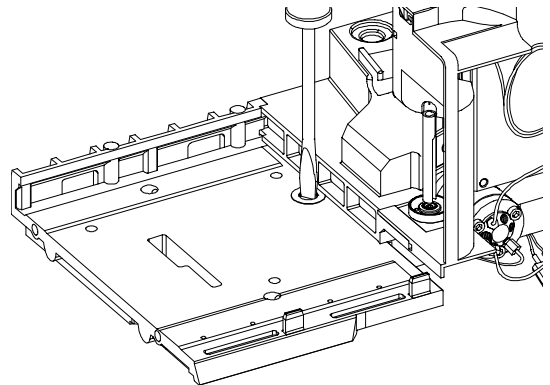
**4** Lift the sampling unit and tray base approximately 10 cm. Slide the leak sensor out of the leak plane.



**5** Lift the sampling unit and tray base out of the autosampler.

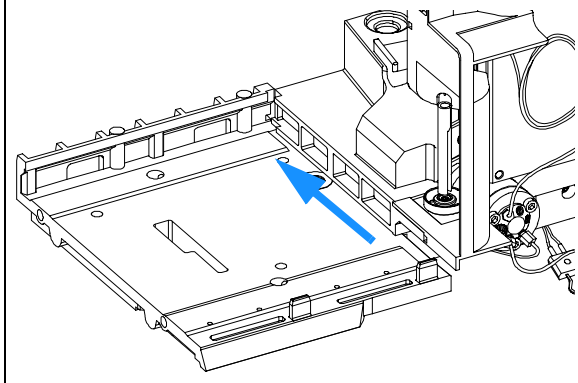


**6** Turn the tray-base locking screw ¼-turn anti-clockwise.



## 4 Repairing the Autosampler

7 Slide the tray base back to disengage the tray base from the sampling unit.



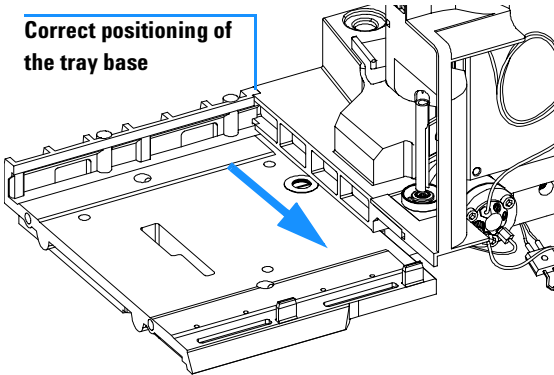
## Installing the Sampling Unit

**NOTE**

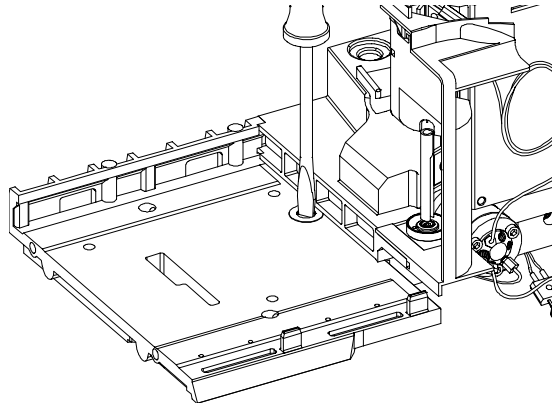
The replacement sampling unit is supplied without injection valve and metering head assembly. If you are exchanging the complete sampling unit, remove the injection valve and metering head from the defective sampling unit. Install the valve and metering head in the new sampling unit. See "Injection-Valve Assembly" on page 144 and "Gripper Arm" on page 126.

- 1** Mount the tray base onto the sampling unit. Ensure the tray base is positioned flush against the sampling unit.

**Correct positioning of the tray base**

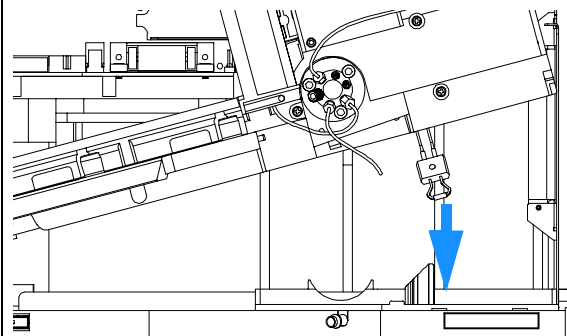


- 2** Tighten the locking screw ¼-turn clockwise.

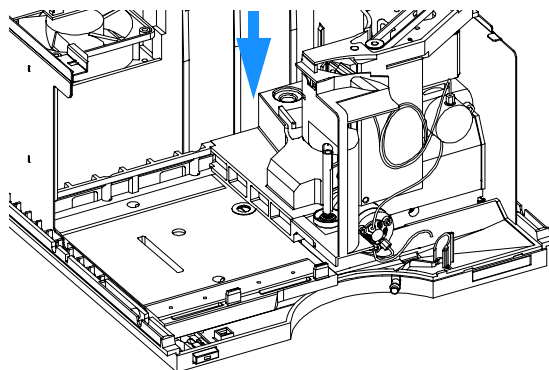


## 4 Repairing the Autosampler

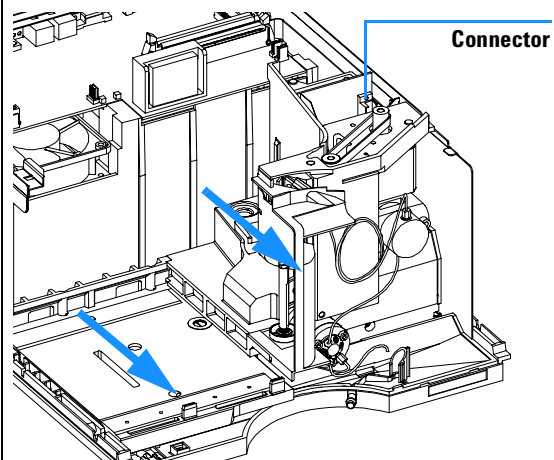
**3** While holding the sampling unit and tray base, slide the leak sensor into the holder in the leak plane.



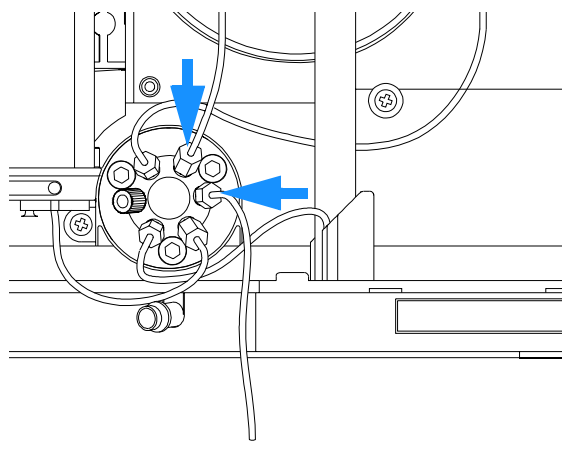
**4** Place the sampling unit and tray base into the autosampler.



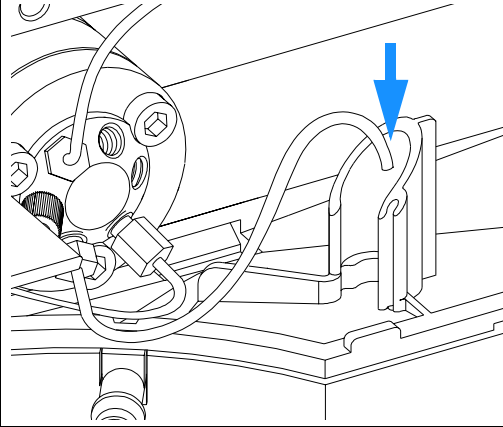
**5** Slide the sampling unit and tray base forwards. Ensure the sampling unit connector is seated correctly.



**6** Install the pump and column thermostat capillaries (ports 1 and 6) in the injection valve.



7 Install the waste tube in the holder in the leak tray.



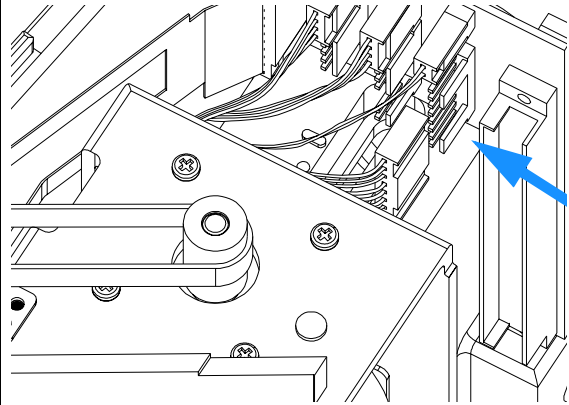
**On completion of this procedure:**

- Install the transport assembly ([page 136](#)).
- Install the top cover ([page 132](#)).
- Install the vial tray.
- Verify the transport assembly alignment ([page 100](#)).

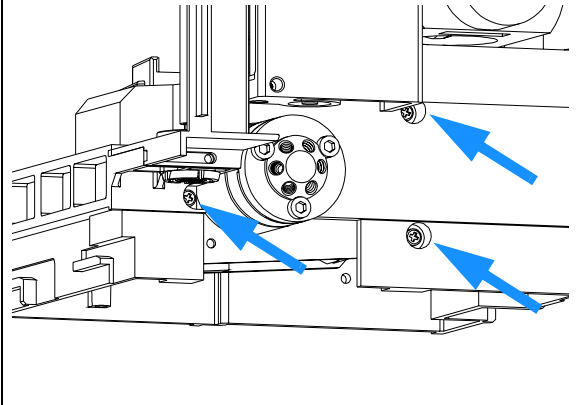
## Injection-Valve Assembly

<b>Frequency</b>	When defective
<b>Tools required</b>	Pozidrive No. 1 screwdriver 1/4 inch wrench
<b>Parts required</b>	Injection valve 0101-0921 for G1313A G1329A Injection valve 0101-1050 for G1389A Injection valve 0101-1267 for G2260A
<b>Preparations for this procedure</b>	Remove all capillaries from the injection valve (page 33). Remove the top cover (page 132). Remove the transport assembly (page 136). Remove the sampling unit (page 138).

1 Disconnect the valve-cable connector from the SUD board (labelled "Valve Assy").

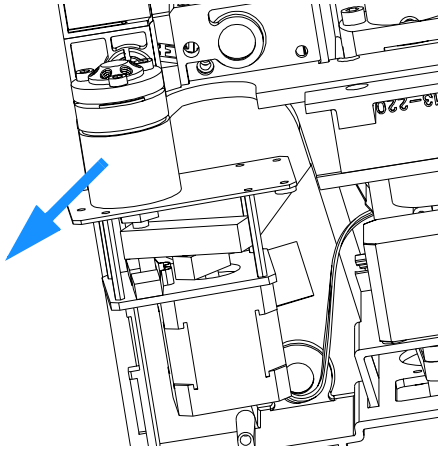


2 Remove the three fixing screws.

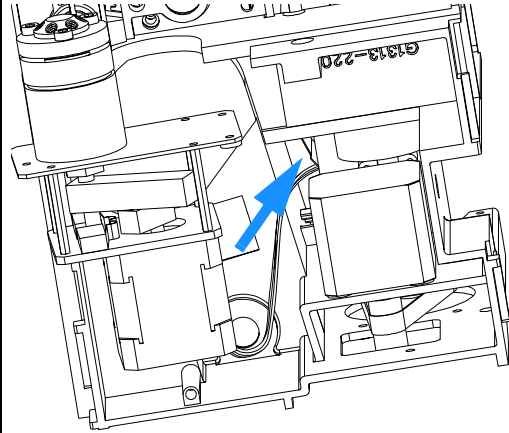




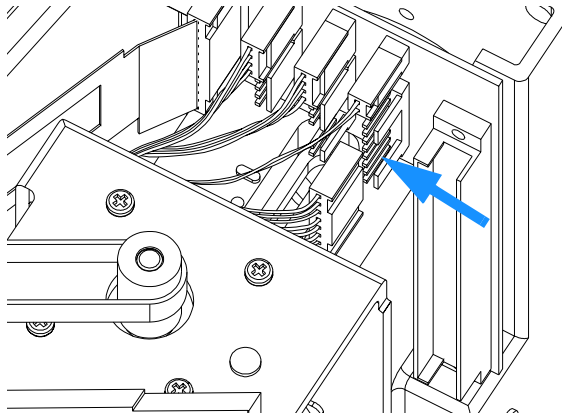
**3** Remove the injection-valve assembly.



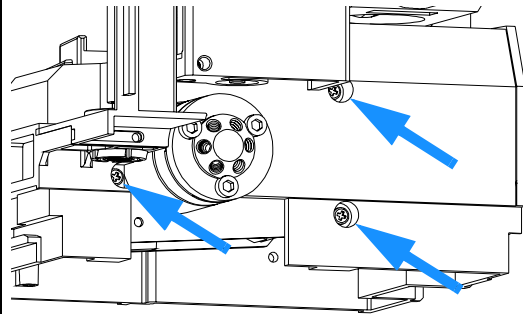
**4** Feed the cable of the new valve through to the SUD board).



**5** Connect the valve cable to the connector (labelled "Valve Assy").



**6** Fix the valve assembly in place securely with the three screws.



## 4 Repairing the Autosampler

**On completion of this procedure:**

- Install the sampling unit ([page 138](#)).
- Install the transport assembly ([page 136](#)).
- Install the top cover ([page 132](#)).
- Replace the injection-valve capillaries ([page 33](#)).
- Verify the transport assembly alignment ([page 100](#)).

## Metering-Drive Motor and Belt

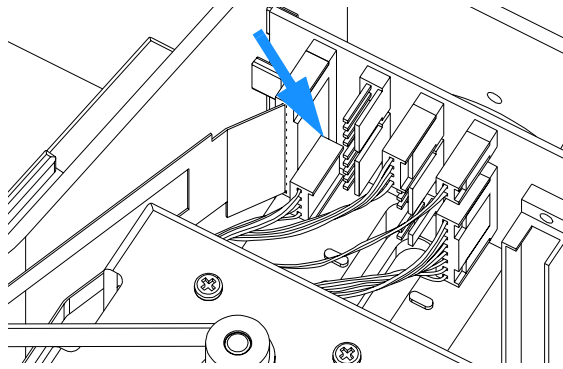
**Frequency**  
**Tools required**  
**Parts required**

When belt or motor defective  
 Pozidrive No. 1 screwdriver  
 Metering-drive motor 5062-8590  
 Belt 1500-0697

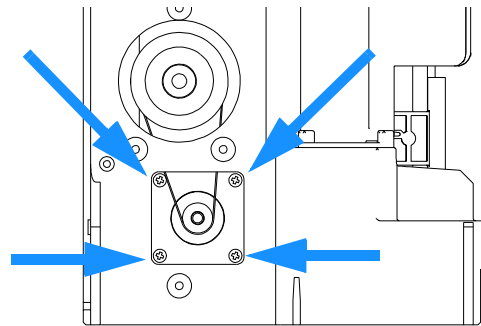
**Preparations for this procedure**

Remove the top cover ([page 132](#)).  
 Remove the transport assembly ([page 136](#)).  
 Remove the sampling unit ([page 138](#)).

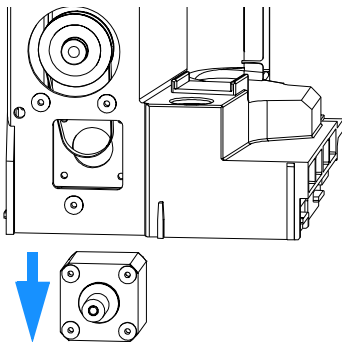
**1** Disconnect the motor connector from the SUD board (labelled "Metering M").



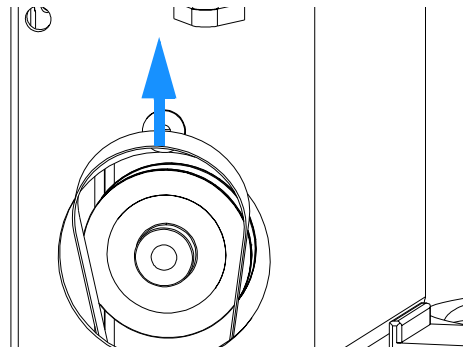
**2** Remove the four fixing screws.



**3** Remove the motor.

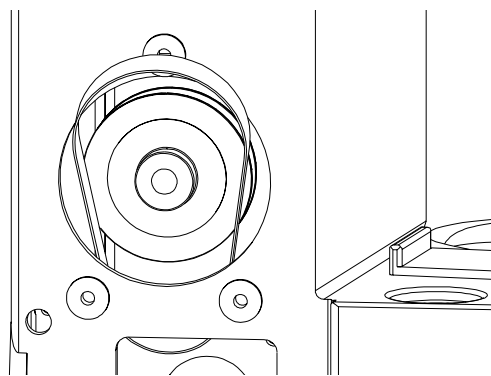


**4** Remove the belt.

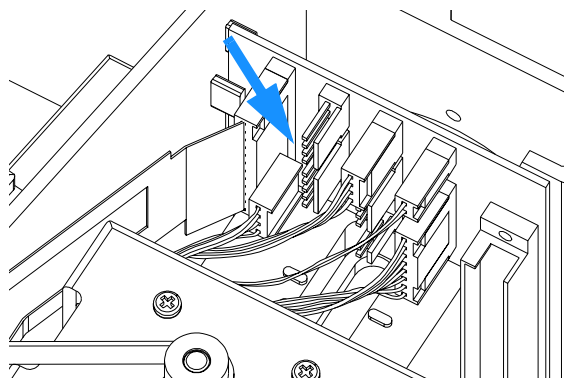


## 4 Repairing the Autosampler

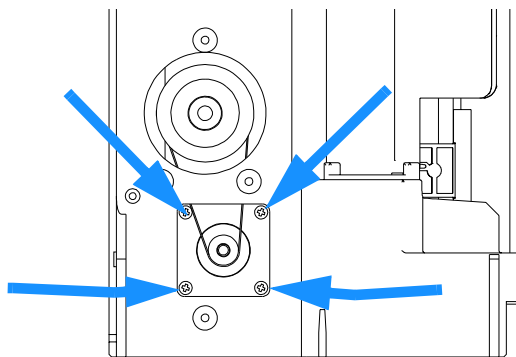
**5** Place the belt over the shaft.



**6** Feed the motor cable through to the SUD board. Connect the cable to (labelled "Metering M").



**7** Install the motor with the four fixing screws. Ensure the belt is seated correctly over the gear and motor shaft.



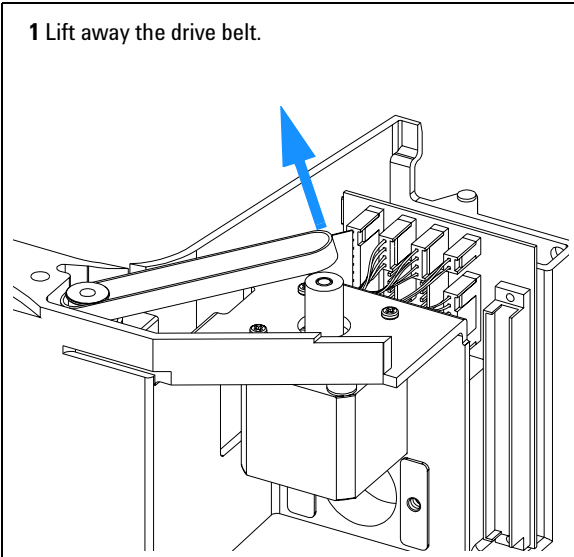
**On completion of this procedure:**

- Install the sampling unit ([page 138](#)).
- Install the transport assembly ([page 136](#)).
- Install the top cover ([page 132](#)).
- Verify the transport assembly alignment ([page 100](#)).

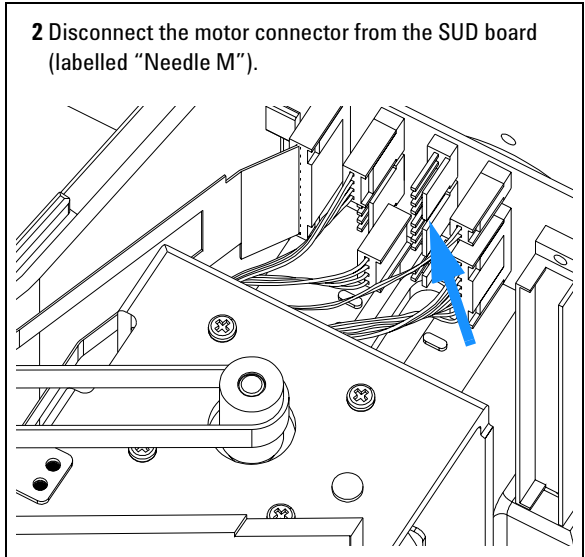
## Needle-Drive Motor and Belt

<b>Frequency</b>	When defective
<b>Tools required</b>	Pozidrive No. 1 screwdriver
<b>Parts required</b>	Needle-drive motor 5062-8590 Belt 1500-0697
<b>Preparations for this procedure</b>	Remove the top cover (page 132).

**1** Lift away the drive belt.

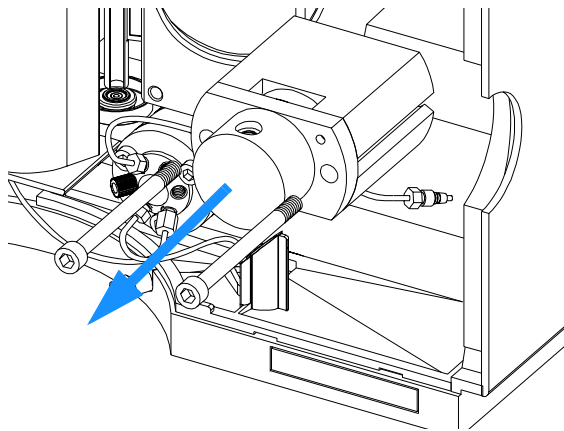


**2** Disconnect the motor connector from the SUD board (labelled "Needle M").

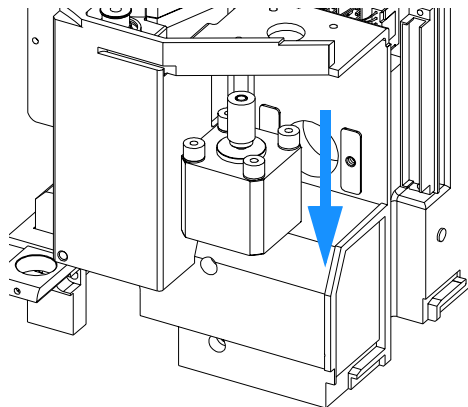


## 4 Repairing the Autosampler

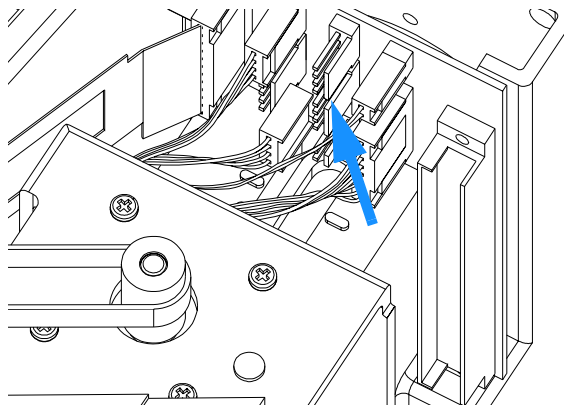
**3** Remove the metering head assembly (see "Gripper Arm" on page 126).



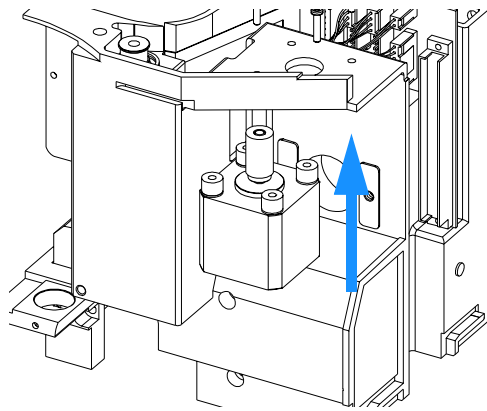
**4** Remove the four fixing screws, and remove the motor.



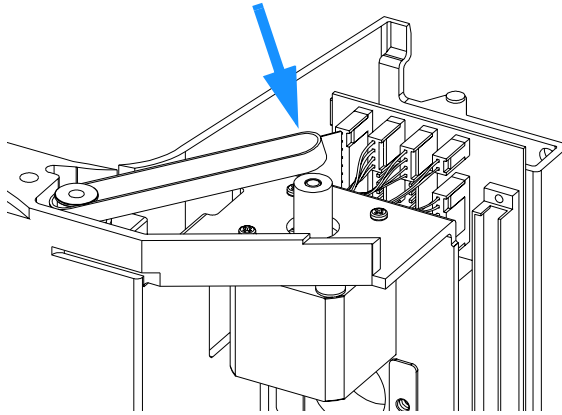
**5** Feed the motor cable through to the SUD board. Connect the cable to the connector, labelled "Needle M".



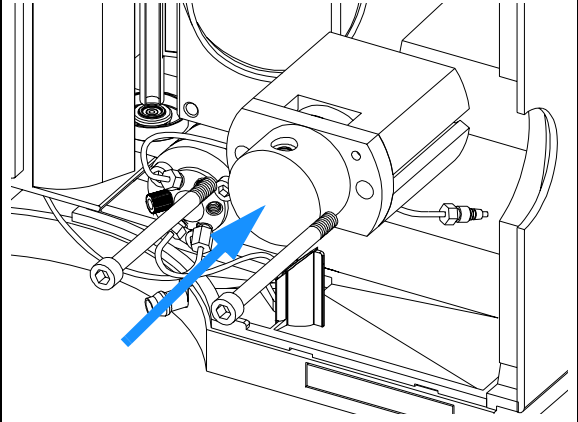
**6** Secure the motor in place with the four fixing screws.



**7** Install the belt.



**8** Install the metering-head assembly (see "Gripper Arm" on page 126).



**On completion of this procedure:**

- Install the top cover ([page 132](#)).
- Verify the transport assembly alignment ([page 100](#)).

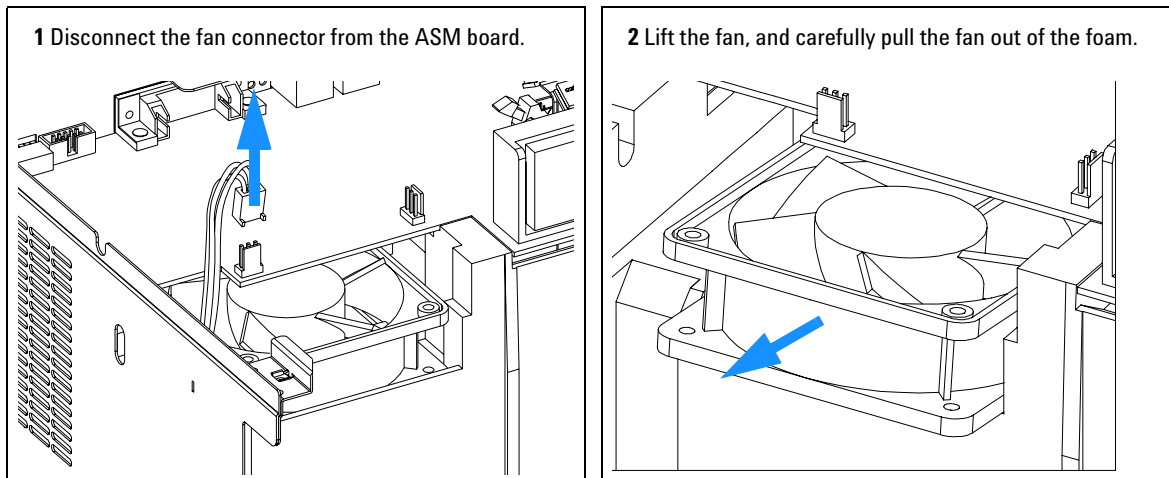
## 4 Repairing the Autosampler

### Fan

<b>Frequency</b>	When defective.
<b>Tools required</b>	None.
<b>Parts required</b>	Fan 3160-1017
<b>Preparations for this procedure</b>	Remove the top cover and foam (page 132). Remove the transport assembly (page 136).

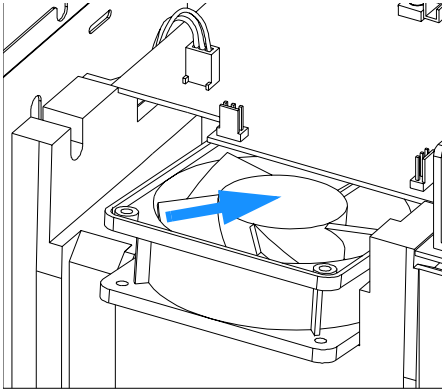
#### CAUTION

The ASM board is sensitive to electrostatic discharge. Always use the ESD strap (see "Using the ESD Strap" on page 106) when handling electronic boards.

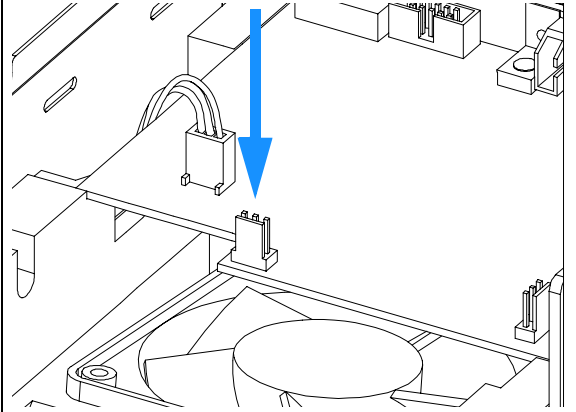




**3** Install the new fan. Ensure the cable is installed as shown.



**4** Connect the fan connector to the ASM board.



**On completion of this procedure:**

- Install the transport assembly ([page 136](#)).
- Install the top cover and foam ([page 132](#)).
- Verify the transport assembly alignment ([page 100](#)).

### ASM Board

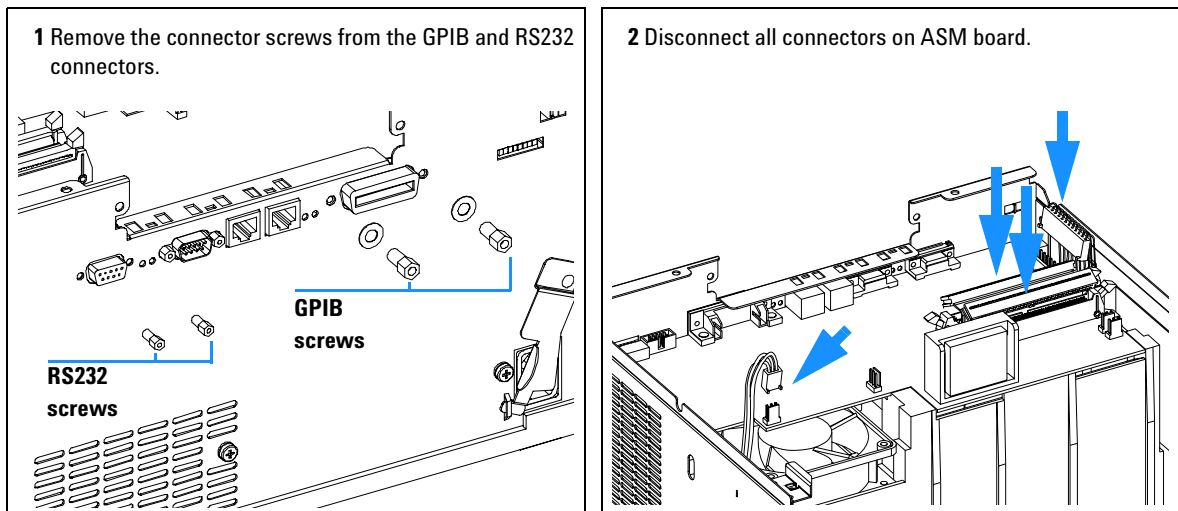
<b>Frequency</b>	When defective
<b>Tools required</b>	5 mm wrench (for remote-connector screws). 7 mm wrench (for GPIB connector screws).
<b>Parts required</b>	ASM board G1313-69520 <i>for G1313A</i> ASM board G1329-69500 <i>for G1329A - G1389A - G2260A</i>
<b>Preparations for this procedure</b>	Remove the top cover and foam ( <a href="#">page 132</a> ). Remove the transport assembly ( <a href="#">page 136</a> ).

#### CAUTION

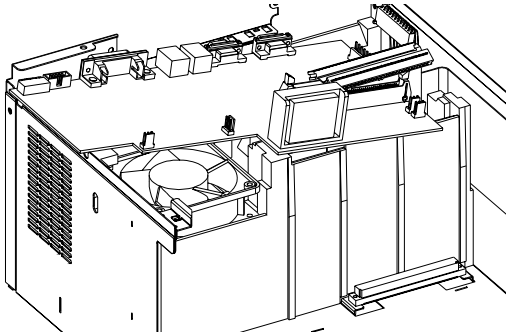
The ASM board is sensitive to electrostatic discharge. Always use the ESD strap (see "Using the ESD Strap" on page 106) when handling electronic boards.

#### NOTE

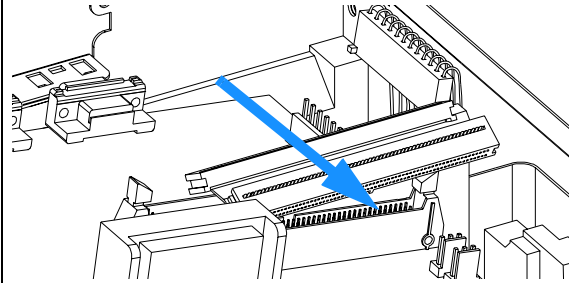
This procedure requires reloading the autosampler firmware, reprogramming of the instrument serial number, and realignment of the gripper.



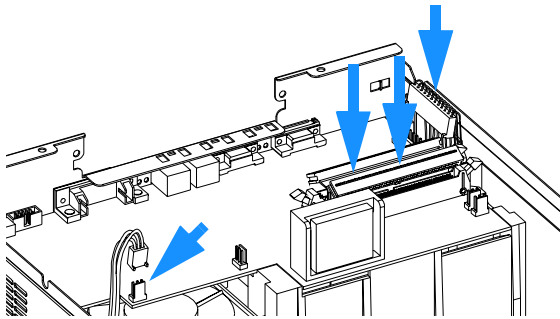
**3** Slide ASM board out of the autosampler.



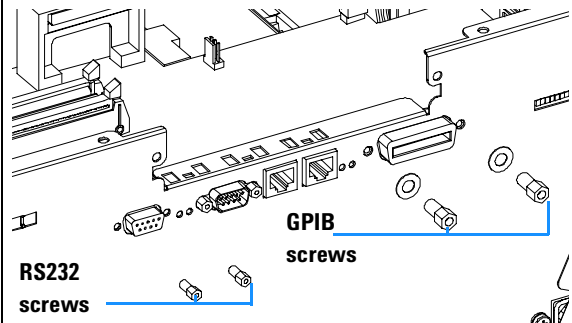
**4** Install new board. Ensure ribbon cables are positioned in the slot in the board.



**5** Reconnect the connectors to the board.



**6** Replace GPIB and RS232 connector screws.



**On completion of this procedure:**

**On the new board check the switch setting of address switch S1, see [Table 75](#) on page 246, or [Table 76](#) on page 247.**

**Note:**

**An incorrect switch setting (e.g., TEST/ BOOT) may cause the autosampler to turn in a basic mode (yellow or red flashing status light). In such a case turn off the pump, re-set the address switches, and turn on the pump again.**

- 7 Install the transport assembly (page 136).
- 8 Install the top cover and foam (page 132).
- 9 Turn on the autosampler.
- 10 Enter the 10-character autosampler serial number. The serial number can be entered using either the control module or the ChemStation, see “Entering the Serial Number using the Control Module” on page 156 or see “Entering the Serial Number using the ChemStation” on page 157.
- 11 Check the firmware revision of the autosampler. If the firmware revision is older than the current firmware revision of the autosampler, update the firmware, see “Replacing the Autosampler Firmware” on page 158

### Entering the Serial Number using the Control Module

- 1 Connect the control module to the autosampler. Turn on the autosampler.
- 2 In the control module, press *System* (F5), then *Records* (F4). Using the up/down arrows, make sure that the autosampler is highlighted.
- 3 Press *FW Update* (F5). Now, press the *m* key. This will display a box which says ‘Update Enter Serial#’.
- 4 Press *Enter*. This will display the box labeled *Serial#*.
- 5 Letters and numbers are created using the up and down arrows. Into the box labeled *Serial#*, enter the 10-character serial number for the autosampler. When the 10-character serial number is entered, press *Enter* to highlight the complete serial number. Then, press *Done* (F6).

#### NOTE

For firmware revisions below A02.00 it is very important never to press *Done* if the *Serial#* box is blank. In this case, the module can no longer be recognized by either the control module or the ChemStation. The main board must then be replaced.

- 6 Turn the autosampler off, then on again. The *Records* screen should display the correct serial number for this module.
- 7 If a ChemStation is also connected, re-boot the ChemStation now as well.

### Entering the Serial Number using the ChemStation

Module serial numbers are entered by typing specific commands into the command line at the bottom of the main user interface screen.

- 1 To enter a module serial number, type the following command into the command line:

```
print sendmodule$(lals, "ser YYYYYYYYYY")
```

Where: YYYYYYYYYY is the 10-character serial number of the module in question.

#### NOTE

The first two characters are letters, which should be capitalized.

---

The reply line will respond with RA 0000 SER followed by the module serial number you just entered.

- 2 Turn off the autosampler, then on again. Then, re-boot the ChemStation. If the serial number you have just entered is different than the original module serial number, you will be given the opportunity to edit the configure Agilent 1100 access screen during the re-boot of the ChemStation.
- 3 After boot-up, the serial number you have just entered can be seen under the *Instrument menu* of the main user interface screen. The serial number of the autosampler can also be seen by typing the following command into the command line:

```
print sendmodule$(lals, "ser?")
```

The reply line will give the module serial number.

### Replacing the Autosampler Firmware

The installation of new firmware is required

- if new version solves problems of currently installed version.
- if after exchange of the mainboard (ASM) the version on board is older than previous installed one.

To upgrade the autosampler firmware the following steps have to be performed:

- Load the firmware into the autosampler, see the help system of your user interface.

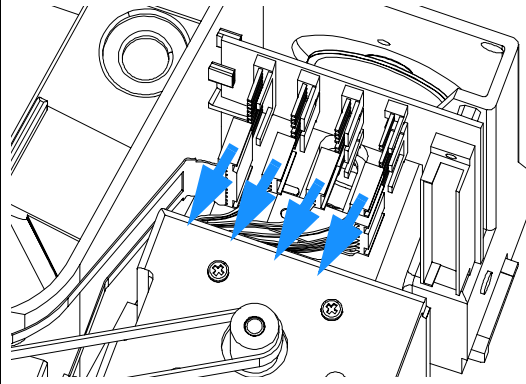
## SUD Board

<b>Frequency</b>	When defective.
<b>Tools required</b>	Pozidrive No. 1 screwdriver.
<b>Parts required</b>	SUD board G1313-66503.
<b>Preparations for this procedure</b>	Remove the top cover ( <a href="#">page 132</a> ). Remove the transport assembly ( <a href="#">page 136</a> ). Remove the sampling unit ( <a href="#">page 138</a> ).

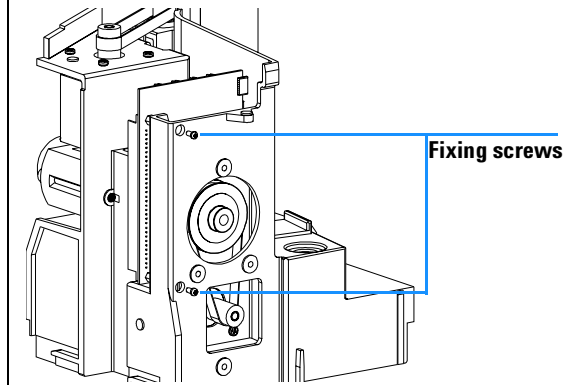
### CAUTION

Take care not to damage the flex board when removing the SUD board.

1 Disconnect all connectors from the SUD board.

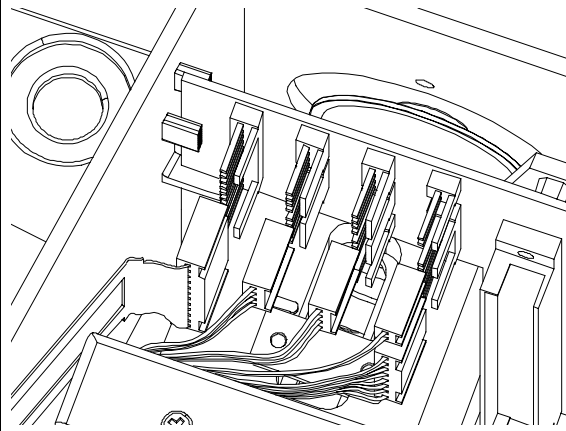


2 Remove the two fixing screws, and lift out the board.

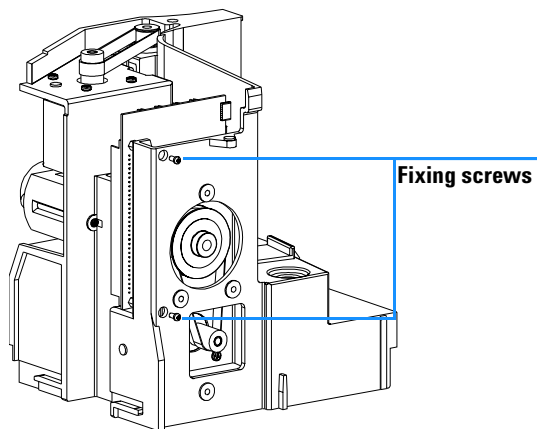


## 4 Repairing the Autosampler

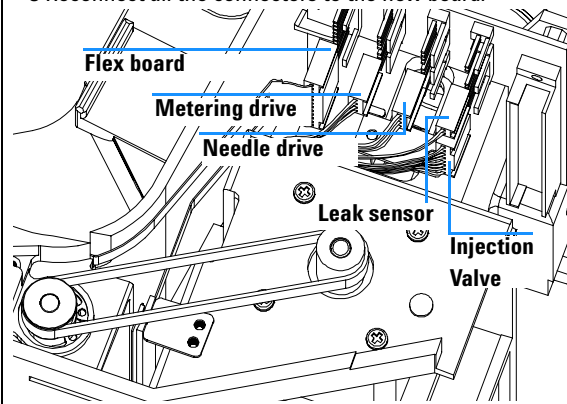
**3** Install the new board. Ensure the board is positioned between the board guide.



**4** Secure the board in place with the two screws.



**5** Reconnect all the connectors to the new board.



**On completion of this procedure:**

- Install the sampling unit ([page 138](#)).
- Install the transport assembly ([page 136](#)).
- Install the top cover ([page 132](#)). Verify the transport assembly alignment ([page 100](#)).



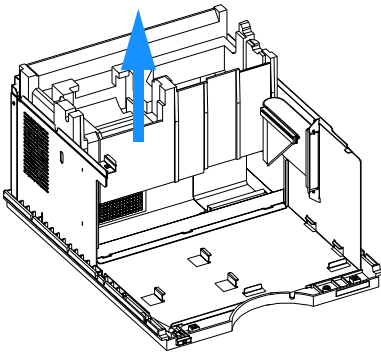
## Power Supply

<b>Frequency</b>	When defective
<b>Tools required</b>	Pozidrive No. 1 screwdriver
<b>Parts required</b>	Power supply 0950-2528.
<b>Preparations for this procedure</b>	Remove the top cover (page 132). Remove the transport assembly (page 136). Remove the sampling unit (page 138). Remove the ASM board (page 154). Remove the fan (page 152).

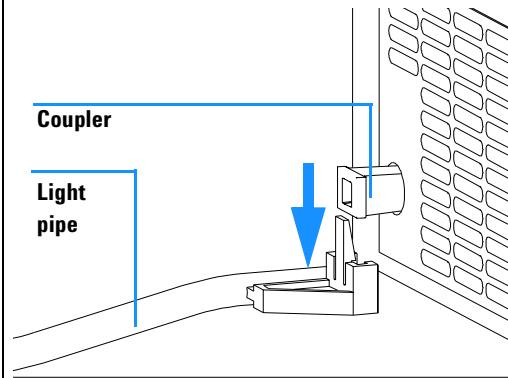
### CAUTION

The ASM board is sensitive to electrostatic discharge. Always use the ESD strap (see "Using the ESD Strap" on page 106) when handling electronic boards.

1 Remove the bottom foam.

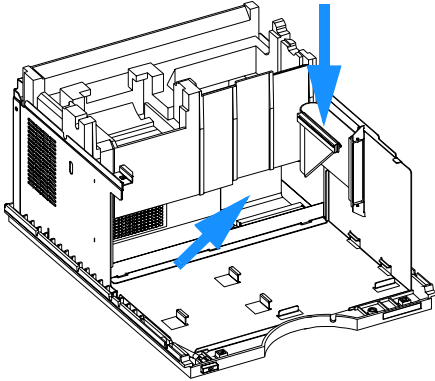


2 Remove the power switch light pipe from the coupler.





**9** Install the bottom foam. Ensure the cables are positioned as shown.



**On completion of this procedure:**

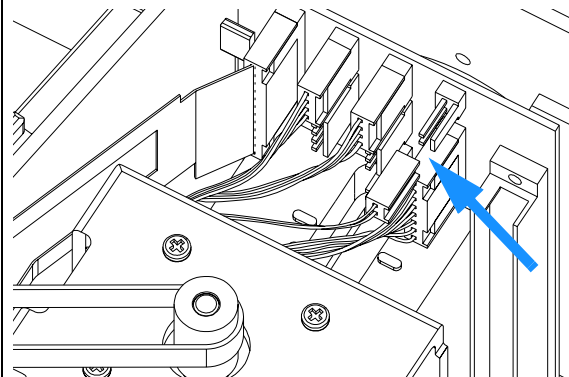
- Install the ASM board ([page 154](#)).
- Install the fan ([page 152](#)). Install the sampling unit ([page 138](#)).

## 4 Repairing the Autosampler

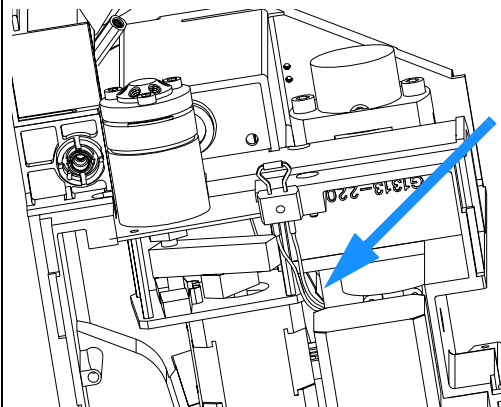
### Leak Sensor

<b>Frequency</b>	When defective
<b>Tools required</b>	None.
<b>Parts required</b>	Leak sensor 5061-3356.
<b>Preparations for this procedure</b>	Remove the top cover ( <a href="#">page 132</a> ). Remove the transport assembly ( <a href="#">page 136</a> ). Remove the sampling unit ( <a href="#">page 138</a> ).

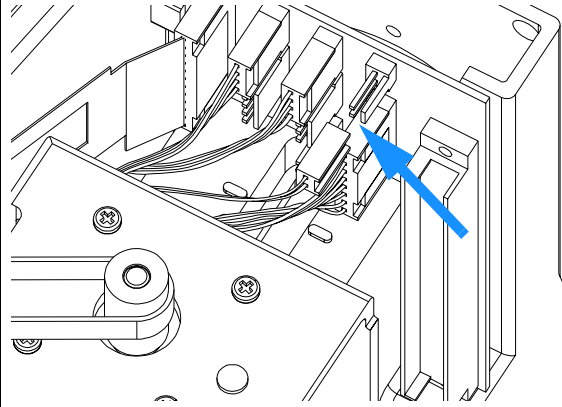
**1** Disconnect the leak sensor from the SUD board (labelled "leak sensor"). Remove the sensor.



**2** Feed the cable of the new sensor through the base of the sampling unit to the SUD board.



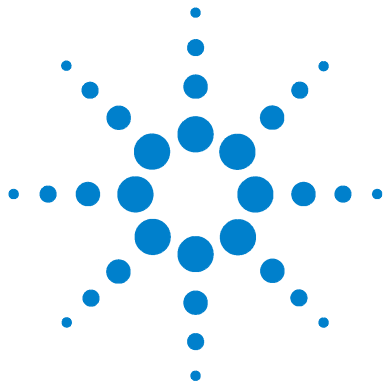
**3** Connect the connector to the connector (labelled “leak sensor”).



**On completion of this procedure:**

- Install the sampling unit ([page 138](#)).
- Install the transport assembly ([page 136](#)).
- Install the top cover ([page 132](#)). Verify the transport assembly alignment ([page 100](#)).

## **4 Repairing the Autosampler**



## 5 Parts and Materials

Main Assemblies	168
Sampling Unit Assembly	171
Analytical-Head Assembly	174
Injection-Valve Assembly	177
Sheet Metal Kit	179
Cover Parts	180
Foam Parts	181
Power and Status Light Pipes	182
Leak System Parts	183
Vial Trays	184
Autosampler Accessory Kit G1313-68705	186
Thermostatted Autosampler Accessory Kit G1329-68705	187
Micro Thermostatted Autosampler Accessory Kit G1329-68715	188
Preparative ALS Accessory Kit G2260-68705	189
Maintenance Kit G1313-68709	190
Multi-Draw Kit G1313-68711	191
900 µl Injection Upgrade Kit G1363A for G1313A / 29A	192
External Tray G1313-60004	193
Cable Overview	194
RS-232 Cable Kit	211
LAN Cables	212



## Main Assemblies

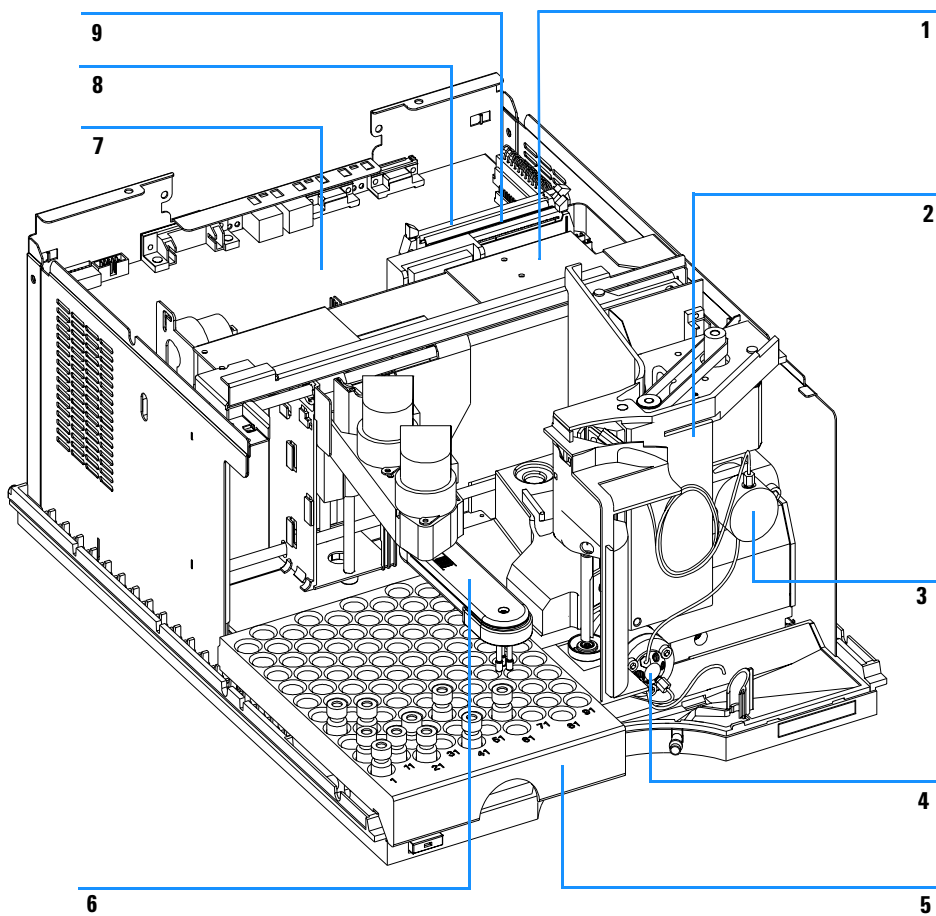
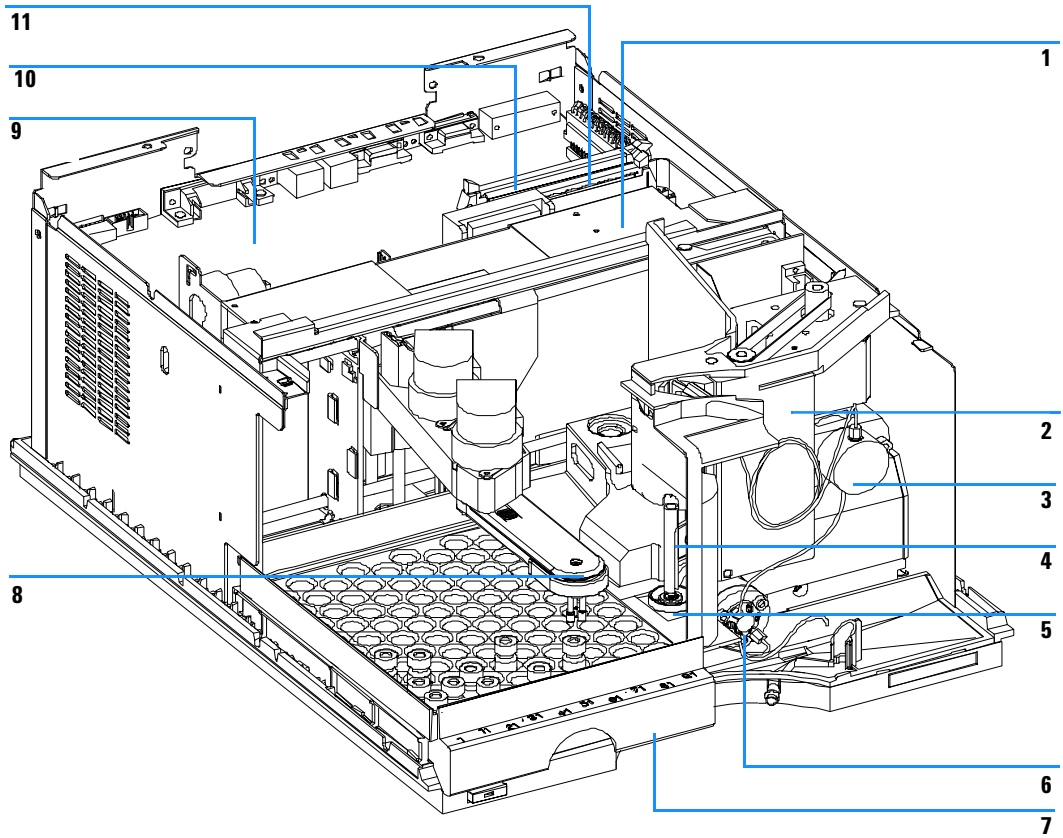


Figure 19 Autosampler Main Assemblies





**Table 20** Autosampler Main Assemblies

Item	Description	Part Number
1	Transport assembly for G1313A Transport assembly for G1329A-1389A-2260A	G1313-60009 G1329-60009
2	Sampling unit assembly for G1313A Sampling unit assembly for G1329A Sampling unit assembly for G1389A Sampling unit assembly for G2260A (The assy comes without injection valve and analytical head)	G1313-60008 G1329-60008 G1329-60018 G2260-60008

**Table 20** Autosampler Main Assemblies (continued)

Item	Description	Part Number
3	Analytical head assembly (100 µl) for G1313-29A	01078-60003
	Analytical head assembly (40 µl) for G1389A	G1377-60013
	Preparative head assembly (900 µl) for G1313-29A (P<200Bar)	G1313-60007
	Preparative head assembly (900 µl) for G2260A (P<400Bar)	G2260-60007
4	Injection valve assembly for G1313-29A	0101-0921
	Injection valve assembly for G1389A	0101-1050
	Injection valve assembly for G2260A	0101-1267
5	Vial tray, thermostatted (see page 184)	G1329-60001
6	Gripper assembly	G1313-60010
7	Autosampler Main Board (ASM) for G1313	G1313-69520
	Autosampler Main Board (ASM) for G1329A-1389A-2260A	G1329-69500
	Standoff - GPIB connector (part not shown)	0380-0643
	Standoff - remote connector (part not shown)	1251-7788
8	Ribbon cable, sample transport	G1313-81601
9	Ribbon cable, sampling unit	G1313-81602
	Sampler - TCC cap (380 mm 0.1 mm id) for G1329A	01090-87306
	Sampler - TCC cap (500 mm 0.05 mm id) for G1389A 20 µl FS	G1375-87304
	Sampler - TCC cap (500 mm 0.075 mm id) for G1389A 100 µl FS	G1375-87311
	Sampler - Column cap (600 mm, 0.5 mm id) for G2260A	G2260-87300
	Power supply assembly (part not shown)	0950-2528
	Screw M4, 8 mm lg - power supply (part not shown)	0515-0910
	BCD board (not shown)	G1351-68701
	Cable, autosampler to ALS thermostat (part not shown)	G1330-81600

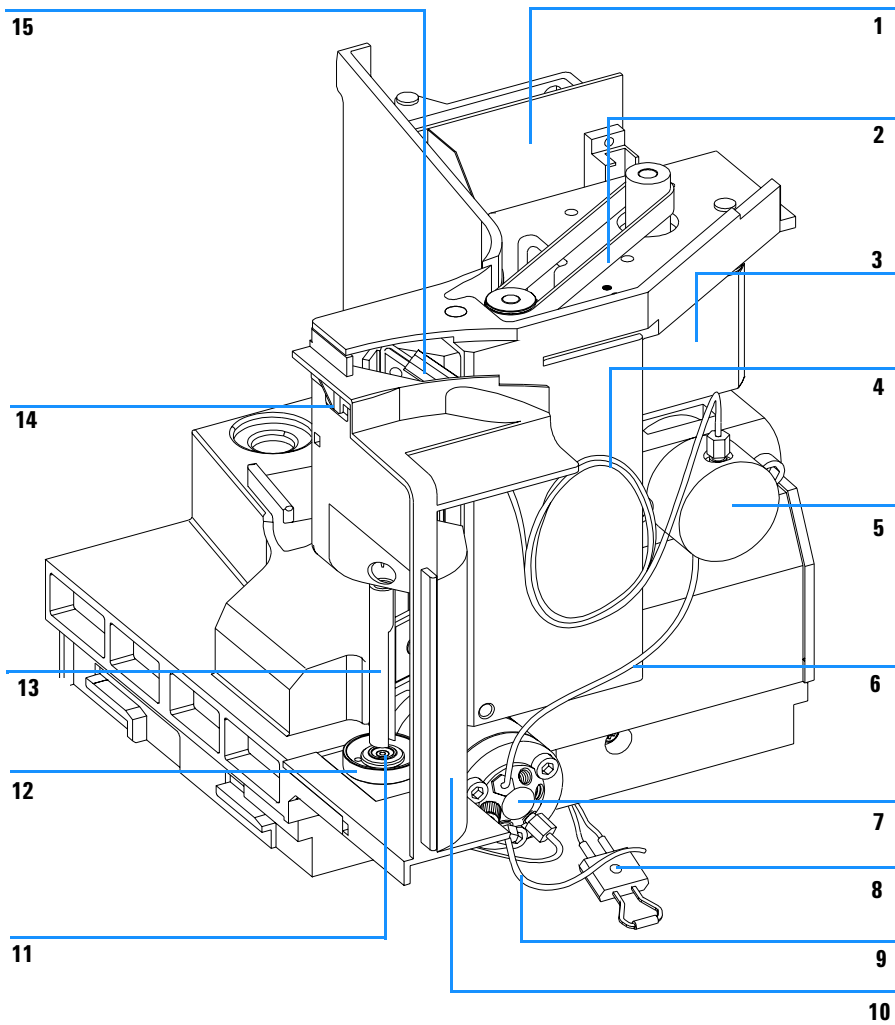
## Sampling Unit Assembly

**Table 21** Autosampler Sampling Unit Assembly

Item	Description	Part Number
	Sampling unit assembly <i>for G1313A</i>	G1313-60008
	Sampling unit assembly <i>for G1329A</i>	G1329-60008
	Sampling unit assembly <i>for G1389A</i>	G1329-60018
	Sampling unit assembly <i>for G2260A</i> (The assy comes without injection valve and analytical head)	G2260-60008
1	Sampling unit connector board (SUD)	G1313-66503
2	Belt gear <i>for metering unit and needle arm</i>	1500-0697
3	Stepper motor <i>for metering unit and needle arm</i>	5062-8590
4	Loop capillary (100 µl) <i>for G1313-29A / G2260A</i>	01078-87302
	Loop capillary (40 µl) <i>for G1389A</i>	G1329-87302
	Loop capillary (8 µl) <i>for G1389A</i>	G1375-87303
	Loop ext. capillary (900 µl) <i>for G1313-29A / G2260A</i>	G1313-87303
	Union for (900 µl) loop extension capillary	5022-2133
5	Analytical head assembly (100 µl) <i>for G1313-29A</i>	01078-60003
	Analytical head assembly (40 µl) <i>for G1389A</i>	G1377-60013
	Preparative head assembly (900 µl) <i>for G1313-29A (P&lt;200Bar)</i>	G1313-60007
	Preparative head assembly (900 µl) <i>for G2260A (P&lt;400Bar)</i>	G2260-60007
6	Inj. valve - Anal. head cap (160 mm 0.25 mm) <i>for G1313-29A</i>	G1313-87301
	Inj. valve - Anal. head cap (200 mm 0.05 mm) <i>for G1389A 20 µl FS</i>	G1375-87302
	Inj. valve - Anal. head cap (200 mm 0.10 mm) <i>for G1389A 100 µl FS</i>	G1375-87312
	Inj. valve - Prep. head cap (160 mm 0.50 mm) <i>for G2260A</i>	G2258-87301
7	Injection valve assembly <i>for G1313-29A</i>	0101-0921
	Injection valve assembly <i>for G1389A</i>	0101-1050
	Injection valve assembly <i>for G2260A</i>	0101-1267
8	Leak sensor	5061-3356
9	Waste tube injection valve assy (120 mm) <i>for G1313-29A / G2260A</i>	G1313-87300
	Waste tube injection valve assy (120 mm 0.25 mm) <i>for G1389A</i>	G1377-87301
10	Safety cover	G1329-44105

**Table 21** Autosampler Sampling Unit Assembly (continued)

<b>Item</b>	<b>Description</b>	<b>Part Number</b>
11	Needle-seat assy (0.17 mm i.d 2.3 µl) <i>for G1313-29A (STANDARD)</i>	G1313-87101
	Needle-seat assy (0.12 mm i.d 1.2 µl) <i>for G1313-29A</i>	G1313-87103
	Needle seat assy (0.10 mm i.d 1.2 µl) <i>for G1389A (STANDARD)</i>	G1329-87101
	Needle seat assy (0.05 mm i.d 0.3 µl) <i>for G1389A</i>	G1329-87103
	Needle-seat assy (0.50 mm i.d 20 µl) <i>for G2260A</i>	G2260-87101
12	Seat adapter	G1313-43204
13	Safety flap	G1313-44106
14	Flex board	G1313-68715
15	Needle assembly <i>for G1313-87101 or G1313-87103 needle-seat</i>	G1313-87201
	Needle assembly <i>for G1329-87101 or G1329-87103 needle seat</i>	G1329-80001
	Needle assembly (900 µl loop capillary) <i>for G1313-87101 needle seat</i>	G1313-87202
	Needle assembly (900 µl loop capillary) <i>for G2260-87101 needle-seat</i>	G2260-87201
	Clamp Kit (includes needle clamp and 2 x clamp screw)	G1313-68713



**Figure 20** Autosampler Sampling Unit Assembly

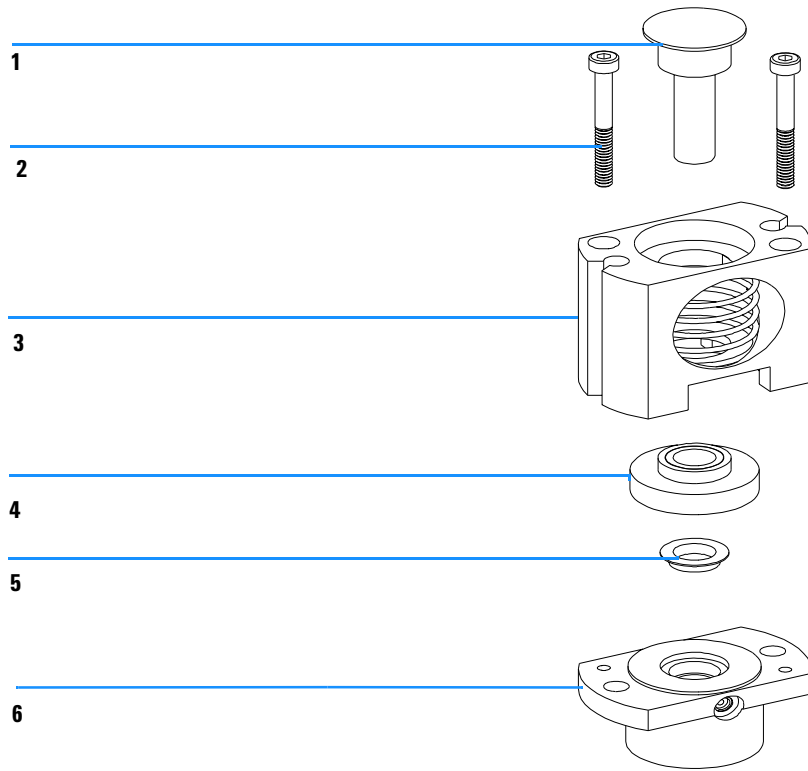
## Analytical-Head Assembly

**Table 22** Analytical-Head Assembly (100 µl) for G1313A / G1329A

Item	Description	Part Number
	Analytical head assembly, includes items 1 – 6	01078-60003
1	Screws	0515-0850
2	Plunger assembly	5063-6586
3	Adapter	01078-23202
4	Support seal assembly	5001-3739
5	Metering seal (pack of 2)	5063-6589
6	Head body	01078-27710
	Screw M5, 60 mm lg, for mounting of assembly	0515-2118

**Table 23** Analytical-Head Assembly (40 µl) for G1389A

Item	Description	Part Number
	Micro Analytical head assembly 40 µl, includes items 1 – 6	G1377-60013
1	Micro Plunger assembly	5064-8293
2	Screws	0515-0850
3	Adapter	01078-23202
4	Micro seal support assembly	G1377-60002
5	Metering seal (pack of 1)	5022-2175
6	Head body	G1377-27700
	Screw M5, 60 mm lg, for mounting of assembly	0515-2118



**Figure 21** Analytical-Head Assembly

**Table 24** Preparative-Head Assembly (900 µl) for G1313A / G1329A

Item	Description	Part Number
	Analytical head assembly 900 µl <sup>*</sup> , includes items 1 – 6	G1313-60007
1	Plunger assembly, 900 µl	5062-8587
2	Screws	0515-0850
3	Adapter	01078-23202
4	Support seal assembly, 900 µl	5001-3764
5	Metering seal, 900 µl	0905-1294
6	Head body, 900 µl	G1313-27700
	Screw M5, 60 mm lg, for mounting of assembly	0515-2118

\* This head is limited to 200 Bars

**Table 25** Preparative-Head Assembly (900 µl) for G2260A

Item	Description	Part Number
	Analytical head assembly 900 µl <sup>*</sup> , includes items 1 – 6	G2260-60007
1	Plunger assembly, 900 µl	5062-8587
2	Screws	0515-0850
3	Adapter	01078-23202
4	Support seal assembly, 900 µl	5001-3764
5	Metering seal, 900 µl	0905-1294
6	Head body, 900 µl	G2260-27700
	Screw M5, 60 mm lg, for mounting of assembly	0515-2118

\* This head is limited to 400 Bars. It can only be assembled on a sampling unit with the description "supports 900 µl at 400 Bar.



## Injection-Valve Assembly

**Table 26** Injection-Valve Assembly for G1313A / G1329A

Item	Description	Part Number
1	Injection-valve assembly, includes items 1 – 6	0101-0921
2	Isolation seal	0100-1852
3	Rotor seal (Vespel)	0100-1853
3	Rotor seal (Tefzel)	0100-1849
4	Stator face	0100-1851
5	Stator head	0100-1850
6	Stator screws	1535-4857

**Table 27** Micro Injection-Valve Assembly for G1389A

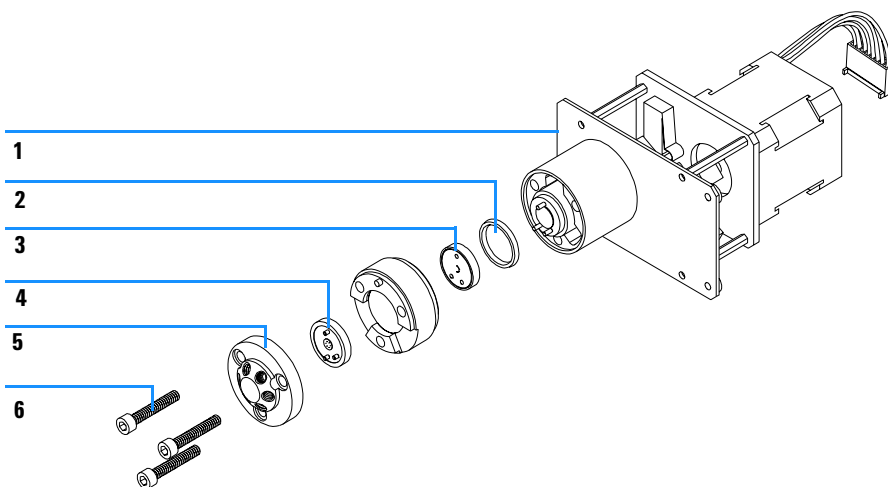
The micro injection valve assembly has no ceramic stator face

Item	Description	Part Number
1	Micro Inj.-valve assy, incl. items 1 – 2 – 3 – 5 – 6	0101-1050
2	Isolation seal	0100-1852
3	Micro rotor seal (Vespel)	0100-2088
5	Micro Stator head	0100-2089
6	Stator screws	1535-4857

**Table 28** Preparative Injection-Valve Assembly for G2260A

Item	Description	Part Number
1	MBB <sup>*</sup> -Injection-valve assembly, includes items1 – 6	0101-1267
2	Isolation seal	0100-1852
3 - 4	Rotor seal (PEEK) + Stator face (PEEK) kit	0101-1268
5	Stator head	0100-2195
6	Stator screws	1535-4857

\* MBB (Make Before Brake) is a trademark by Rheodyne

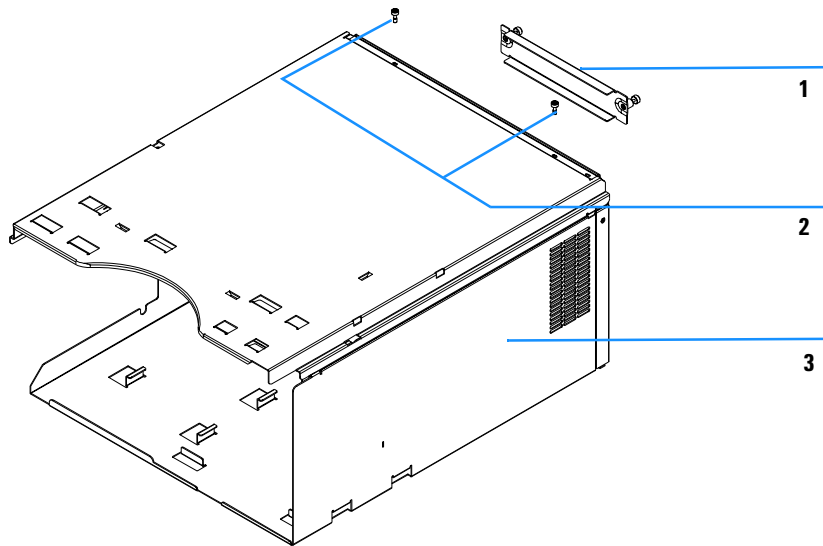


**Figure 22** Injection-Valve Assembly

## Sheet Metal Kit

**Table 29** Sheet Metal

Item	Description	Part Number
1	Slot cover	5001-3772
2	Screw cover	5022-2112
3	Autosampler Sheet metal kit for G1313A Autosampler Sheet metal kit for G1329A / G1389A / G2260A	G1313-68701 G1329-68701



**Figure 23** Sheet Metal Kit

## Cover Parts

Table 30 Covers

Item	Description	Part Number
1	Autosampler Cover kit for G1313A Autosampler Cover kit for G1329A / G1389A / G2260A (include base, side panels and top cover)	G1313-68703 G1329-68703
2	Name plate for Agilent 1100 Series	5042-1381
3	Transparent front cover	G1313-68704
4	Door repair kit (includes transparent side and front door)	G1329-68707
5	Light protection kit (includes opaque side and front door, opaque front cover)	G1329-68708
	Cabinet upgrade kit (includes side panels, top cover, transparent side and front door, front cover and side insulation cover for cooled autosampler)	G1329-68706

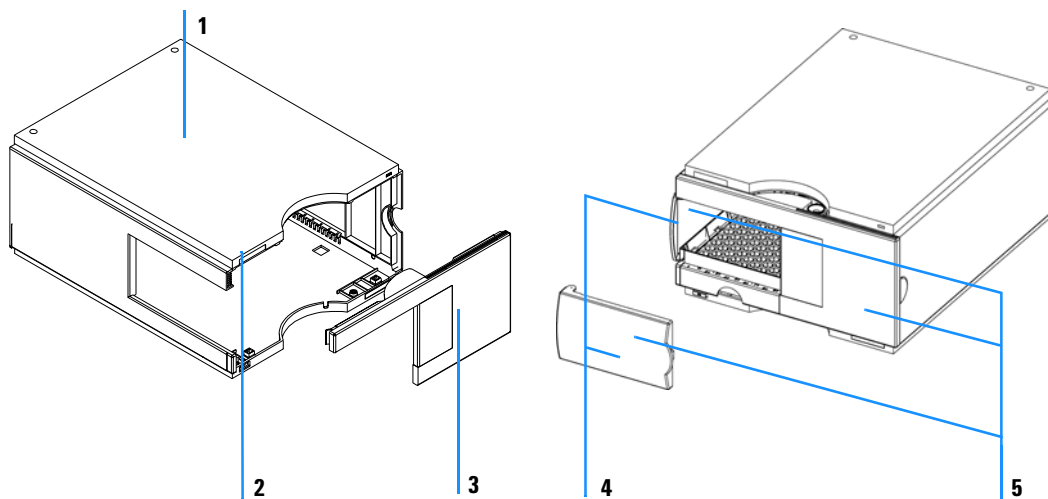
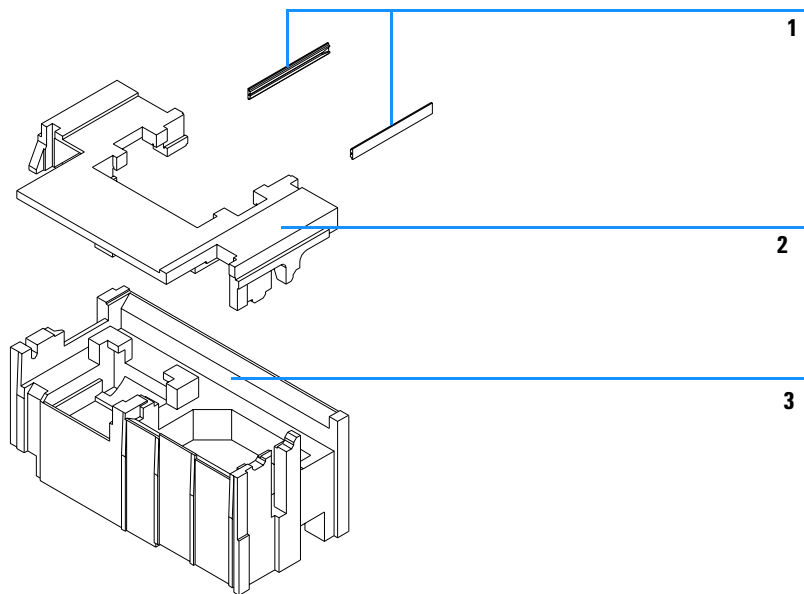


Figure 24 Cover Parts

## Foam Parts

**Table 31** Foam Parts

Item	Description	Part Number
	Foam kit, includes items 2 and 3	<a href="#">G1313-68702</a>
1	Board guides	<a href="#">5041-8395</a>
2	Top foam	Order foam kit
3	Bottom foam	Order foam kit

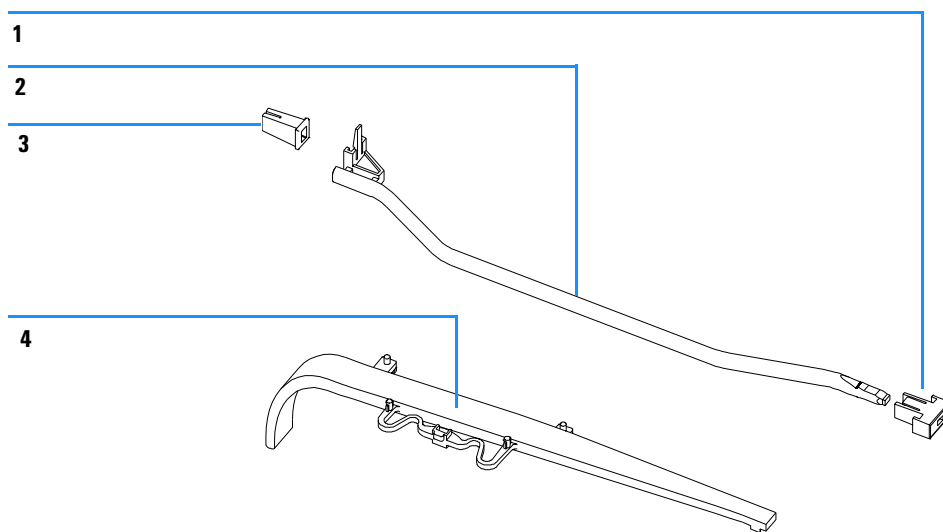


**Figure 25** Foam Parts

## Power and Status Light Pipes

**Table 32** Power and Status Light Pipes

Item	Description	Part Number
1	Power switch button	5041-8381
2	Light pipe — power switch	5041-8382
3	Power switch coupler	5041-8383
4	Light pipe — status lamp	5041-8384



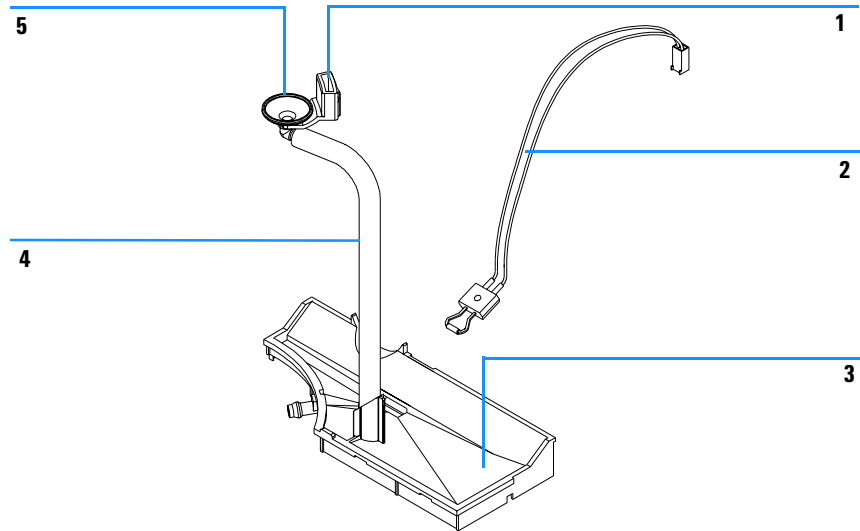
**Figure 26** Power and Status Light Pipes

## Leak System Parts

**Table 33** Leak System Parts

Item	Description	Part Number
1	Leak funnel holder	5041-8389
2	Leak sensor	5061-3356
3	Leak plane	G1313-44501
4	Leak tubing 120 mm*	5062-2463
5	Leak funnel	5041-8388

\* reorder gives 5 m

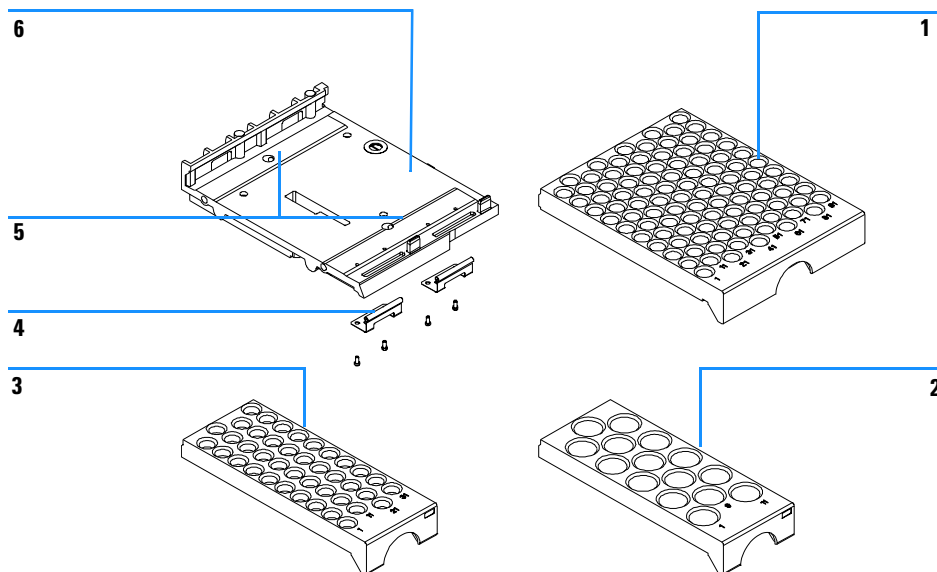


**Figure 27** Leak System Parts

## Vial Trays

**Table 34** Autosampler Vial Trays and Tray Base

Item	Description	Part Number
1	Tray for 100 × 2-ml vials	G1313-44500
2	Halftray for 15 × 6-ml vials	G1313-44503
3	Halftray for 40 × 2-ml vials	G1313-44502
4	Spring	G1313-09101
5	Spring stud	0570-1574
6	Tray base for G1313A (includes items 4, 5).	G1313-60002

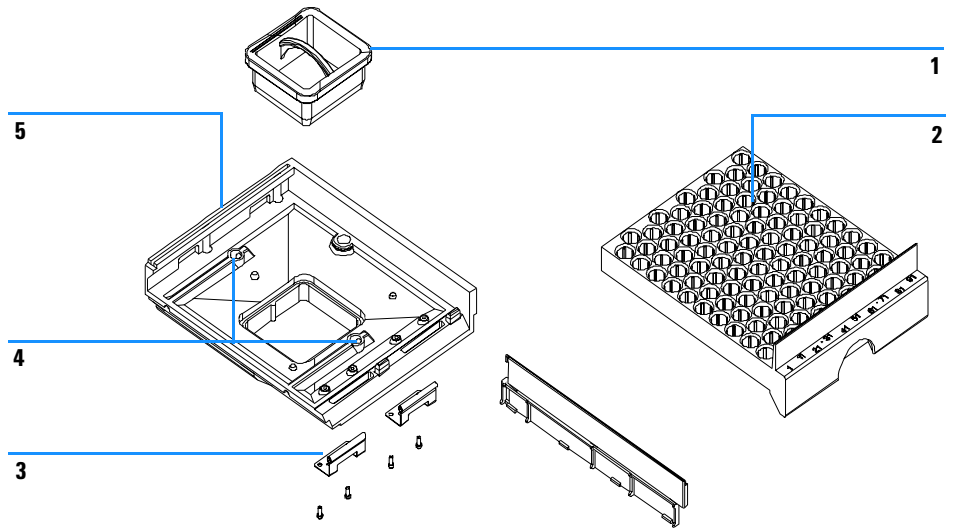


**Figure 28** Vial Trays and Tray Base



**Table 35** Thermostatted Autosampler Vial Trays and Tray Base

Item	Description	Part Number
1	Adapter, air channel	G1329-43200
2	Tray for 100 × 2-ml vials, thermostattable	G1329-60001
3	Spring	G1313-09101
4	Tray base for G1329A /G1389A / G2260A (includes items 4, 5).	G1329-60000
5	Spring stud	0570-1574



**Figure 29** Thermostatted Autosampler Vial Trays and Tray Base

## Autosampler Accessory Kit [G1313-68705](#)

**Table 36** G1313A - Autosampler Accessory Kit Contents [G1313-68705](#)

Description	Part Number
Tubing assembly	no PN
Filter promo kit	no PN
CAN cable	<a href="#">5181-1516</a>
Screw cap vials, clear 100/pk	<a href="#">5182-0714</a>
Blue screw caps 100/pk	<a href="#">5182-0717</a>
Label halftray	no PN
Vial instruction sheet	no PN
Wrenches 1/4 - 5/16 inch	<a href="#">8710-0510</a>
Rheotool socket wrench 1/4 inch	<a href="#">8710-2391</a>
Hex key 4 mm, 15 cm long, T-handle	<a href="#">8710-2392</a>
Hex key 9/64 mm, 15 cm long, T- handle	<a href="#">8710-2394</a>
Hex key 2.5 mm, 15 cm long, straight handle	<a href="#">8710-2412</a>
ESD wrist strap	no PN
Finger caps (x3)*	<a href="#">5063-6506</a>
Tray for 40 x 2 ml vials	<a href="#">G1313-44502</a>
Tray for 15 x 6 ml vials	<a href="#">G1313-44503</a>
Capillary 0.17 mm 180 mm	<a href="#">G1313-87305</a>

\* Reorder gives pack of 15

## Thermostatted Autosampler Accessory Kit [G1329-68705](#)

**Table 37** G1329A - Thermostatted Autosampler Accessory Kit Contents [G1329-68705](#)

Description	Part Number
Tubing assembly	no PN
Filter promo kit	no PN
CAN cable, 1 m long	<a href="#">5181-1519</a>
Screw cap vials, clear 100/pk	<a href="#">5182-0714</a>
Blue screw caps 100/pk	<a href="#">5182-0717</a>
Label halftray	no PN
Vial instruction sheet	no PN
Wrenches 1/4 - 5/16 inch	<a href="#">8710-0510</a>
Rheotool socket wrench 1/4 inch	<a href="#">8710-2391</a>
Hex key 4 mm, 15 cm long, T-handle	<a href="#">8710-2392</a>
Hex key 9/64 mm, 15 cm long, T-handle	<a href="#">8710-2394</a>
Hex key 2.5 mm, 15 cm long, straight handle	<a href="#">8710-2412</a>
ESD wrist strap	no PN
Finger caps x3 (reorder gives pack of 15)	<a href="#">5063-6506</a>
Front door cooled autosampler	no PN
Air channel adapter	<a href="#">G1329-43200</a>
Cover insulation	no PN
Capillary 0.17 mm, 900 mm	<a href="#">G1329-87300</a>
Capillary heat exchanger	<a href="#">01090-87306</a>
Note for 1100 Series Autosampler door upgrade	no PN

## Micro Thermostatted Autosampler Accessory Kit [G1329-68715](#)

**Table 38** G1389A - Micro Thermostatted Autosampler Accessory Kit Contents  
[G1329-68715](#)

Description	Part Number
Tubing assembly	no PN
CAN cable, 1 m long	<a href="#">5181-1519</a>
Screw cap vials, clear 100/pk	<a href="#">5182-0714</a>
Blue screw caps 100/pk	<a href="#">5182-0717</a>
Label halftray	no PN
Fitting	<a href="#">5061-3303</a>
Hex Key	<a href="#">8710-0060</a>
Wrench 4 mm both ends	<a href="#">8710-1534</a>
Wrenches 1/4 - 5/16 inch	<a href="#">8710-0510</a>
Rheotool socket wrench 1/4 inch	<a href="#">8710-2391</a>
Hex key 4 mm, 15 cm long, T-handle	<a href="#">8710-2392</a>
Hex key 9/64 mm, 15 cm long, T- handle	<a href="#">8710-2394</a>
Hex key 2.5 mm, 15 cm long, straight handle	<a href="#">8710-2412</a>
ESD wrist strap	no PN
Finger caps x3 (reorder gives pack of 15)	<a href="#">5063-6506</a>
Torque adapter	<a href="#">G1315-45003</a>
Front door cooled autosampler	no PN
Air channel adapter	<a href="#">G1329-43200</a>
Extended loop capillary 0.25 mm, 180 mm	<a href="#">G1329-87302</a>
Fused silica capillary 0.050 mm, 500 mm	<a href="#">G1375-87304</a>

## Preparative ALS Accessory Kit [G2260-68705](#)

**Table 39** G2260A - Preparative Autosampler Accessory Kit Contents [G2260-68705](#)

Description	Part Number
Tubing assembly	no PN
Filter promo kit	no PN
CAN cable, 1 m long	<a href="#">5181-1519</a>
Screw cap vials, clear 100/pk	<a href="#">5182-0714</a>
Blue screw caps 100/pk	<a href="#">5182-0717</a>
Label halftray	no PN
Wrenches 1/4 - 5/16 inch	<a href="#">8710-0510</a>
Rheotool socket wrench 1/4 inch	<a href="#">8710-2391</a>
Hex key 4 mm, 15 cm long, T-handle	<a href="#">8710-2392</a>
Hex key 9/64 mm, 15 cm long, T- handle	<a href="#">8710-2394</a>
Hex key 2.5 mm, 15 cm long, straight handle	<a href="#">8710-2412</a>
ESD wrist strap	no PN
Finger caps x3 (reorder gives pack of 15)	<a href="#">5063-6506</a>
Front door cooled autosampler	no PN
Air channel adapter	<a href="#">G1329-43200</a>
Tray for 15 x 6 ml vials (x2)	<a href="#">G1313-44503</a>
Union, loop extension	<a href="#">5022-2133</a>
Seat extension capillary (500 µl)	<a href="#">G1313-87307</a>
Seat extension capillary (1500 µl)	<a href="#">G1313-87308</a>
Sampler - Column capillary	<a href="#">G2260-87300</a>
Pump - Sampler capillary	<a href="#">G2260-87301</a>

## Maintenance Kit **G1313-68709**

**Table 40** Maintenance Kit

<b>Item</b>	<b>Description</b>	<b>Part Number</b>
1	Rotor seal (Vespel)	0100-1853
2	Needle assembly	G1313-87201
3	Needle-seat assembly	G1313-87101
4	Metering seal (pack of 2)	5063-6589
5	Finger caps (pack of 15)	5063-6506

## Multi-Draw Kit **G1313-68711**

**Table 41** Multi-Draw Kit

<b>Item</b>	<b>Description</b>	<b>Part Number</b>
1	Seat capillary, 500 $\mu$ l, 0.5 mm id	<a href="#">G1313-87307</a>
2	Seat capillary, 1500 $\mu$ l, 0.9 mm id	<a href="#">G1313-87308</a>
3	Union	<a href="#">0100-0900</a>

## 900 µl Injection Upgrade Kit G1363A for G1313A / 29A

**Table 42** 900 µl Injection Upgrade Kit

Item	Description	Part Number
1	Analytical Head, 900 µl	<a href="#">G1313-60007</a>
2	Loop Extension, 900 µl	<a href="#">G1313-87303</a>
3	Union, loop extension	<a href="#">5022-2133</a>
4	Needle, 900 µl	<a href="#">G1313-87202</a>



## External Tray **G1313-60004**

**Table 43** External Tray

<b>Item</b>	<b>Description</b>	<b>Part Number</b>
1	External tray	<a href="#">G1313-60004</a>
2	Disposal tube	<a href="#">G1313-27302</a>

## Cable Overview

**WARNING**

Never use cables other than the ones supplied by Agilent Technologies to ensure proper functionality and compliance with safety or EMC regulations.

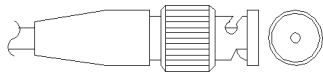
**Table 44** Cables Overview

Type	Description	Part Number
Analog cables	3390/2/3 integrators	01040-60101
	3394/6 integrators	35900-60750
	Agilent 35900A A/D converter	35900-60750
	General purpose (spade lugs)	01046-60105
Remote cables	3390 integrator	01046-60203
	3392/3 integrators	01046-60206
	3394 integrator	01046-60210
	3396A (Series I) integrator	03394-60600
	3396 Series II / 3395A integrator, see <a href="#">page 201</a>	
	3396 Series III / 3395B integrator	03396-61010
	HP 1050 modules / HP 1046A FLD	5061-3378
	HP 1046A FLD	5061-3378
	Agilent 35900A A/D converter	5061-3378
	HP 1040 diode-array detector	01046-60202
	HP 1090 liquid chromatographs	01046-60202
	Signal distribution module	01046-60202
<b>BCD cables</b>	3392/3 integrators	18594-60510

**Table 44** Cables Overview (continued)

<b>Type</b>	<b>Description</b>	<b>Part Number</b>
	3396 integrator	03396-60560
	General purpose (spade Lugs)	18594-60520
<b>Auxiliary</b>	Agilent 1100 Series vacuum degasser	G1322-61600
<b>CAN cables</b>	Agilent 1100 module to module, 0.5m lg	5181-1516
	Agilent 1100 module to module, 1m lg	5181-1519
	Agilent 1100 module to control module	G1323-81600
<b>External contacts</b>	Agilent 1100 Series interface board to general purpose	G1103-61611
<b>GPIB cable</b>	Agilent 1100 module to ChemStation, 1 m	10833A
	Agilent 1100 module to ChemStation, 2 m	10833B
<b>RS-232 cable</b>	Agilent 1100 module to a computer This kit contains a 9-pin female to 9-pin female Null Modem (printer) cable and one adapter.	34398A
<b>LAN cable</b>	Twisted pair cross over LAN cable, 10 feet long (for point to point connection)	5183-4649
	Category 5 UTP cable, 8 m long (for hub connections)	G1530-61480

## Analog Cables



One end of these cables provides a BNC connector to be connected to Agilent 1100 Series modules. The other end depends on the instrument to which connection is being made.

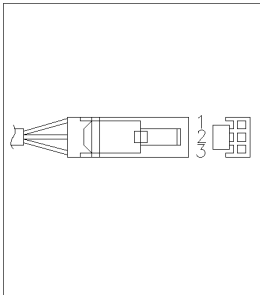
### Agilent 1100 to 3390/2/3 Integrators

Table 45

Connector <b>01040-60101</b>	Pin <b>3390/2/3</b>	Pin <b>Agilent 1100</b>	Signal Name
	1	Shield	Ground
	2		Not connected
	3	Center	Signal +
	4		Connected to pin 6
	5	Shield	Analog -
	6		Connected to pin 4
	7		Key
	8		Not connected

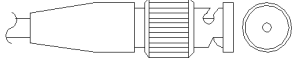
**Agilent 1100 to 3394/6 Integrators**

**Table 46**

Connector <b>35900-60750</b>	Pin <b>3394/6</b>	Pin <b>Agilent 1100</b>	Signal Name
	1		Not connected
	2	Shield	Analog -
	3	Center	Analog +

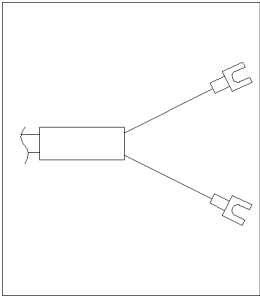
**Agilent 1100 to BNC Connector**

**Table 47**

Connector <b>8120-1840</b>	Pin <b>BNC</b>	Pin <b>Agilent 1100</b>	Signal Name
	Shield	Shield	Analog -
	Center	Center	Analog +

**Agilent 1100 to General Purpose**

**Table 48**

Connector <b>01046-60105</b>	Pin <b>3394/6</b>	Pin <b>Agilent 1100</b>	Signal Name
	1		Not connected
	2	Black	Analog -
	3	Red	Analog +

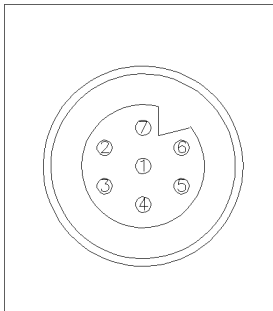
## Remote Cables



One end of these cables provides a Agilent Technologies APG (Analytical Products Group) remote connector to be connected to Agilent 1100 Series modules. The other end depends on the instrument to be connected to.

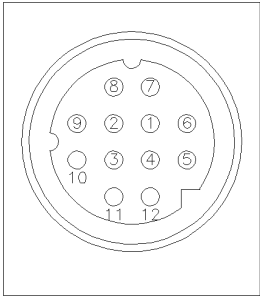
### Agilent 1100 to 3390 Integrators

Table 49

Connector <b>01046-60203</b>	Pin <b>3390</b>	Pin <b>Agilent 1100</b>	Signal Name	Active (TTL)
	2	1 - White	Digital ground	
	NC	2 - Brown	Prepare run	Low
	7	3 - Gray	Start	Low
	NC	4 - Blue	Shut down	Low
	NC	5 - Pink	Not connected	
	NC	6 - Yellow	Power on	High
	NC	7 - Red	Ready	High
	NC	8 - Green	Stop	Low
	NC	9 - Black	Start request	Low

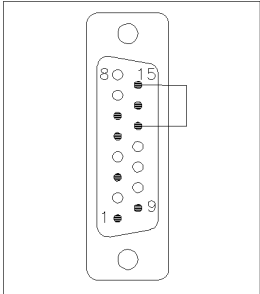
### Agilent 1100 to 3392/3 Integrators

Table 50

Connector 01046-60206	Pin 3392/3	Pin Agilent 1100	Signal Name	Active (TTL)
 <p>4 - Key</p>	3	1 - White	Digital ground	
	NC	2 - Brown	Prepare run	Low
	11	3 - Gray	Start	Low
	NC	4 - Blue	Shut down	Low
	NC	5 - Pink	Not connected	
	NC	6 - Yellow	Power on	High
	9	7 - Red	Ready	High
	1	8 - Green	Stop	Low
	NC	9 - Black	Start request	Low

### Agilent 1100 to 3394 Integrators

Table 51

Connector 01046-60210	Pin 3394	Pin Agilent 1100	Signal Name	Active (TTL)
	9	1 - White	Digital ground	
	NC	2 - Brown	Prepare run	Low
	3	3 - Gray	Start	Low
	NC	4 - Blue	Shut down	Low
	NC	5 - Pink	Not connected	
	NC	6 - Yellow	Power on	High
	5,14	7 - Red	Ready	High
	6	8 - Green	Stop	Low
	1	9 - Black	Start request	Low



**Table 51**

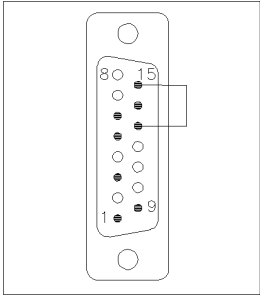
Connector <b>01046-60210</b>	Pin <b>3394</b>	Pin <b>Agilent 1100</b>	Signal Name	Active (TTL)
	13, 15		Not connected	

**NOTE**

START and STOP are connected via diodes to pin 3 of the 3394 connector.

**Agilent 1100 to 3396A Integrators**

**Table 52**

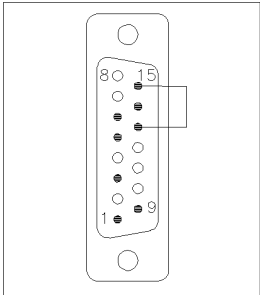
Connector <b>03394-60600</b>	Pin <b>3394</b>	Pin <b>Agilent 1100</b>	Signal Name	Active (TTL)
	9	1 - White	Digital ground	
	NC	2 - Brown	Prepare run	Low
	3	3 - Gray	Start	Low
	NC	4 - Blue	Shut down	Low
	NC	5 - Pink	Not connected	
	NC	6 - Yellow	Power on	High
	5,14	7 - Red	Ready	High
	1	8 - Green	Stop	Low
	NC	9 - Black	Start request	Low
	13, 15		Not connected	

**Agilent 1100 to 3396 Series II / 3395A Integrators**

Use the cable **03394-60600** and cut pin #5 on the integrator side. Otherwise the integrator prints START; not ready.

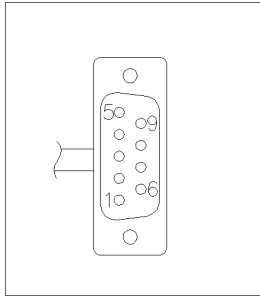
**Agilent 1100 to 3396 Series III / 3395B Integrators**

**Table 53**

Connector <b>03396-61010</b>	Pin <b>33XX</b>	Pin <b>Agilent 1100</b>	Signal Name	Active (TTL)
	9	1 - White	Digital ground	
	NC	2 - Brown	Prepare run	Low
	3	3 - Gray	Start	Low
	NC	4 - Blue	Shut down	Low
	NC	5 - Pink	Not connected	
	NC	6 - Yellow	Power on	High
	14	7 - Red	Ready	High
	4	8 - Green	Stop	Low
	NC	9 - Black	Start request	Low
	13, 15		Not connected	

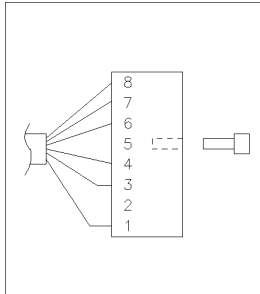
**Agilent 1100 to HP 1050, HP 1046A or Agilent 35900 A/D Converters**

**Table 54**

Connector <b>5061-3378</b>	Pin HP 1050/....	Pin Agilent 1100	Signal Name	Active (TTL)
	1 - White	1 - White	Digital ground	
	2 - Brown	2 - Brown	Prepare run	Low
	3 - Gray	3 - Gray	Start	Low
	4 - Blue	4 - Blue	Shut down	Low
	5 - Pink	5 - Pink	Not connected	
	6 - Yellow	6 - Yellow	Power on	High
	7 - Red	7 - Red	Ready	High
	8 - Green	8 - Green	Stop	Low
	9 - Black	9 - Black	Start request	Low

**Agilent 1100 to HP 1090 LC, HP 1040 DAD or Signal Distribution Module**

**Table 55**

Connector <b>01046-60202</b>	Pin HP 1090	Pin Agilent 1100	Signal Name	Active (TTL)
 <p>5 - Key</p>	1	1 - White	Digital ground	
	NC	2 - Brown	Prepare run	Low
	4	3 - Gray	Start	Low
	7	4 - Blue	Shut down	Low
	8	5 - Pink	Not connected	
	NC	6 - Yellow	Power on	High
	3	7 - Red	Ready	High
	6	8 - Green	Stop	Low
	NC	9 - Black	Start request	Low

Agilent 1100 to General Purpose

Table 56

Connector 01046-60201	Pin Universal	Pin Agilent 1100	Signal Name	Active (TTL)
		1 - White	Digital ground	
		2 - Brown	Prepare run	Low
		3 - Gray	Start	Low
		4 - Blue	Shut down	Low
		5 - Pink	Not connected	
		6 - Yellow	Power on	High
		7 - Red	Ready	High
		8 - Green	Stop	Low
		9 - Black	Start request	Low

## BCD Cables



One end of these cables provides a 15-pin BCD connector to be connected to the Agilent 1100 Series modules. The other end depends on the instrument to be connected to.

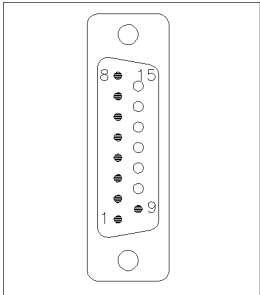
### Agilent 1100 to 3392/3 Integrators

Table 57

Connector <b>18584-60510</b>	Pin <b>3392/3</b>	Pin <b>Agilent 1100</b>	Signal Name	BCD Digit
<p>6 - Key</p>	10	1	BCD 5	20
	11	2	BCD 7	80
	3	3	BCD 6	40
	9	4	BCD 4	10
	7	5	BCD 0\	1
	5	6	BCD 3	8
	12	7	BCD 2	4
	4	8	BCD 1	2
	1	9	Digital ground	
	2	15	+ 5 V	Low

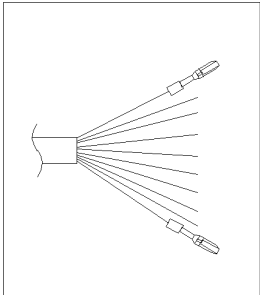
**Agilent 1100 to 3396 Integrators**

**Table 58**

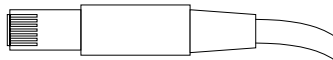
Connector 03396-60560	Pin 3392/3	Pin Agilent 1100	Signal Name	BCD Digit
	1	1	BCD 5	20
	2	2	BCD 7	80
	3	3	BCD 6	40
	4	4	BCD 4	10
	5	5	BCD 0\	1
	6	6	BCD 3	8
	7	7	BCD 2	4
	8	8	BCD 1	2
	9	9	Digital ground	
	NC	15	+ 5 V	Low

## Agilent 1100 to General Purpose

Table 59

Connector 18594-60520	Wire Color	Pin Agilent 1100	Signal Name	BCD Digit
	Green	1	BCD 5	20
	Violet	2	BCD 7	80
	Blue	3	BCD 6	40
	Yellow	4	BCD 4	10
	Black	5	BCD 0\	1
	Orange	6	BCD 3	8
	Red	7	BCD 2	4
	Brown	8	BCD 1	2
	Gray	9	Digital ground	
	White	15	+5 Vt	Low

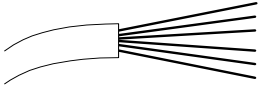
## Auxiliary Cable



One end of this cable provides a modular plug to be connected to the Agilent 1100 Series vacuum degasser. The other end is for general purpose.

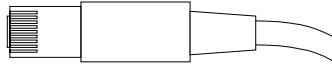
### Agilent 1100 Series Degasser to general purposes

Table 60

Connector <b>G1322-81600</b>	Color	Pin Agilent 1100	Signal Name
	White	1	Ground
	Brown	2	Pressure signal
	Green	3	
	Yellow	4	
	Grey	5	DC + 5 V IN
	Pink	6	Vent



## CAN Cable

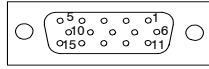


Both ends of this cable provide a modular plug to be connected to Agilent 1100 Series module's CAN-bus connectors.

**Table 61**

Agilent 1100 module to module, 0.5m lg	<a href="#">5181-1516</a>
Agilent 1100 module to module, 1m lg	<a href="#">5181-1519</a>
Agilent 1100 module to control module	<a href="#">G1323-81600</a>

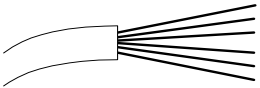
## External Contact Cable



One end of this cable provides a 15-pin plug to be connected to Agilent 1100 Series module's interface board. The other end is for general purpose.

### Agilent 1100 Series Interface Board to general purposes

Table 62

Connector <b>G1103-61611</b>	Color	Pin Agilent 1100	Signal Name
	White	1	EXT 1
	Brown	2	EXT 1
	Green	3	EXT 2
	Yellow	4	EXT 2
	Grey	5	EXT 3
	Pink	6	EXT 3
	Blue	7	EXT 4
	Red	8	EXT 4
	Black	9	Not connected
	Violet	10	Not connected
	Grey/pink	11	Not connected
	Red/blue	12	Not connected
	White/green	13	Not connected
	Brown/green	14	Not connected
	White/yellow	15	Not connected

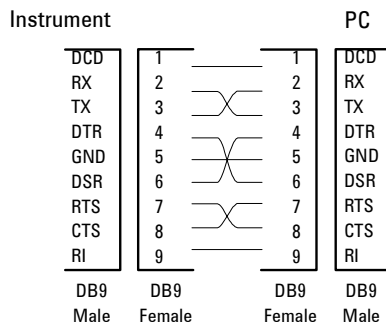
## RS-232 Cable Kit

This kit contains a 9-pin female to 9-pin female Null Modem (printer) cable and one adapter. Use the cable and adapter to connect Agilent Technologies instruments with 9-pin male RS-232 connectors to most PCs or printers.

### Agilent 1100 module to PC

#### RS-232 Cable Kit 34398A

**Table 63**

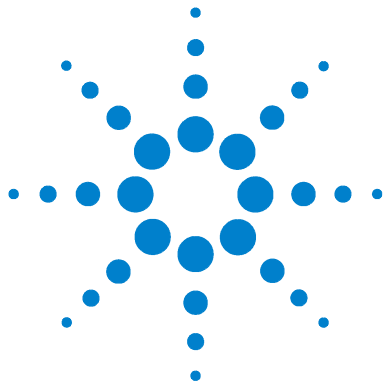


## LAN Cables

### Recommended Cables

For point to point connection (not using a network hub) use a twisted pair cross over LAN cable (P/N [5183-4649](#), 10 feet long).

For standard network connections using a hub use category 5 UTP cables, (P/N [G1530-61480](#), 8 m long).



## 6 Introduction to the Autosampler

Introduction to the Autosampler	214
Sampling Sequence	216
Sampling Unit	219
Transport Assembly	222
Early Maintenance Feedback (EMF)	224
Electrical Connections	226



## Introduction to the Autosampler

Five models of Agilent 1100 Series autosamplers are available; within this introduction they will be referred to as the standard, the micro, the preparative autosamplers and the thermostatted autosamplers. Unless otherwise stated all information in this section is valid for all models.

The Agilent 1100 Series autosamplers and Agilent 1100 Series thermostatted autosamplers are designed for use with other modules of the Agilent 1100 Series LC system, with the HP 1050 Series, or with other LC systems if adequate remote control inputs and outputs are available. The autosamplers are controlled from the Agilent 1100 Series control module or from the Agilent ChemStation for LC.

Three sample-rack sizes are available for the autosamplers. The standard full-size rack holds  $100 \times 1.8$  ml vials, while the two half-size racks provide space for  $40 \times 1.8$  ml vials and  $15 \times 6$  ml vials respectively. Any two half-size racks trays can be installed in the autosamplers simultaneously. A specially designed sample-rack holding  $100 \times 1.8$  ml vials is available for use with the thermostatted autosamplers. The half-size racks trays are not designed for an optimal heat transfer when they are used with a thermostatted autosampler.

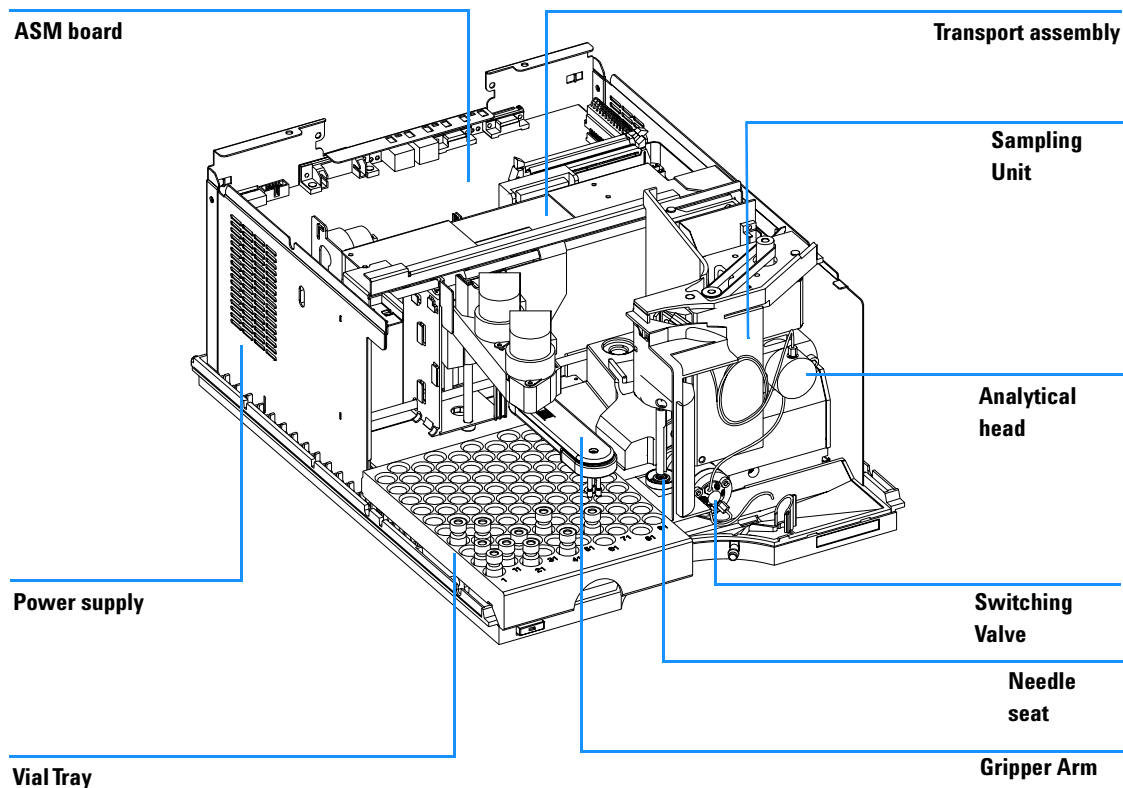
The autosamplers transport mechanism uses an X-Z-Theta movement to optimize vial pick-up and return. Vials are picked up by the gripper arm, and positioned below the sampling unit. The gripper transport mechanism and sampling unit are driven by motors. Movement is monitored by optical sensors and optical encoders to ensure correct operation. The metering device is always flushed after injection to ensure minimum carry-over.

The standard analytical head device provides injection volumes from  $0.1 - 100 \mu\text{l}$ . The micro analytical head device provides injection volumes from  $0.1 - 40 \mu\text{l}$ . Two preparative head devices provide injection volumes from  $0.1 - 900 \mu\text{l}$ . One head is limited by a system pressure of 200 bars, the other by a system pressure of 400 bars.

The six-port (only 5 ports are used) injection valve unit is driven by a high-speed hybrid stepper motor. During the sampling sequence, the valve unit bypasses the autosamplers, and connects flow from the pump to the column directly. During injection and analysis, the valve unit directs the flow through the autosamplers which ensures that all of the sample is injected onto the

column, and that the metering unit and needle are always free from sample residue before the next sampling sequence begins. Different valves for the standard, the micro and the preparative autosampler are available.

Control of the vial temperature in the thermostatted autosampler is achieved using an additional Agilent 1100 Series module; the ALS thermostat. Details of this module are given in the Agilent 1100 Series thermostatted autosampler Supplemental Manual.



**Figure 30** Overview of the Autosampler

## Sampling Sequence

The movements of the autosamplers components during the sampling sequence are monitored continuously by the autosamplers processor. The processor defines specific time windows and mechanical ranges for each movement. If a specific step of the sampling sequence is not completed successfully, an error message is generated.

Solvent is bypassed from the autosamplers by the injection valve during the sampling sequence. The sample vial is selected by a gripper arm from a static sample rack, or from external vial positions. The gripper arm places the sample vial below the injection needle. The required volume of sample is drawn into the sample loop by the metering device. Sample is applied to the column when the injection valve returns to the mainpass position at the end of the sampling sequence.

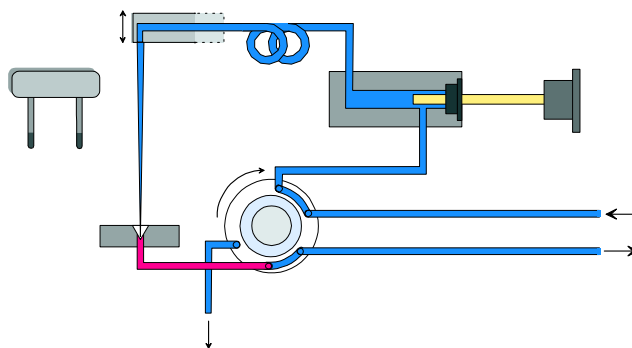
The sampling sequence occurs in the following order:

- 1 The injection valve switches to the bypass position.
- 2 The plunger of the metering device moves to the initialization position.
- 3 The gripper arm moves from the home position, and selects the vial. At the same time, the needle lifts out of the seat.
- 4 The gripper arm places the vial below the needle.
- 5 The needle lowers into the vial.
- 6 The metering device draws the preset sample volume.
- 7 The needle lifts out of the vial.
- 8 If the automated needle wash is selected (see [“Using the Automated Needle Wash”](#) on page 43), the gripper arm replaces the sample vial, positions the wash vial below the needle, lowers the needle into the vial, then lifts the needle out of the wash vial.
- 9 The gripper arm checks the safety flap is in position.
- 10 The gripper arm replaces the vial, and returns to the home position. Simultaneously, the needle lowers into the seat.
- 11 The injection valve switches to the mainpass position.



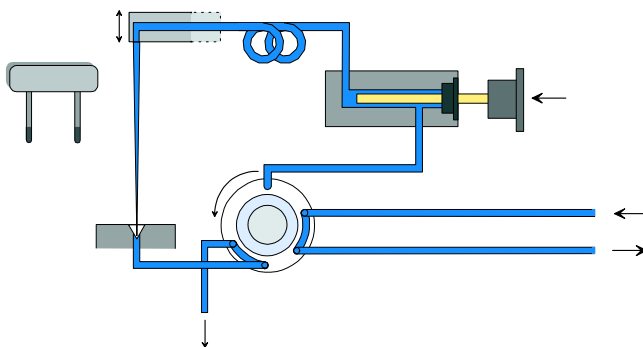
## Injection Sequence

Before the start of the injection sequence, and during an analysis, the injection valve is in the mainpass position (Figure 31). In this position, the mobile phase flows through the autosamplers metering device, sample loop, and needle, ensuring all parts in contact with sample are flushed during the run, thus minimizing carry-over



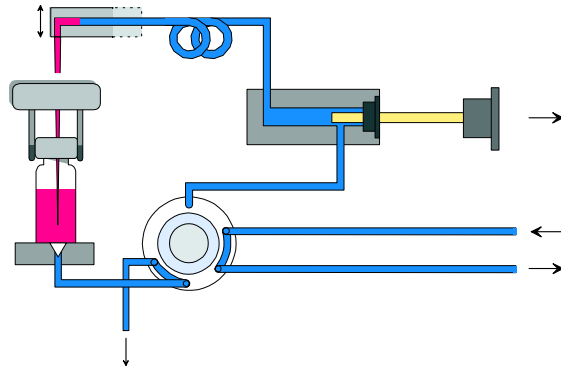
**Figure 31** Mainpass Position

When the sample sequence begins, the valve unit switches to the bypass position (Figure 32). Solvent from the pump enters the valve unit at port 1, and flows directly to the column through port 6.



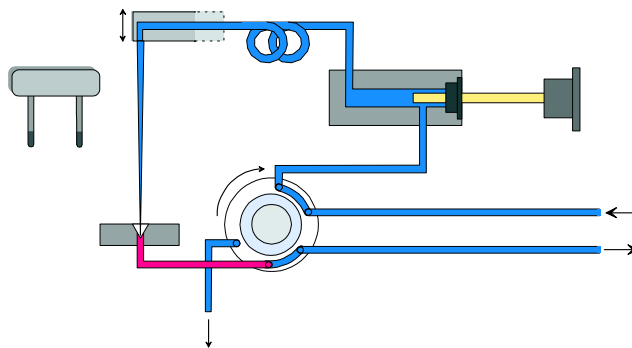
**Figure 32** Bypass Position

Next, the needle is raised, and the vial is positioned below the needle. The needle moves down into the vial, and the metering unit draws the sample into the sample loop (Figure 33).



**Figure 33** Drawing the Sample

When the metering unit has drawn the required volume of sample into the sample loop, the needle is raised, and the vial is replaced in the sample tray. The needle is lowered into the needle seat, and the injection valve switches back to the mainpass position, flushing the sample onto the column (Figure 34).



**Figure 34** Mainpass Position (Sample Injection)

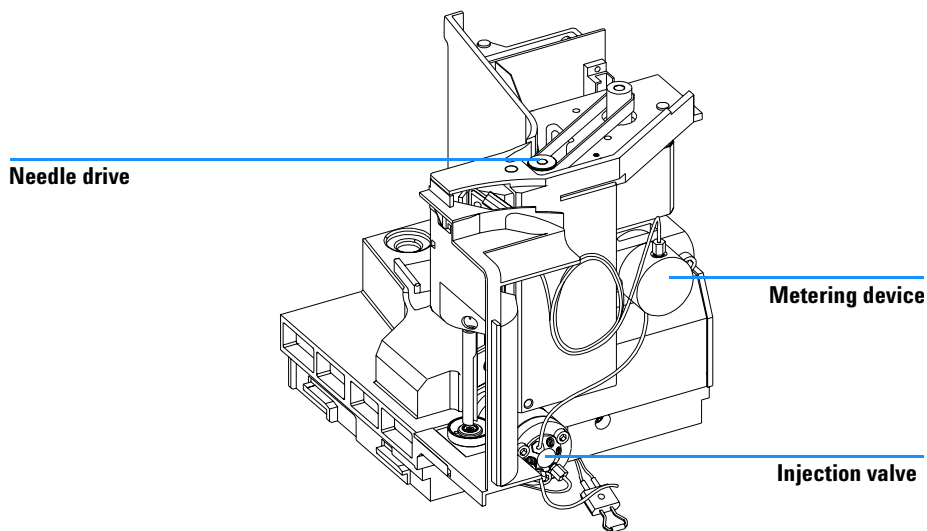
## Sampling Unit

The sampling unit comprises three main assemblies; needle drive, metering device, and injection valve.

**NOTE**

The replacement sampling unit *excludes* the injection valve and metering head assemblies.

The sampling units for the standard, the thermostatted, the micro and the preparative autosamplers are different.



**Figure 35** Autosampler Sampling Unit

## Needle-Drive

The needle movement is driven by a stepper motor connected to the spindle assembly by a toothed belt. The circular motion of the motor is converted to linear motion by the drive nut on the spindle assembly. The upper and lower needle positions are detected by reflection sensors on the sampling unit flex board, while the needle-in-vial position is determined by counting the motor steps from the upper needle-sensor position.

## Analytical head / preparative head

The analytical head is driven by the stepper motor connected to the drive shaft by a toothed belt. The drive nut on the spindle converts the circular movement of the spindle to linear motion. The drive nut pushes the sapphire plunger against the tension of the spring into the analytical head. The base of the plunger sits on the large bearing of the drive nut, which ensures the plunger is always centered. A ceramic ring guides the movement of the plunger in the analytical head. The home position of the plunger is sensed by an infra-red sensor on the sampling unit flex board, while the sample volume is determined by counting the number of steps from the home position. The backward movement of the plunger (driven by the spring) draws sample from the vial.

**Table 64** Analytical Head Technical Data

	Standard (100 µl)	Micro (40 µl)	Standard (900 µl)	Preparative (900 µl)
Number of steps	15000	60000	15000	15000
Volume resolution	7 nl/motor step	0.7 nl/motor step	60 nl/motor step	60 nl/motor step
Maximum stroke	100 µl	40 µl	900 µl	900 µl
Pressure limit	400 bars	400 bars	200 bars	400 bars
Plunger material	Sapphire	Sapphire	Sapphire	Sapphire

## Injection-Valve

The two-position 6-port injection valve is driven by a stepper motor. Only five of the six ports are used (port 3 is not used). A lever/slider mechanism transfers the movement of the stepper motor to the injection valve. Two microswitches monitor switching of the valve (bypass and mainpass end positions).

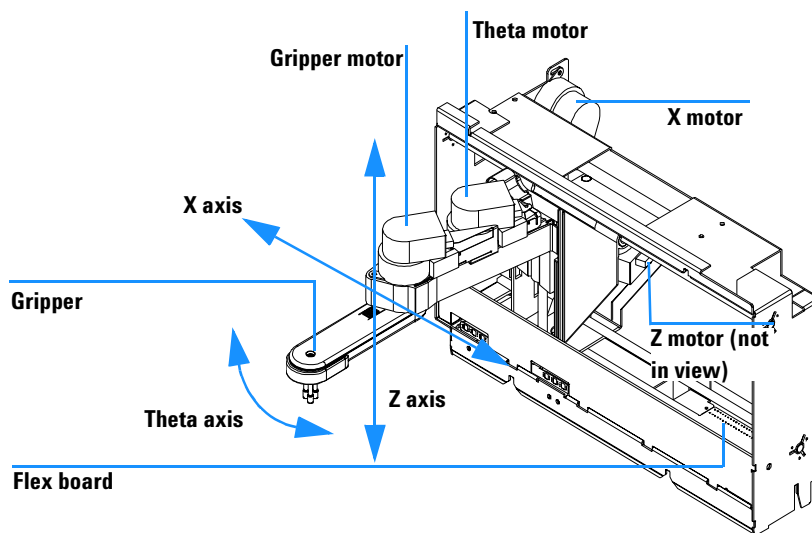
No valve adjustments are required after replacing internal components.

**Table 65** Injection-Valve Technical Data

	Standard	Micro	Preparative MBB™
Motor type	4V, 1.2A stepper motor	4V, 1.2A stepper motor	4V, 1.2A stepper motor
Seal material	VespeI™ (TefzeI™ available)	VespeI™	PEEK
Stator material	Ceramic/PEEK	Head coated SST	PEEK
Number of ports	6	6	6
Switching time	< 150 ms	< 150 ms	< 150 ms

## Transport Assembly

The transport unit comprises of an X-axis slide (left-right motion), a Z-axis arm (up-down motion), and a gripper assembly (rotation and vial-gripping).



**Figure 36** Transport Assembly

The transport assembly uses four stepper motors driven in closed-loop mode for accurate positioning of the gripper assembly for sample-vial transport. The rotational movement of the motors is converted to linear motion (X- and Z-axes) by toothed belts connected to the drive spindles. The rotation (theta axes) of the gripper assembly is transferred from the motor by a toothed belt and series of gears. The opening and closing of the gripper fingers are driven by a stepper motor linked by a toothed belt to the planetary gearing inside the gripper assembly.

The stepper motor positions are determined by the optical encoders mounted onto the stepper-motor housing. The encoders monitor the position of the motors continually, and correct for position errors automatically (e.g. if the gripper is accidentally moved out of position when loading vials into the vial tray). The initialization positions of the moving components are sensed by

reflection sensors mounted on the flex board. These positions are used by the processor to calculate the actual motor position. An additional six reflection sensors for tray recognition are mounted on the flex board at the front of the assembly.

## Early Maintenance Feedback (EMF)

Maintenance requires the exchange of components in the flow path which are subject to mechanical wear or stress. Ideally, the frequency at which components are exchanged should be based on the intensity of usage of the instrument and the analytical conditions, and not on a predefined time interval. The early maintenance feedback (EMF) feature monitors the usage of specific components in the instrument, and provides feedback when the user-setable limits have been exceeded. The visual feedback in the user interface provides an indication that maintenance procedures should be scheduled.

### EMF Counters

The autosamplers provides two EMF counters. Each counter increments with autosamplers use, and can be assigned a maximum limit which provides visual feedback in the user interface when the limit is exceeded. Each counter can be reset to zero after maintenance has been done. The autosamplers provides the following EMF counters:

#### **Injection valve counter**

This counter display the total number of switches of the injection valve since the last reset of the counter.

#### **Needle Movements Counter**

This counter displays the total number of movements of the needle into the seat since the last reset of the counter.



## Using the EMF Counters

The user-settable EMF limits for the EMF counters enable the early maintenance feedback to be adapted to specific user requirements. The wear of autosamplers components is dependent on the analytical conditions, therefore, the definition of the maximum limits need to be determined based on the specific operating conditions of the instrument.

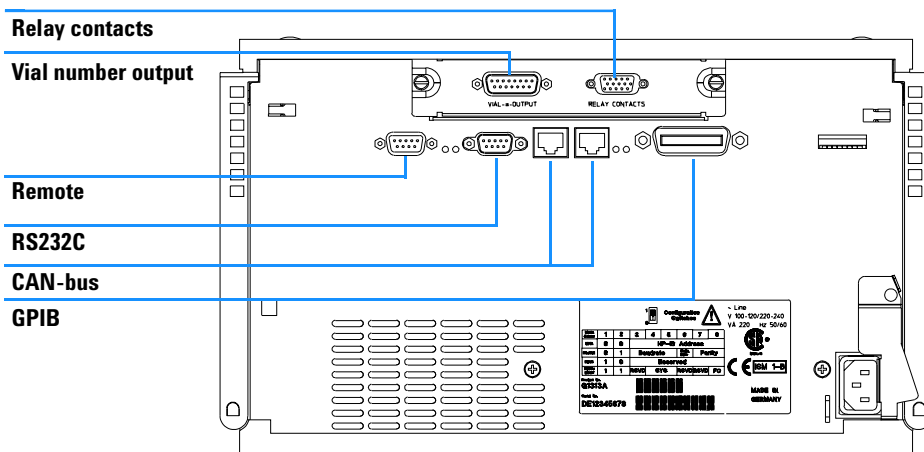
### Setting the EMF Limits

The setting of the EMF limits must be optimized over one or two maintenance cycles. Initially, no EMF limit should be set. When instrument performance indicates maintenance is necessary, make note of the values displayed by the injection valve and needle movements counters. Enter these values (or values slightly less than the displayed values) as EMF limits, and then reset the EMF counters to zero. The next time the EMF counters exceed the new EMF limits, the EMF flag will be displayed, providing a reminder that maintenance needs to be scheduled.

## Electrical Connections

**WARNING**

Never use cables other than the ones supplied by Agilent Technologies to ensure proper functionality and compliance with safety or EMC regulations.



**Figure 37** Autosampler Electrical Connections

- The GPIB connector is used to connect the autosamplers with a computer. The address and control switch module next to the GPIB connector determines the GPIB address of your autosamplers. The switches are preset to a default address (see [Table 72](#) on page 242) which is recognized once after power on.
- The CAN bus is a serial bus with high-speed data transfer. The two connectors for the CAN bus are used for internal Agilent 1100 Series module data transfer and synchronization.
- The REMOTE connector may be used in combination with other analytical instruments from Agilent Technologies if you want to use features such as common shut down, prepare, and so on.

- The RS-232 connector may be used to control the autosamplers from a computer through an RS-232 connection, using appropriate software. This connector needs to be activated by the configuration switch module next to the GPIB connector. The software needs the appropriate drivers to support this communication. See your software documentation for further information.
- The Thermostat-Autosampler connection (only on thermostatted autosampler) is used for control signal transfer and synchronization of the two modules. The cable must be installed for operation of the ALS thermostat.

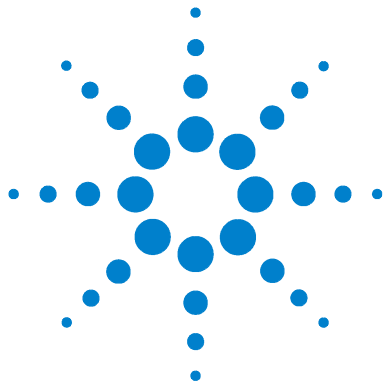
**WARNING**

**DO NOT disconnect or reconnect the autosampler to ALS thermostat cable when the power cords are connected to either of the two modules. This will damage the electronics of the modules.**

---

- The power input socket accepts a line voltage of 100–120 or 220–240 volts AC  $\pm 10\%$  with a line frequency of 50 or 60 Hz. There is no voltage selector on your autosamplers because the power supply has wide-ranging capability. There are no externally accessible fuses, because automatic electronic fuses are implemented in the power supply. The security lever at the power input socket prevents that the autosamplers cover is taken off when line power is still connected.
- The interface board slot is used for external contacts, BCD output and for future use.

## **6 Introduction to the Autosampler**



## 7 Theory of Operation

Autosampler Control and Electronics 230

Position and Movement Sensors 231

Autosampler Main Board (ASM) 232

Firmware Description 237

Optional Interface Boards 239

Interfaces 241

Setting the 8-bit Configuration Switch 246

The Main Power Supply Assembly 251



### **Autosampler Control and Electronics**

The ASM board controls the vial-transport mechanism, sampling needle, metering unit, and high-speed injection valve. These devices are controlled by a versatile electronics design based upon a 68000 family processor which also contains battery backup RAM, flash ROM, a real time clock, and several communications options.

## Position and Movement Sensors

Position sensing of movement of autosampler components is done by sensors on the sample transport and sampling unit flex boards. The following sensors are used:

**Table 66** Sample Transport Flex Board

Sensor Type	Number of Sensors	Position/Movement Sensed
Reflection Sensor	6	Vial tray identification
Reflection Sensor	1	Gripper initialization
Reflection Sensor	3	Transport assembly Initialization

**Table 67** Sampling Unit Flex Board

Sensor Type	Number of Sensors	Position/Movement Sensed
IR light sensor	1	Metering device home (reference) position
Reflection sensor	2	Needle end positions
Hall sensor	2	Front cover in position
Microswitch	2	Valve switching

## Autosampler Main Board (ASM)

### Common Electronics

A common electronics and firmware design is used for all Agilent 1100 Series LC modules. This core design provides a basic set of functions to each module.

**Table 68** Common Electronics

Core-processor	MC68332
Core-memory	The core unit has 3 memory blocks: 128k *16 bit PSRAM 1M*8 Flash memory 32k*8 NVRAM 24*8 serial NVRAM from the real time clock
Communication Interfaces	The core unit supports direct the following interfaces: CAN bus GPIB RS232 Remote MIO

### ASIC — Application- Specific Inte- grated Circuit

The application-specific integrated circuit (ASIC) provides interfacing to external devices through drivers, including GPIB, CAN, APG Remote. It is directly connected to the four control LEDs located near the connectors on this board and the 8-bit configuration switch which is used to configure the address for the GPIB communication, baud rate for RS-232 transfer, and so on. Also, the ASIC controls and drives module specific functions and reads static status signals.

### Leak Converter

Solvent leaking from the autosampler cools down the PTC. This changes the resistance of the PTC causing the leak converter to generate a leak signal. The leak converter consists of a PTC (for leak sensing) and an NTC (for ambient-temperature compensation). This configuration ensures ambient temperature changes do not affect the leak-sensing circuit.



- Fan Drive** The fan speed (two speeds are possible) is controlled by the main processor according to the internal heat distribution inside the module. The fan provides a PWM signal which is proportional to the revolution. This fan status signal is used for diagnostics.
- Electronic Fuses** The circuits that are connected to + 36 V are fused on the board electronically.
- Onboard Battery** An onboard lithium battery buffers the electronic memories when the module is turned off. For safety information on lithium batteries see "[Lithium Batteries Information](#)" on page 289.

### **Autosampler-Specific Electronics**

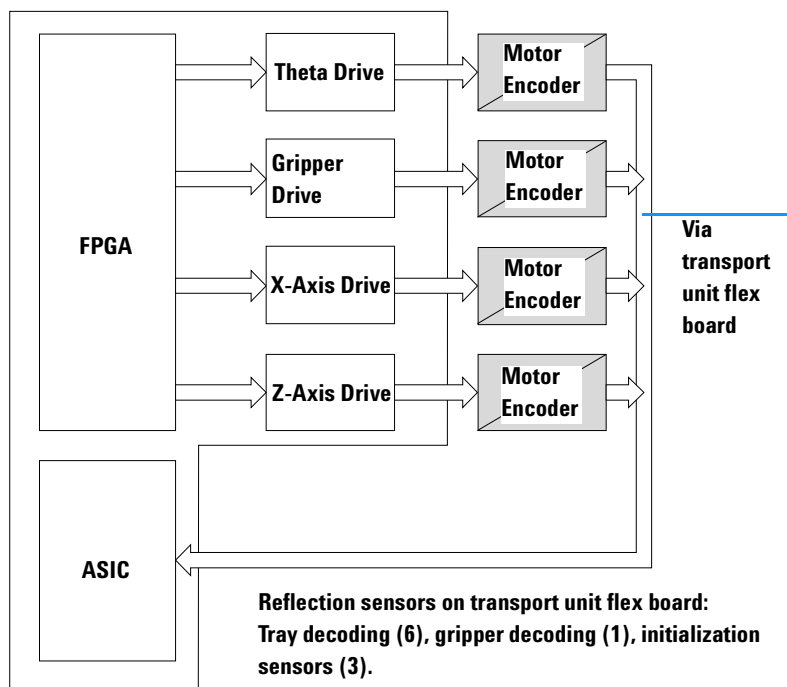
The autosampler specific functions provided by the electronics are:

- closed loop control of four axis vial handling servos
- electric valve control
- Needle unit control
- metering device control

### Transport Unit Control

The transport drive electronics use current-controlled pulse-width modulation (PWM) to drive the X, Z,  $\theta$ , and gripper motors in closed-loop servo control mode. Dedicated electronics in the SGS L6506 provide the current-control loop. Commutation is done in FPGA logic. SGS L6201 SMT output drivers are used for all four stepper motors. Motor encoder signals are connected to the ASIC where the encoder quadrature decoded clock and the up/down signal are used in the FPGA to provide instantaneous stepper motor commutation with respect to the motor rotor position.

Wiring between the autosampler main board (ASM) and the motors and encoders uses a flat-band cable (64 pin) and a flex board on which 10 reflection light sensors are located. Six light sensors are used for vial-tray identification, one for gripper decoding, and three for decoding of the initialization position.

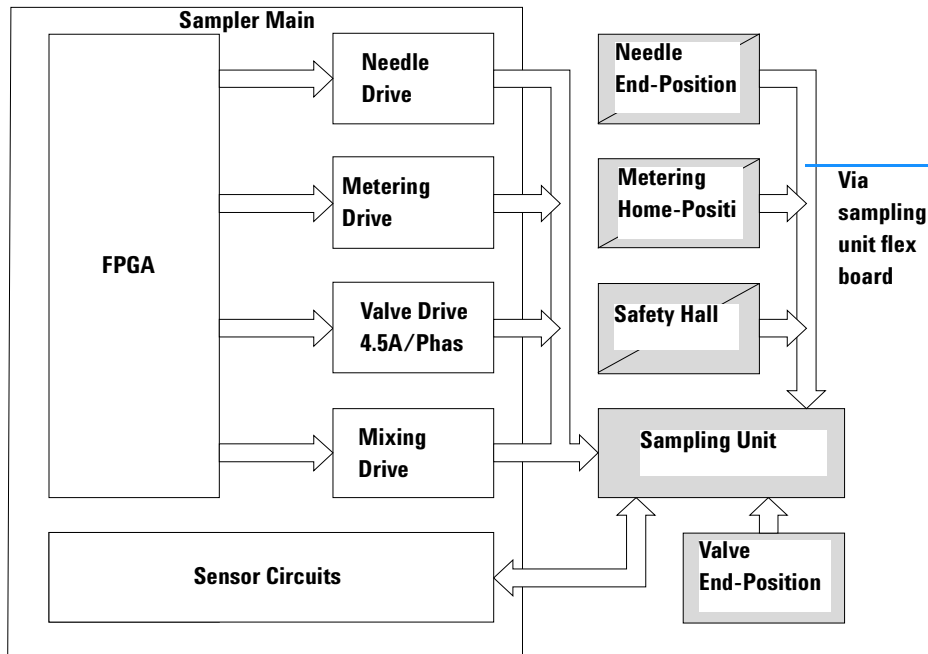


**Figure 38** Transport unit control

## Sampling Unit Control

Needle arm, metering device and valve motors are driven by controlled pulse-width modulation in the same way as the SGS L6506 (see “[Transport Unit Control](#)” on page 234). The motors require fast speed but do not require precise position control. Therefore, a closed loop servo system is not required. Commutation is done in FPGA logic. The needle arm, metering device and valve motors use SGS L6203 output drivers to deliver the higher currents required for fast movement or high torque.

The movement sensing of the valve motor is done by two microswitches. Two reflection light sensors are used to detect the end positions of the needle arm. One photo sensor is required to detect the home position of the metering device. Two hall sensors detect correct closure of the door (needle arm movement is interrupted if the door is open). All the sensors are mounted on one flex board. The flex board and motors are connected to the sampling unit distribution board (SUD). The SUD board is connected to the autosampler main board (ASM) via a flat-band cable (64 pin).



**Figure 39** Sampling unit control

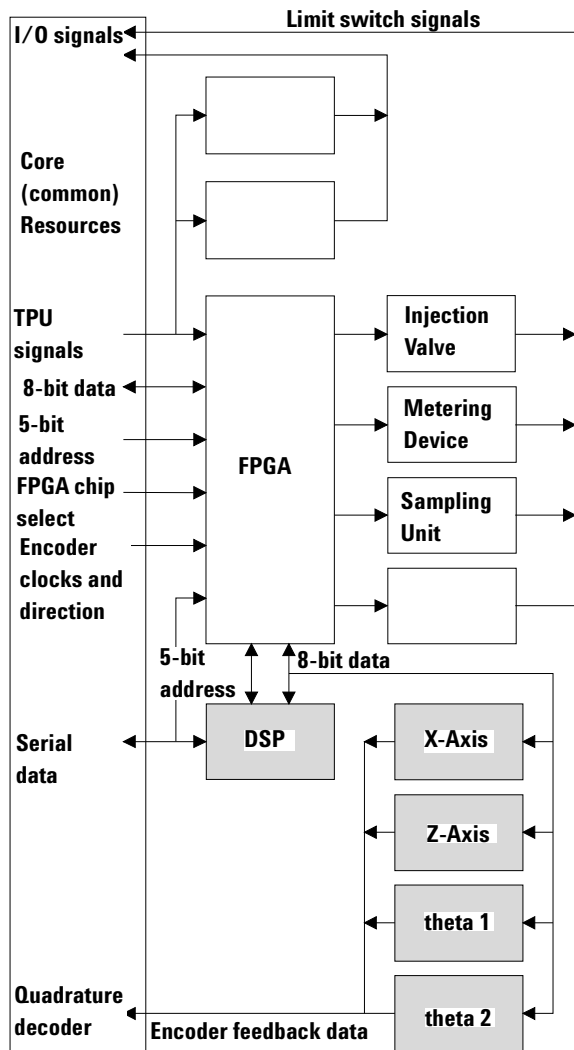


Figure 40 Autosampler block diagram

## Firmware Description

The firmware of the instrument consists of two independent sections:

- a non-instrument specific section, called 'resident system',
- an instrument specific section, called 'main system'.

### Resident System

This resident section of the firmware is identical for all Agilent 1100 series modules. Its properties are:

- the complete communication capabilities (GPIB, CAN, LAN and RS-232C),
- memory management,
- ability to update the firmware of the 'main system'.

### Main System

Its properties are:

- the complete communication capabilities (GPIB, CAN, LAN and RS-232C),
- memory management,
- ability to update the firmware of the 'resident system'.

In addition the main system comprises the instrument functions that are divided into common functions like

- run synchronization via APG remote
- error handling,
- diagnostic functions, and so on,

or module specific functions like

- internal events such as metering device, gripper and needle movements,

## Firmware Updates

Firmware updates can be done using your user interface:

- handheld control module with files from a PC-card or
- Agilent ChemStation with files from floppy disk

The file naming conventions are:

xxxx-vvv.DLB, where

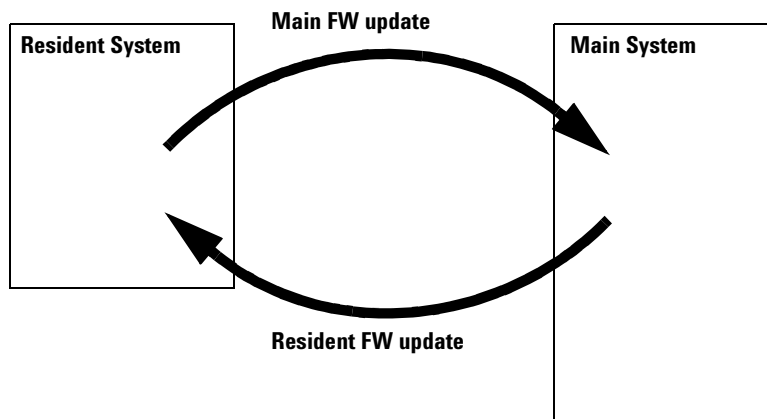
xxxx is the product number, e.g. 1313 for the G1313A Autosampler), and vvv is the revision number, for example 380 is revision 3.80

For instructions refer to your user interface.

### NOTE

Update of main system can be done in the resident system only.

Update of the resident system can be done in the main system only.



**Figure 41** Firmware Update Mechanism

## Optional Interface Boards

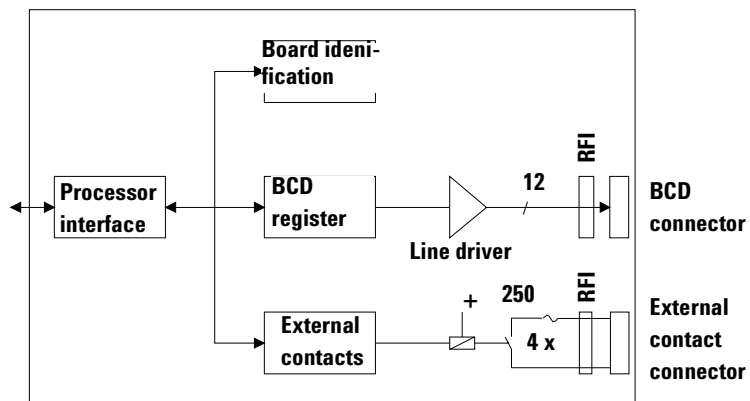
The Agilent 1100 Series modules have one optional board slot that allows addition of an interface board to the modules.

**Table 69** Optional Interface Boards

Description	Part Number
BCD Board	G1351-68701
Fuse 250 mA (four are on the board)	2110-0004
LAN Board (see next page for details)	

### BCD Board

The BCD board provides a BCD output for the bottle number of the Agilent 1100 Series autosampler and four external contacts. The external contact closure contacts are relay contacts. The maximum settings are: 30 V (AC/DC); 250 mA (fused). There are general purpose cables available to connect the BCD output, see “BCD Cables” on page 205 and the external outputs, see “External Contact Cable” on page 210 to external devices.



**Figure 42** Block Diagram BCD Board

### LAN Board

The HP JetDirect cards are network interface cards used in HP printers.

#### NOTE

One board is required per Agilent 1100 stack. It is recommended to add the LAN board to the detector with highest data rate.

#### NOTE

The LAN board can only be used together with:

- a main board version G13XX-66520 (DAD/MWD/VWD/Pump/ALS) or G13XX-66500 (FLD/RID) and above.
- a Agilent-ChemStation software revision A.06.01 or above.

The following cards can be used with the Agilent 1100 modules.

**Table 70** LAN Boards

Agilent Order Number	Supported networks
J4106A	Ethernet/802.3, RJ-45 (10Base-T)
J4105A	Token Ring/802.5, DB9, RJ-45 (10Base-T)
J4100A	Fast Ethernet, Ethernet/802.3, RJ-45 (10/100Base-TX) + BNC (10Base2)

#### NOTE

Minimum firmware of the JetDirect cards is A.05.05.

### Recommended Cables

For point to point connection (not using a network hub) use a twisted pair cross over LAN cable (P/N 5183-4649, 10 feet long).

For standard network connections using a hub use category 5 UTP cables, (P/N G1530-61480, 8 m long).



## Interfaces

The Agilent 1100 Series modules provide the following interfaces:

**Table 71** Agilent 1100 Series Interfaces

Interface Type	Pumps	Autosampler	DA Detector MW Detector FL Detector	VW Detector RI Detector	Thermostatted Column Compartment	Vacuum Degasser
CAN	Yes	Yes	Yes	Yes	Yes	No
GPIB	Yes	Yes	Yes	Yes	Yes	No
RS-232C	Yes	Yes	Yes	Yes	Yes	No
Remote	Yes	Yes	Yes	Yes	Yes	Yes
Analog	Yes	No	2 ×	1 ×	No	Yes*
Interface board	Yes	Yes	Yes	Yes	No	No

\* The vacuum degasser will have a special connector for specific use. For details see description of main board.

- CAN connectors as interface to other Agilent 1100 Series modules,
- GPIB connector as interface to the Agilent ChemStation,
- RS-232C as interface to a computer,
- REMOTE connector as interface to other Agilent products,
- Analog Output connector(s) for signal output, and
- Interface slot for specific interfacing (external contacts, BCD, LAN and so on).

For identification and location of the connectors [Figure 6](#) on page 27.

### WARNING

**Never use cables other than the ones supplied by Agilent Technologies to ensure proper functionality and compliance with safety or EMC regulations, see "External Tray G1313-60004" on page 193.**

## Analog Signal Output

The analog signal output can be distributed to a recording device. For details refer to the description of the module's main board.

## GPIB Interface

The GPIB connector is used to connect the module with a computer. The address and control switches next to the GPIB connector determine the GPIB address of your module. The switches are preset to a default address and recognized by the operating software from Agilent Technologies.

**Table 72** Default Addresses

Autosampler	28	Autosampler	28
Pump	22	RID	29
FLD	23		
VWD	24	Autosampler (HP 1050)	18
Agilent 8453A	25	Pump (HP 1050)	16
DAD / MWD	26	VWD (HP 1050)	10
Column Compartment	27	DAD (HP 1050)	17

## CAN Interface

The CAN is an intermodule communication interface. It is a 2-wire serial bus system supporting high speed data communication and real-time requirement.

## Remote Interface

The APG remote connector may be used in combination with other analytical instruments from Agilent Technologies if you want to use features such as common shut down, prepare, and so on.

Remote control allows easy connection between single instruments or systems to ensure coordinated analysis with simple coupling requirements.

The subminiature D connector is used. The module provides one remote connector which is inputs/outputs (wired-or technique).

To provide maximum safety within a distributed analysis system, one line is dedicated to SHUT DOWN the system's critical parts in case any module detects a serious problem. To detect whether all participating modules are switched on or properly powered, one line is defined to summarize the POWER ON state of all connected modules. Control of analysis is maintained by signal readiness READY for next analysis, followed by START of run and optional STOP of run triggered on the respective lines. In addition, PREPARE and START REQUEST may be issued. The signal level is defined as:

- standard TTL levels (0 V is logic true, + 5 V is false),
- fan-out is 10,
- input load is 2.2 kOhm against + 5 V, and
- outputs are open collector type, inputs/outputs (wired-or technique).

**Table 73** Remote Signal Distribution

Pin	Signal	Description
1	DGND	Digital ground
2	PREPARE	(L) Request to prepare for analysis (for example, calibration, detector lamp on). Receiver is any module performing pre-analysis activities.
3	START	(L) Request to start run / timetable. Receiver is any module performing run-time controlled activities.
4	SHUT DOWN	(L) System has serious problem (for example, leak: stops pump). Receiver is any module capable to reduce safety risk.
5		Not used
6	POWER ON	(H) All modules connected to system are switched on. Receiver is any module relying on operation of others.
7	READY	(H) System is ready for next analysis. Receiver is any sequence controller.

**Table 73** Remote Signal Distribution (continued)

Pin	Signal	Description
8	STOP	(L) Request to reach system ready state as soon as possible (for example, stop run, abort or finish and stop injection). Receiver is any module performing run-time controlled activities.
9	START REQUEST	(L) Request to start injection cycle (for example, by start key on any module). Receiver is the autosampler.

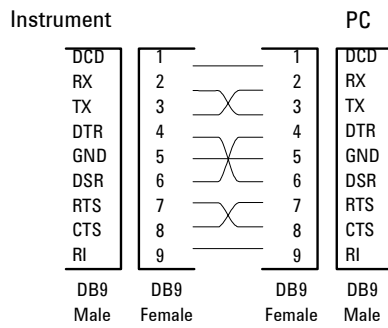
## RS-232C

The RS-232C connector is used to control the instrument from a computer through RS-232C connection, using the appropriate software. This connector can be activated by the configuration switch module next to the GPIB connector.

The RS-232C is designed as DCE (Data Communication Equipment) with a 9-pin male SUB-D type connector. The pins are defined as follows:

**Table 74** RS-232C Connection Table

Pin	Direction	Function
1	In	DCD
2	In	RxD
3	Out	TxD
4	Out	DTR
5		Ground
6	In	DSR
7	Out	RTS
8	In	CTS
9	In	RI

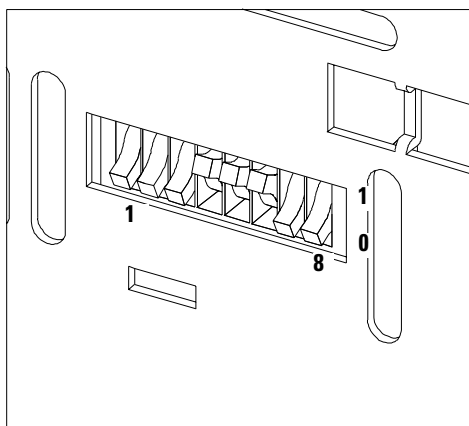


**Figure 43** RS-232 Cable

## Setting the 8-bit Configuration Switch

The 8-bit configuration switch is located next to the GPIB connector. Switch settings provide configuration parameters for GPIB address, serial communication protocol and instrument specific initialization procedures.

factory setting is shown for autosampler



**Figure 44** 8-bit Configuration Switch

**Table 75** 8-bit Configuration Switch

Mode Select	1	2	3	4	5	6	7	8
GPIB	0	0	GPIB Address					
RS-232C	0	1	Baudrate			Data Bits	Parity	
Reserved	1	0	Reserved					
TEST/BOOT	1	1	RSVD	SYS		RSVD	RSVD	FC

Switches 1 and 2 define which set of parameters (for example, for GPIB, RS-232C, and so on) will be changed. Once the change has been completed, the instrument must be powered up again in order to store the values in the non-volatile memory.

In the non-volatile memory the parameters are kept, regardless of whether you turn the instrument off and on again. They will be kept until the same set of parameters is subsequently changed and power is reset. All other previously stored configuration settings will still remain in the non-volatile memory.

In this way you can store more than one set of parameters using the same 8-bit configuration switch twice, for example, for both GPIB and RS-232C.

## GPIB Default Addresses

If you just want to change the GPIB address and need a detailed procedure, refer to the *Installing Your Agilent ChemStation System* handbook.

Default GPIB address is set to the following addresses:

**Table 76** Default Addresses for Agilent Series 1100 Modules

Module	Address	Binary Address
Pump	22	0 0 0 1 0 1 1 0
FLD	23	0 0 0 1 0 1 1 1
VWD	24	0 0 0 1 1 0 0 0
Agilent 8453A	25	0 0 0 1 1 1 0 1
DAD / MWD	26	0 0 0 1 1 0 1 0
Column compartment	27	0 0 0 1 1 0 1 1
Autosampler	28	0 0 0 1 1 1 0 0
RID	29	0 0 0 1 1 1 0 1

where 0 means that the switch is down and 1 means that the switch is up.

## Communication Settings for RS-232C Communication

The communication protocol used in this instrument supports only hardware handshake (CTS/RTS).

Switches 1 in down and 2 in up position define that the RS-232C parameters will be changed. Once the change has been completed, the instrument must be powered up again in order to store the values in the non-volatile memory.

**Table 77** Communication Settings for RS-232C Communication

Mode Select	1	2	3	4	5	6	7	8
RS-232C	0	1	Baud rate			Data Bits	Parity	

Use the following tables for selecting the setting which you want to use for RS-232C communication. The number 0 means that the switch is down and 1 means that the switch is up.

**Table 78** Baud Rate Settings

Switches			Baud Rate	Switches			Baud Rate
3	4	5		3	4	5	
0	0	0	9600	1	0	0	9600
0	0	1	1200	1	0	1	14400
0	1	0	2400	1	1	0	19200
0	1	1	4800	1	1	1	38400

**Table 79** Data Bit Settings

Switch 6	Data Word Size
0	7 Bit Communication
1	8 Bit Communication



**Table 80** Parity Settings

Switches		Parity
7	8	
0	0	No Parity
1	0	Odd Parity
1	1	Even Parity

One start bit and one stop bit are always used (not selectable).

Per default, the module will turn into 19200 baud, 8 data bit with no parity.

## Forced Cold Start Settings

Switches 1 and 2 do not force storage of this set of parameters in non-volatile memory. Returning switches 1 and 2 to other positions (other than being both up) will allow for normal operation.

### CAUTION

Forced cold start erases all methods and data stored in the non-volatile memory. Exceptions are diagnose and repair log books which will not be erased.

If you use the following switch settings and power the instrument up again, a forced cold start has been completed.

**Table 81** Forced Cold Start Settings

Mode Select	1	2	3	4	5	6	7	8
TEST/BOOT	1	1	0	0	0	0	0	1

To return to normal operation, set switches back to your GPIB or RS 232 configuration settings.

### Stay-Resident Settings

Firmware update procedures may require this mode in case of firmware loading errors.

Switches 1 and 2 do not force storage of this set of parameters in non-volatile memory. Returning switches 1 and 2 to other positions (other than being both up) will allow for normal operation.

If you use the following switch settings and power the instrument up again, the instrument firmware stays in the resident part, that is, it is not operable as a detector. It only uses basic functions of the operating system for example, for communication.

**Table 82** Stay Resident Settings

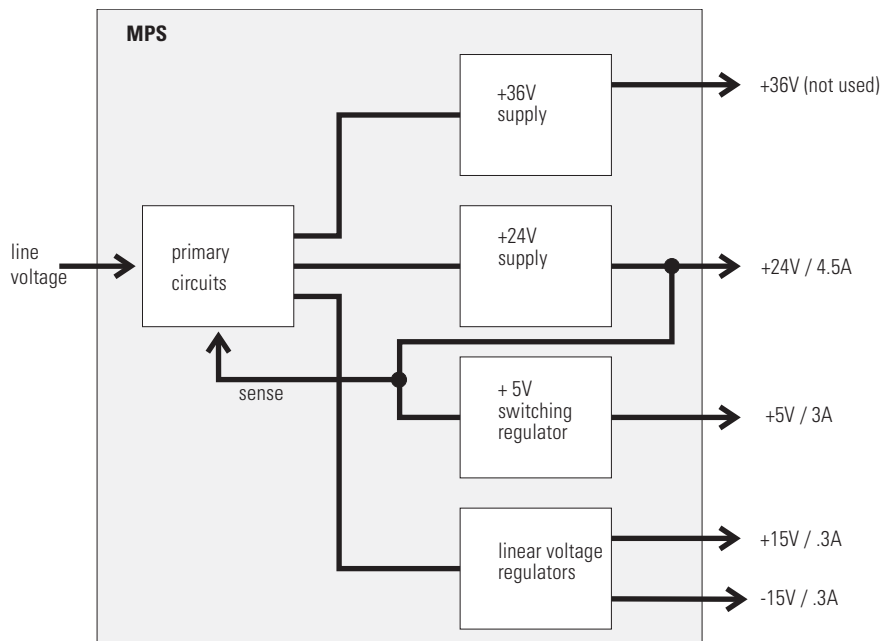
Mode Select	1	2	3	4	5	6	7	8
TEST/BOOT	1	1	0	0	1	0	0	0

To return to normal operation, set switches back to your GPIB or RS-232C configuration settings.

## The Main Power Supply Assembly

The main power supply comprises a closed assembly (no onsite repair possibility).

The power supply provides all DC voltages used in the module except for the voltages supplied by the lamp power supply to the deuterium and tungsten lamps in the detectors. The line voltage can vary in a range from 100 – 120 or 220 – 240 volts AC  $\pm 10\%$  and needs no manual setting.



**Figure 45** Main Power Supply (MPS) Blockdiagram

To disconnect the instrument from line, unplug the power cord. The power supply still uses some power, even if the power switch on the front panel is turned off.

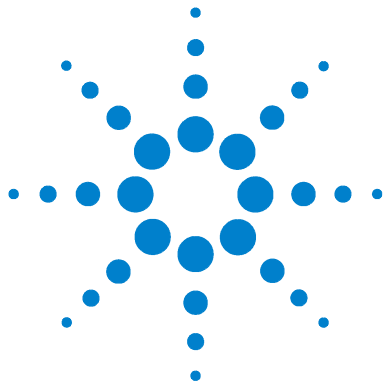
No accessible hardware fuse is needed because the main power supply is safe against any short circuits or overload conditions on the output lines. When overload conditions occur, the power supply turns off all output voltages. Turning the line power off and on again resets the power supply to normal operation if the cause of the overload condition has been removed.

An over-temperature sensor in the main power supply is used to turn off output voltages if the temperature exceeds the acceptable limit (for example, if the cooling fan of the instrument fails). To reset the main power supply to normal operating conditions, turn the instrument off, wait until it is approximately at ambient temperature and turn the instrument on again.

The following table gives the specifications of the main power supply.

**Table 83** Main Power Supply Specifications

Maximum power	130 W	Continuous output
Line Input	100 – 120 or 220 – 240 volts AC ± 10 %, line frequency of 50/60 Hz	Wide ranging
Output 1	+ 24 V / 4.5 A (maximum)	total power consumption of + 24 V and + 36 V must not exceed 107 W.
Output 2	+ 36 V / 2.5 A (maximum)	
Output 3	+ 5 V / 3 A	
Output 4	+ 15 V / 0.3 A	
Output 5	- 15 V / 0.3 A	



## 8 Introduction to the Control Module

Major keys on the Agilent 1100 Control Module [254](#)

Screens available from the Analysis screen [255](#)

Screens available from the System screen [266](#)

Screens available from the Records screen [269](#)

Diagnostics and Tests [274](#)



## Major keys on the Agilent 1100 Control Module

**Table 84**

<b>ESC</b>	Return to previous screen and scroll through top layer views (Analysis, Settings)
<b>m</b>	Open context sensitive menus
<b>i</b>	Information/help
<b>Enter</b>	Store changed parameters or execute the choice from a pull-down menu
<b>On/Off</b>	Switch on lamp(s)
<b>Start</b>	Start a run
<b>Plot</b>	View the chromatogram
<b>Views</b>	Change between view of analysis - status - system screens

**NOTE**

The screens shown on the next pages are based on:  
Control Module firmware revision B.01.01  
LC Module firmware revision 3.8x

**NOTE**

In case the control module's display seems to be frozen (hang-up due to a communication problem on the CAN bus), unplug the control module from the LC module and reconnect.

## Screens available from the Analysis screen

### The Analysis screen

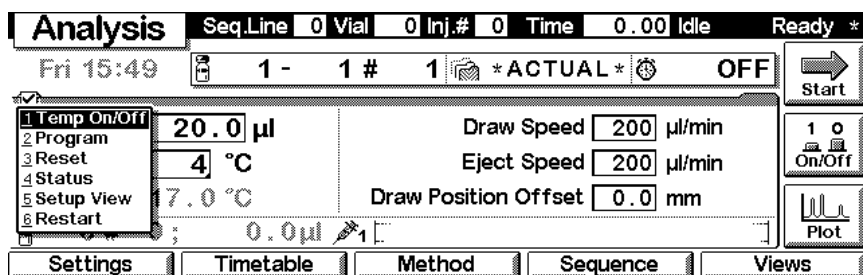
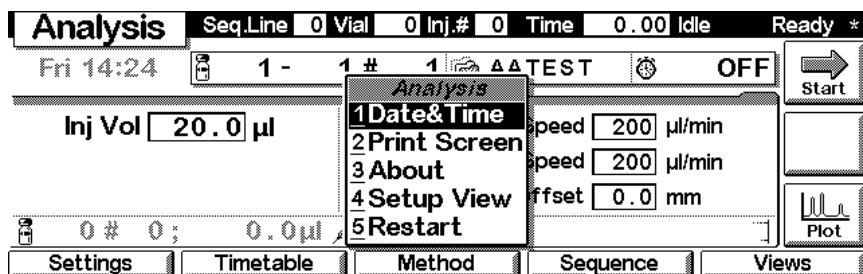
This is the wake-up screen, if the Agilent 1100 Series autosampler or thermostatted autosampler is the only configured Agilent 1100 module. It is used to enter the most common ALS method parameters.

Analysis		Seq.Line	0	Vial	0	Inj.#	0	Time	0.00	Idle	Ready *
Fri 14:23		1	-	1	#	1		AATEST		OFF	Start
Inj Vol		20.0		µl		Draw Speed		200		µl/min	
						Eject Speed		200		µl/min	
						Draw Position Offset		0.0		mm	
0 # 0;		0.0		µl						Plot	
Settings	Timetable	Method	Sequence	Views							

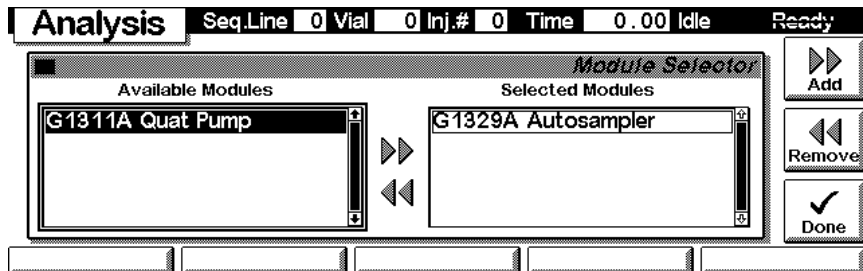
Analysis		Seq.Line	0	Vial	0	Inj.#	0	Time	0.00	Idle	Ready *
Fri 15:49		1	-	1	#	1		*ACTUAL*		OFF	Start
Inj Vol		20.0		µl		Draw Speed		200		µl/min	
Temp		4		°C		Eject Speed		200		µl/min	
				~ 17.5 °C		Draw Position Offset		0.0		mm	
0 # 0;		0.0		µl						Plot	
Settings	Timetable	Method	Sequence	Views							

## 8 Introduction to the Control Module

The **m**-key allows access to the context sensitive menu. **Setup view** leads you to add sections for additional Agilent 1100 modules. **Restart** re-boots the control module.

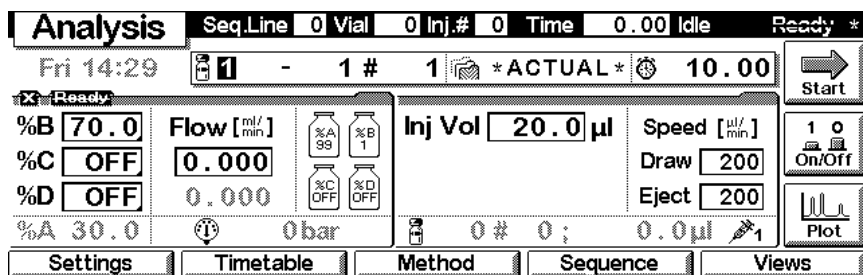


In the Setup view, e.g. the quaternary pump can be added to the view.

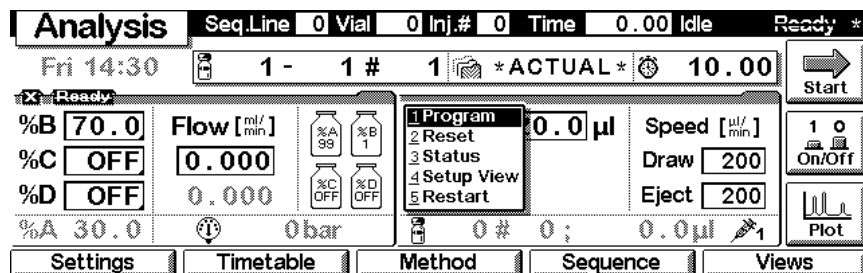




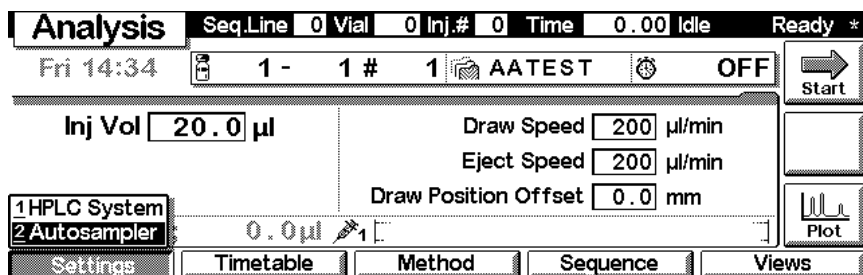
Here, e.g. the quaternary pump parameters are shown on the display as well. The number of parameters on the display are restricted as additional modules are added. A maximum of 4 modules are shown automatically. If more modules are in the system, you have to choose in Setup view. The number of parameters on the display are restricted as additional modules are added.



The **m**-key gives access to a context sensitive menu (e.g. when the cursor is positioned in the excitation window).

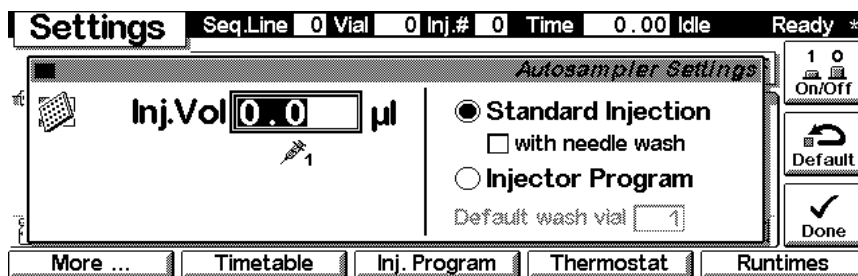
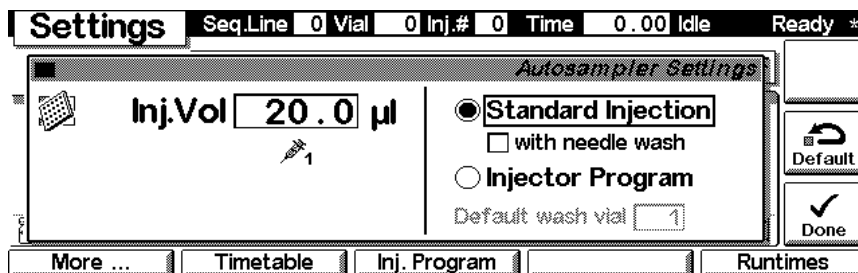


With the **Settings** key you open a pull-down menu where you can select the ALS module.

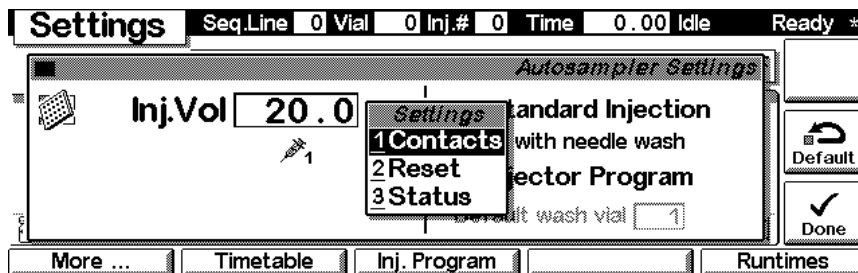


### Settings

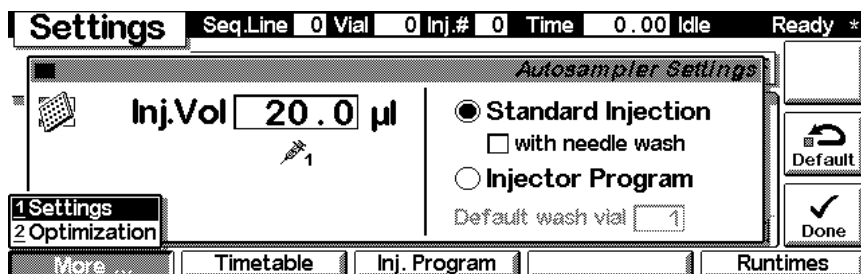
Within the **Settings** you can change the ALS parameters and with a different set of parameters available through the F1-5 keys. F7 key resets the ALS to default values. F8 opens a window to turn on the thermostat.



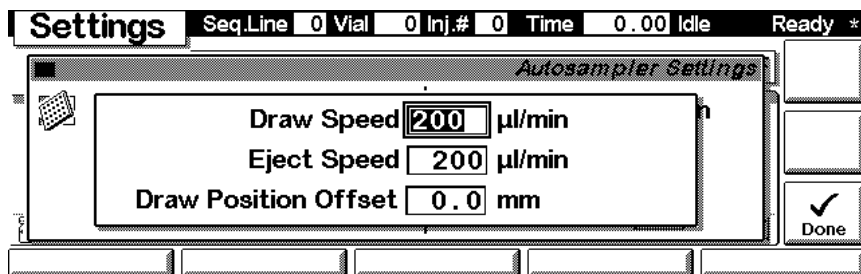
Use the **m**-key for the context sensitive menu. The **Status** command pulls up a monitor screen displaying details of injections and the sample tray. **Reset** will initialize the autosampler.



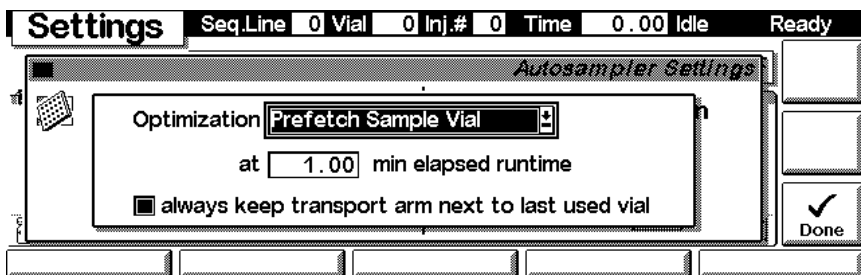
Use F1-key (**More**) opens a pull-down menu.



Selecting **More** and **Settings** pull down menu you can enter special ALS setpoints.

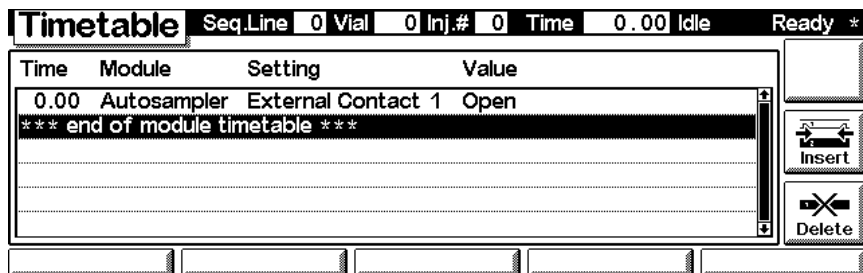


Selecting **More** and **Optimization** on the pull down menu you can enter different optimization modes.

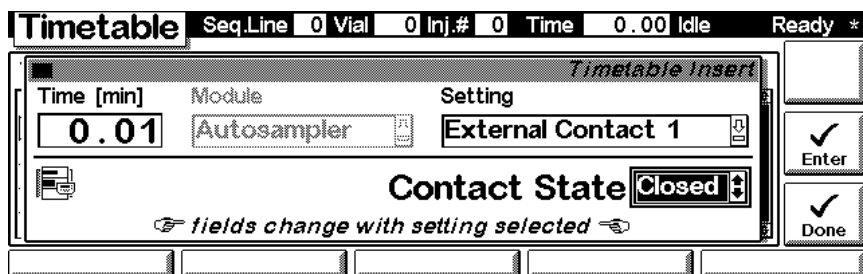


### Settings - Timetable

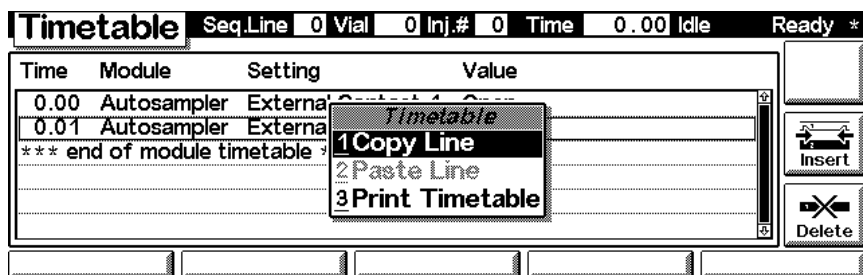
With the F2 key (**Timetable**) you can list the timetable for the ALS. Press F7 key (**Insert**) to add entries or F6 key (**Delete**) to remove entries.



Press the F7 key (**Insert**) to add timetable events. Use the F6 key (**Done**) to view the entered lines of the timetable.



Use the **m**-key for the context sensitive menu. It gives you additional tools for the timetable.



## Settings - Injection Program

With the F3 key (**Inj. Program**) you can change the settings for the analog outputs.

Program			Seq.Line	0	Vial	0	Inj.#	0	Time	0.00	Idle	Ready *
Line	Function	Parameters	press ENTER to edit line									
1	DRAW	2.0 µl from vial 1										
2	DRAW	2.0 µl from vial 2										
3	DRAW	2.0 µl from vial 3										
4	MIX	12.0 µl in air, 10 time(s)										
*** end of program ***												

Validate

Insert

Delete

Press the F7 key (**Insert**) to add program events. Use the F6 key (**Done**) to view the entered lines of the timetable.

Program			Seq.Line	0	Vial	0	Inj.#	0	Time	0.00	Idle	Ready *
Line Function			insert Line									
1	INJECT											

Enter

Done

Use the **m**-key for the context sensitive menu. It gives you additional tools for the timetable. The F8 key (**Validate**) will check the injector program for errors.

Program			Seq.Line	0	Vial	0	Inj.#	0	Time	0.00	Idle	Ready *
Line	Function	Parameters	press ENTER to edit line									
1	DRAW	2.0 µl from										
2	DRAW	2.0 µl from										
3	DRAW	2.0 µl from										
4	MIX	12.0 µl in a										
5	INJECT											
*** end of program ***												

Validate

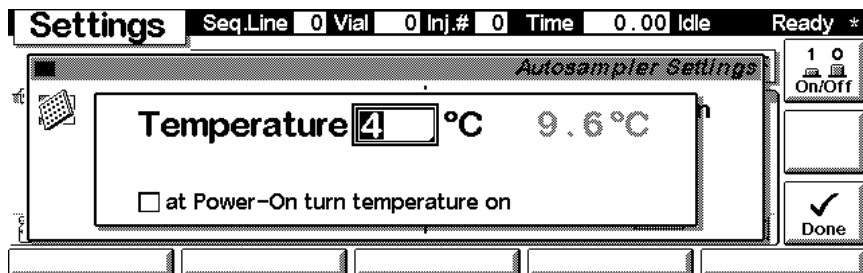
Insert

Delete

**Program**  
 1 Copy Line  
 2 Paste Line  
 3 Load Default  
 4 Print Program

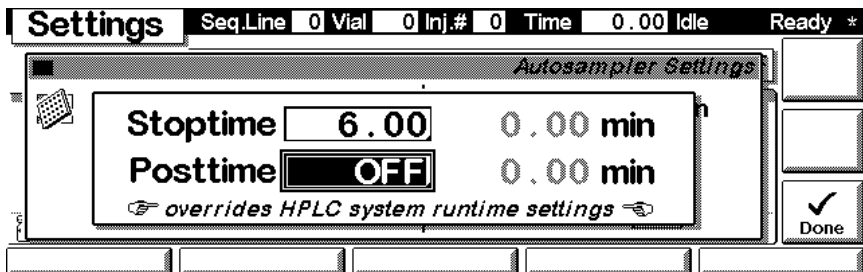
### Settings - Thermostat

With the F4 key (**Thermostat**) you can set the autosampler thermostat temperature.



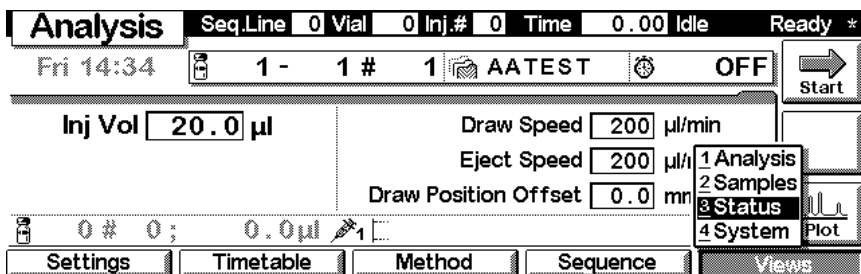
### Settings - Run times

With the F5 key (**Runtimes**) you can change the stop time and the post-run time.

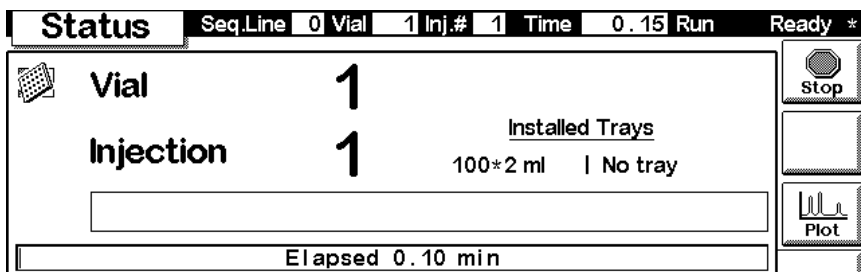


## Status

Press F5 key (**Views**) and select **Status**.

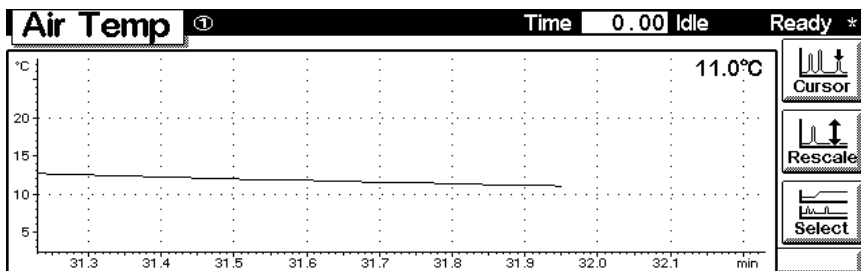


This is an example if an Agilent 1100 ALS is configured stand-alone.

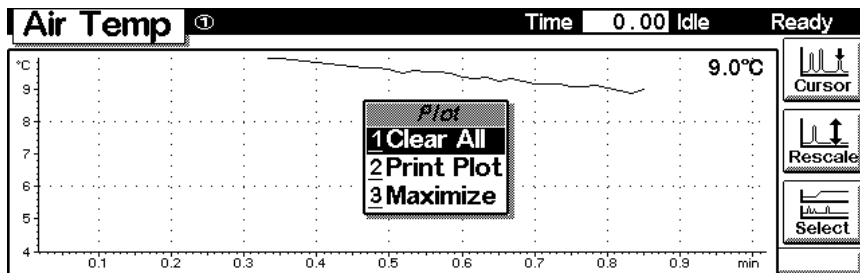


## Signal plot

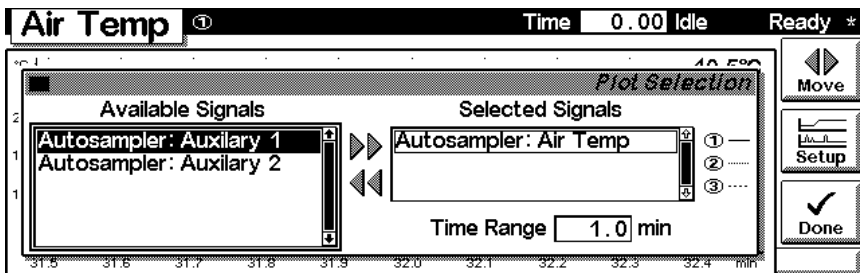
Press F6 key (**Plot**) to enter the plot screen (available also from the **Analysis** and **System** screen). Here you can observe the on-line signal(s). To add additional on-line signals (maximum 3), press F6 key (**Select**). If more than one signal is configured (see next), use the 1-2-3 number key to switch between the signals.



Press the **m**-key to open the context sensitive menu.



Press F6 key (**Select**). Here you can add additional on-line signals (maximum are 3). Additional signals could be also pressure or temperature signals from other modules. Use the Right/Left arrows to switch between Available and Selected Signals. Use the F8 key (**Move**) to enter available signals into the box for selected signals or vice versa.





## Method screens

Use ESC to return to the **Analysis** screen. Use the F3 key (**Method**) to view the parameters in a method and F8 key (**Save As**) to save the method in the module(s). The PC-Card key is only active when a PCMCIA card is inserted in the control module.

Method		Seq.Line	0	Vial	1	Inj.#	1	Time	0.00	Abort	Ready *
Setting	Value	AATEST									
Stoptime	OFF										
Posttime	OFF										
Injection Volume	20.00 µl										
Draw Speed	200 µl/min										
Eject Speed	200 µl/min										
Draw Position Offset	0.0 mm										
Module		PC-Card		Timetable							

Use F2 key (**PC-Card**) to save a method on a PCMCIA card. Use the Right/Left arrows to switch between PC-Card and Instrument window. Use the UP/Down arrows to select the method. Use the F7/F8 keys (**Copy**) to enter available signals into the box for selected signals or vice versa. Press the **m**-key to open the context sensitive menu.

Method		Seq.Line	0	Vial	1	Inj.#	1	Time	0.00	Abort	Ready
Methods on PC-Card		Methods on Instrument									
SDL0206 07/02/99 14:51		AATEST 03/10/99 11:38									
*** end of method list ***		*** end of method list ***									
Initialize											

Method		Seq.Line	0	Vial	1	Inj.#	1	Time	0.00	Abort	Ready
Methods on PC-Card		Methods on Instrument									
SDL0206 07/02/99 14:51		Method 03/10/99 11:38									
*** end of method list ***		method list ***									
		1 Print Directory									
		2 Restart									
Initialize											

## Screens available from the System screen

### System screen

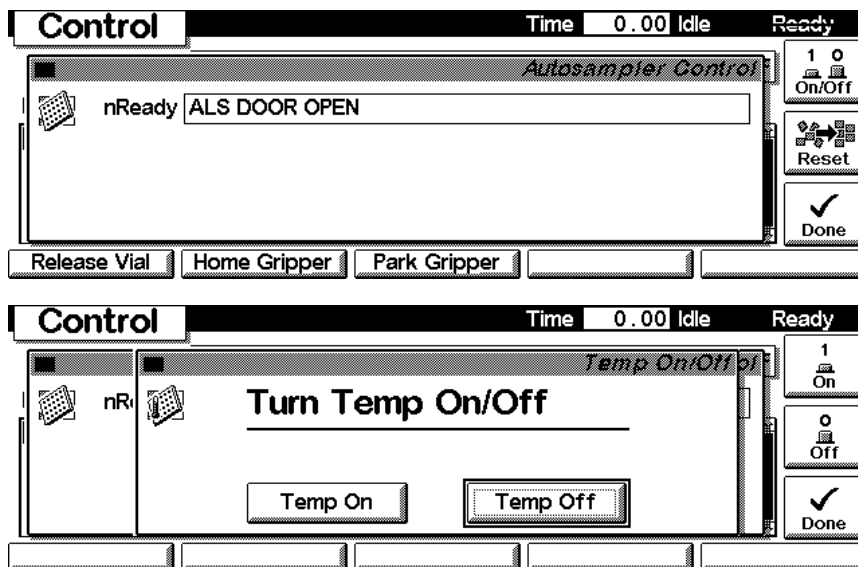
Use the Esc key to receive **Views** on the F5 key. Choose **System** from the pull-down menu. This screen shows the last activities in the system.

The screenshot shows the 'System' screen with the following layout:

- System** (Title bar)
- Time** 0.00 **Abort** **Ready**
- Fri 14:53** (Date/Time)
- EMF** (Label)
- Start** (Button with right arrow)
- Module** **Message** **Id** **Date** **Time** (Table Headers)
- |             |                       |       |       |          |
|-------------|-----------------------|-------|-------|----------|
| Autosampler | Door closed           | INFO  | 07/02 | 14:53:10 |
| Autosampler | Door opened           | INFO  | 07/02 | 14:53:04 |
| Autosampler | Module method deleted | INFO  | 07/02 | 14:51:49 |
| Autosampler | Module method saved   | INFO  | 07/02 | 14:51:22 |
| Controller  | No analysis           | STATE | 07/02 | 14:49:01 |
- Plot** (Button with graph icon)
- Control** **Configure** **Tests** **Records** **Views** (Navigation buttons)

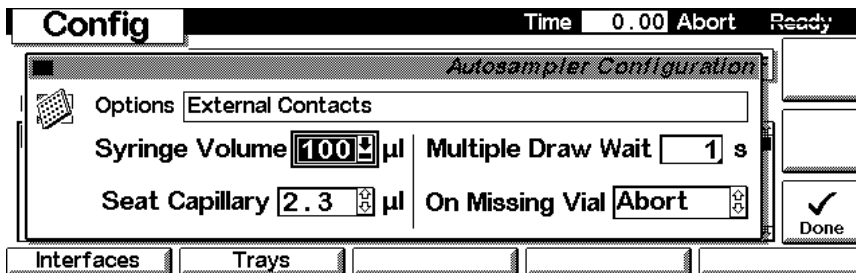
## System - Control

Use the F1 key (**Control**) to select the Autosampler. Here you receive information about the not-ready conditions if needed. F2 key (**Reset**) does a re-initialization of the ALS. Use the F8 key (**On/Off**) to turn on the thermostat. The F1 key (**Release Vial**) releases a vial held in the gripper, the F2 key (**Home Gripper**) returns the gripper to the home position and the F3 key (**Park Gripper**) parks the gripper in preparation for transport.

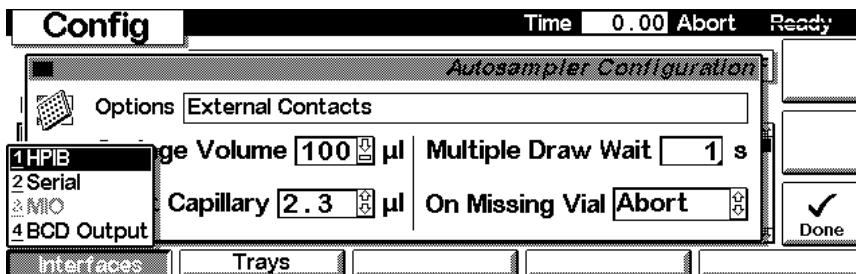


### System - Configuration

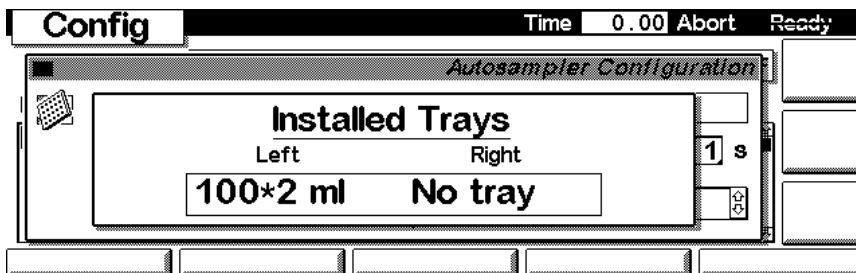
Use the **Esc** key to receive **Views** on the F5 key. Choose **System** from the pull-down menu. Use the F2 key (**Configure**) to select the ALS. Here you define further special setpoints for the ALS operation.



Use the F1 key (**Interfaces**) to access the interface settings (if required).



Use the F2 key (**Trays**) to view the detected sample trays.



## Screens available from the Records screen

### Records screen

Use the Esc key to receive **Views** on the F5 key. Choose **System** from the pull-down menu. Use the F4 key (**Records**) to select the ALS. Errors are reported either into the **System Log** (F2) or **Error Log** (F3).

Records						Time	0.00	Idle	Ready
Module	Product#	Serial#	Version	On-Time	EMF				
Controller	G1323B*	DE83100000	B.01.01	0d 00:07h		Identify			
Autosampler	G1329A*	DE12345678	A.03.80	0d 00:07h					
	G1330A	DE73300317				Print			

EMF   System Log   Error Log   Maint Log   FW Update

### System / Error Log

Use the F2 key (**System Log**) or F3 key (**Error Log**) to look for errors. For troubleshooting reasons they can be printed or saved to a file on the PCMCIA card (pressing the **m**-key).

Records		Time	0.00	Idle	Ready
<i>Autosampler System Logbook</i>					
Message	Date	Time			
Initialization done	07/02/99	15:19:43			
Thermostat off	07/02/99	15:18:44			
Thermostat at setpoint	07/02/99	15:18:44			
Initialization	07/02/99	15:18:44			
No analysis	07/02/99	15:18:44			
					Print

Records		Time	0.00	Idle	Ready
<i>Autosampler System Logbook</i>					
Message	Date	Time			
Initialization done	07/02/99	15:19:43			
Thermostat off	07/02/99	15:18:44			
Thermostat at setpoint	07/02/99	15:18:44			
Initialization	07/02/99	15:18:44			
No analysis	07/02/99	15:18:44			
Logbook 1 Save Logbook					Print

### Info Log

Use the **m**-key to receive a pop-up menu, Select **Info Log**. A list of the last events are listed. For troubleshooting reasons they can be printed or saved to a file on the PCMCIA card (pressing the **m**-key).

Records		Time	0.00	Idle	Ready
<i>Autosampler Info Logbook</i>					
Message	Date	Time			
Tray changed	07/02/99	15:18:38			
Info (0x00d9,10)	07/02/99	15:18:30			
External abort request	07/02/99	15:17:37			
On-Error action executed	07/02/99	15:17:14			
Door closed	07/02/99	15:16:46			
					Print

### EMF (Early Maintenance Feedback)

Use the F1 key (**EMF**) to set EMF parameters. Choose menu item 1 (**Setup limits**) to select the number of injection valve cycles or number of needle movements into the needle seat at which you want to receive a warning.

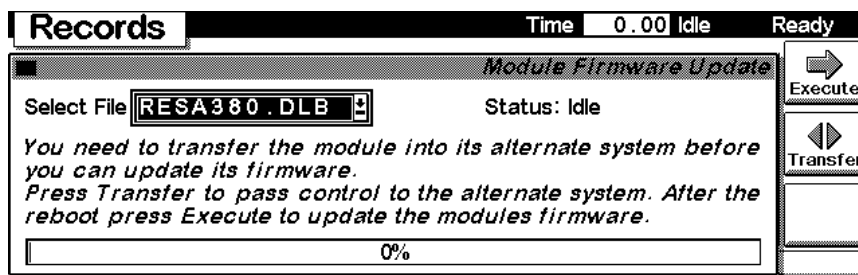
Records		Time	0.00	Idle	Ready
<i>Autosampler EMF Limits</i>					
G1329A Autosampler		Serial# DE12345678			
# Valve Cycles	34313	Limit	<input type="checkbox"/> OFF		
# Needle into Seat	34875	Limit	<input type="checkbox"/> OFF		
					<input type="checkbox"/>
					<input type="checkbox"/>
					<input checked="" type="checkbox"/> Done

If a set limit has been exceeded, a message box will pop up. This will not stop a sequence or run (the information is intended only for planning of maintenance activities). If you press **Reset**, the limits will be removed. **Ignore** will continue to keep the EMF flag set.

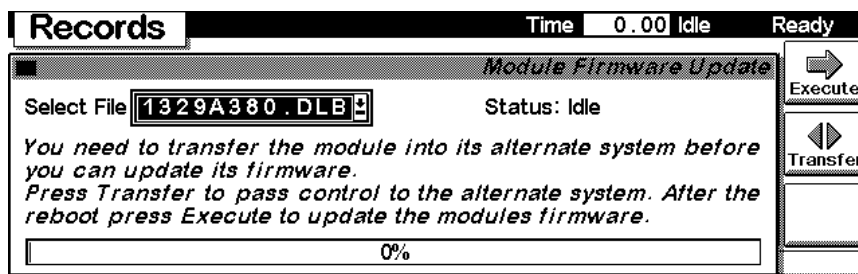
Records		Time	0.00	Idle	Ready
Module	<b># Valve cycles limit exceeded</b>				
Control	The number of valve cycles defined for the autosampler has exceeded its defined limit.				
Autosai					
		<input type="checkbox"/>		<input type="checkbox"/>	
		<input checked="" type="checkbox"/> Ignore		<input checked="" type="checkbox"/> Reset	
					<input checked="" type="checkbox"/> Done

### Firmware Update

Use the Esc key to receive **Views** on the F5 key. Choose **System** from the pull-down menu. Use the F3 key (**Records**) to select the ALS. Use the F5 key (**FW Update**) to enter the Update section. If you want to update the resident firmware (together with specific main firmware revisions), select the a file from the PCMCIA card (RESnnnn.DLB) and press execute. If you want to update the main firmware, press F7 key (**Transfer**) to turn the module into the resident mode (LED on module should blink yellow).



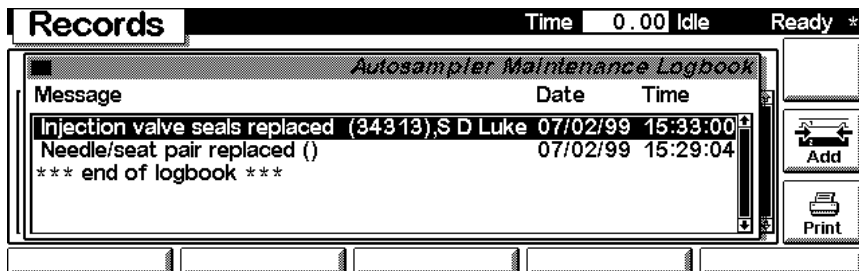
Use the Esc key to receive **Views** on the F5 key. Choose **System** from the pull-down menu. Use the F3 key (**Records**) to select the ALS. Use the F5 key (**FW Update**) to enter the Update section. Select the a file from the PCMCIA card (1313nnnn.DLB or 1329nnnn.DLB) and press execute. When the update has finished the update, press F7 key (**Transfer**) to return the module into the normal mode (LED on module should stays yellow).



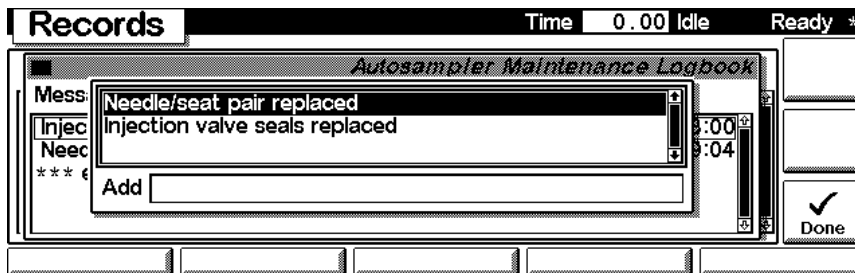


### Maintenance activities

Use the Esc key to receive **Views** on the F5 key. Choose **System** from the pull-down menu. Use the F3 key (**Records**) to select the ALS. Use the F4 key (**Maint log**) to view and edit the maintenance logbook.



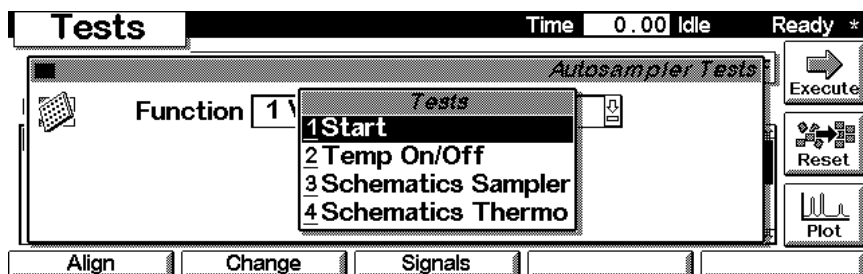
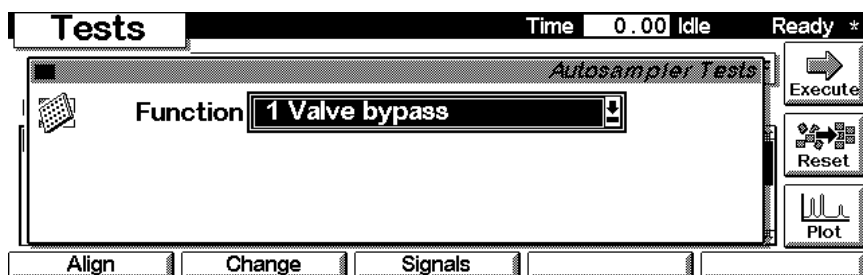
Use the F7 key (**Add**) to add new maintenance activities.

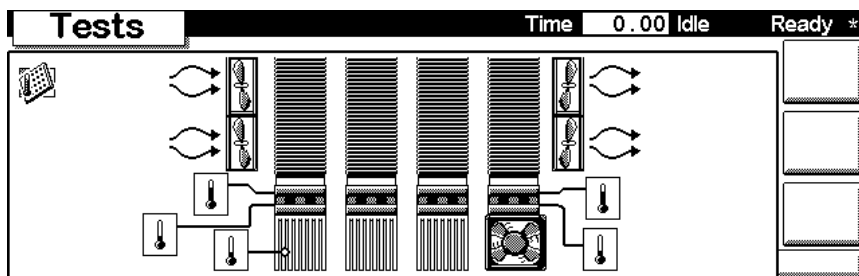
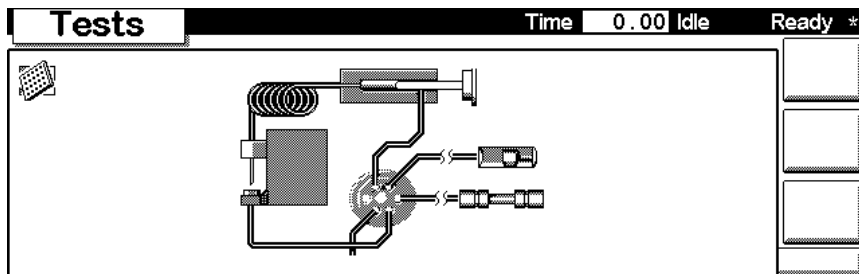


## Diagnostics and Tests

### Tests screen

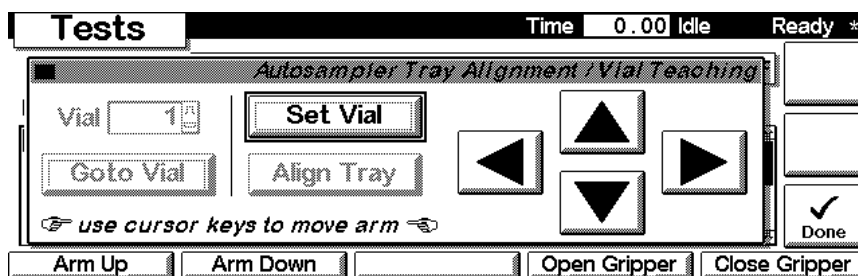
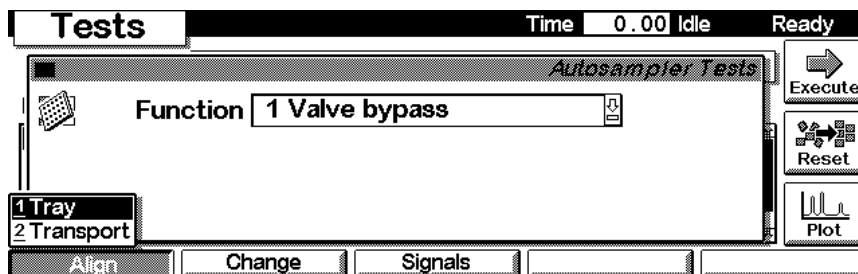
Use the Esc key to receive **Views** on the F5 key. Choose **System** from the pull-down menu. Use the F3 key (**Tests**) to select the ALS. Several tests are available to test the Agilent 1100 autosampler. Additional test are listed in the function box. Press the **m**-key to open the context sensitive menu. Menu item 3 (**Schematics**) will popup the ALS and ALS thermostat diagram.





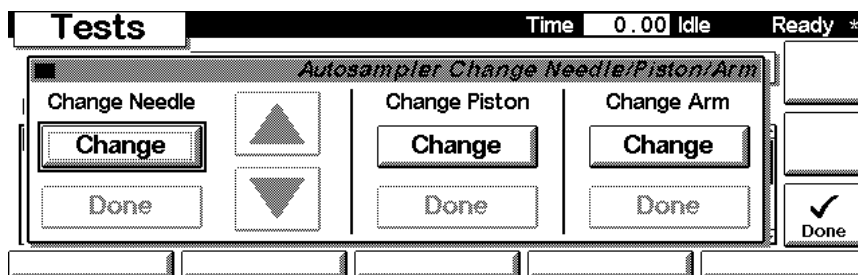
### Tray and Transport Alignment

Use the F1 key (**Align**) to align the autosampler tray or transport.



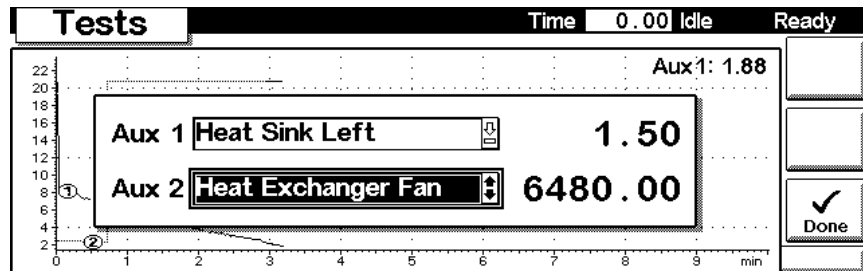
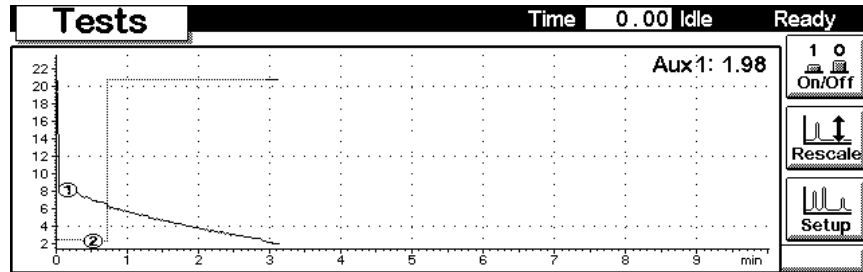
### Change Needle, Piston and Arm

Use the F2 key (**Change**) to start the maintenance procedures for changing the autosampler needle, piston and gripper arm.

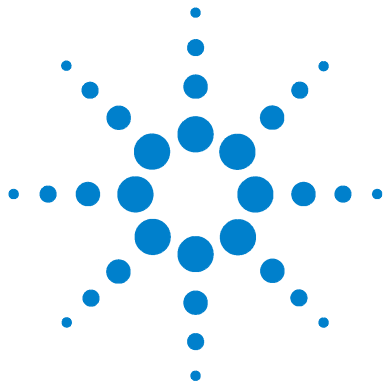


## Signals

Use the F8 key (**Signals**) to display the signals available from the ALS thermostat. Press F6 key (**Setup**). Here you can select which signals are shown.



## **8 Introduction to the Control Module**



## 9 Specifications

Performance Specifications 280



## Performance Specifications

**Table 85** Performance Specifications Agilent 1100 Series Autosampler (G1313A) and Thermostatted Autosampler (G1329A). Valid when standard 100  $\mu\text{l}$  metering head installed.

Type	Specification
GLP features	Early maintenance feedback (EMF), electronic records of maintenance and errors
Communications	Controller-area network (CAN). GPIB (IEEE-448), RS232C, APG-remote standard, optional four external contact closures and BCD vial number output
Safety features	Leak detection and safe leak handling, low voltages in maintenance areas, error detection and display
Injection range	0.1 – 100 $\mu\text{l}$ in 0.1 $\mu\text{l}$ increments Up to 1500 $\mu\text{l}$ with multiple draw (hardware modification required)
Replicate injections	1 – 99 from one vial
Precision	Typically < 0.5 % RSD of peak areas from 5 – 100 $\mu\text{l}$ , Typically < 1 % RSD of peak areas from 1 – 5 $\mu\text{l}$
Minimum sample volume	1 $\mu\text{l}$ from 5 $\mu\text{l}$ sample in 100 $\mu\text{l}$ microvial, or 1 $\mu\text{l}$ from 10 $\mu\text{l}$ sample in 300 $\mu\text{l}$ microvial
Carryover	Typically < 0.1 %, < 0.05 % with external needle cleaning
Sample viscosity range	0.2 – 50 cp
Replicate injections per vial	1 – 99
Sample capacity	100 $\times$ 2-ml vials in 1 tray 40 $\times$ 2-ml vials in $\frac{1}{2}$ tray 15 $\times$ 6-ml vials in $\frac{1}{2}$ tray (Agilent vials only)
Injection cycle time	Typically 50 s depending on draw speed and injection volume



**Table 86** Performance Specifications Agilent 1100 Series Autosampler (G1313A) and Thermostatted Autosampler (G1329A).  
Valid when standard 900 µl metering head installed.

Type	Specification
Pressure	Operating range 0-20 MPa (0-200 bar, 0-2950 psi)
GLP features	Early maintenance feedback (EMF), electronic records of maintenance and errors
Communications	Controller-area network (CAN). GPIB (IEEE-448), RS232C, APG-remote standard, optional four external contact closures and BCD vial number output
Safety features	Leak detection and safe leak handling, low voltages in maintenance areas, error detection and display
Injection range	0.1 – 900 µl in 0.1 µl increments (recommended 1 µl increments) Up to 1800 µl with multiple draw (hardware modification required)
Replicate injections	1 – 99 from one vial
Precision	Typically < 0.5 % RSD of peak areas from 5 – 2000 µl, Typically < 1 % RSD of peak areas from 2000 – 5000 µl, Typically < 3 % RSD of peak areas from 1 – 5 µl
Minimum sample volume	1 µl from 5 µl sample in 100 µl microvial, or 1 µl from 10 µl sample in 300 µl microvial
Carryover	Typically < 0.1 %, < 0.05 % with external needle cleaning
Sample viscosity range	0.2 – 50 cp
Sample capacity	100 × 2-ml vials in 1 tray 40 × 2-ml vials in ½ tray 15 × 6-ml vials in ½ tray (Agilent vials only)
Injection cycle time	Typically 50 s, depending on draw speed and injection volume

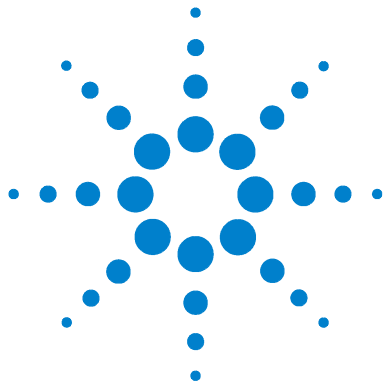
**Table 87** Performance Specifications Agilent 1100 Series Thermostatted Micro Autosampler (G1389A)

Type	Specification
Sample capacity	100 x 2 ml vials in 1 tray. Microvials (100 or 300 µl) with sleeves (reduced cooling performance with microvials)
Settable injection volume	0.01 to 8 µl with small loop capillary 0.01 to 40 µl with extended loop capillary
Precision	Typically < 0.5 % RSD from 5 to 40 µl Typically < 1 % RSD from 1 to 5 µl Typically < 3 % RSD from 0.2 to 1 µl
Minimum sample volume	1 µl from 5 µl sample in 100 µl microvial, or 1 µl from 10 µl sample in 300 µl microvials
Carryover	Typically < 0.1 % without automated needle wash Typically < 0.05 % with external needle cleaning and 1 µl injection volume
Sample viscosity range	0.2 - 5 cp
Recommended pH-range	1.0 - 8.5 solvent with pH < 2.3 should not contain acids which attack stainless steel. Upper pH range is limited by fused silica capillaries
Material in contact with solvent	Stainless steel, sapphire, PTFE, PEEK, fused silica, Vespel
GLP features	Early maintenance feedback (EMF), electronic records of maintenance and errors
Communications	Controller-area network (CAN). GPIB (IEEE-448), RS232C, APG-remote standard, optional four external contact closures and BCD vial number output
Safety features	Leak detection and safe leak handling, low voltages in maintenance areas, error detection and display
Housing	All material recyclable

**Table 88** Performance Specifications Agilent 1100 Series Preparative Autosampler (G2260A)

Type	Specification
Pressure	Operating range 0-40 MPa (0-400 bar, 0-5800psi)
GLP features	Early maintenance feedback (EMF), electronic records of maintenance and errors
Communications	Controller-area network (CAN). GPIB (IEEE-448), RS232C, APG-remote standard, optional four external contact closures and BCD vial number output
Safety features	Leak detection and safe leak handling, low voltages in maintenance areas, error detection and display
Injection range	0.1 – 900 $\mu$ l in 0.1 $\mu$ l increments (recommended 1 $\mu$ l increments) Up to 1800 $\mu$ l with multiple draw (hardware modification required) Up to 5000 $\mu$ l with multiple draw (hardware modification required)
Replicate injections	1 – 99 from one vial
Precision	Typically < 0.5 % RSD of peak areas from 5 – 2000 $\mu$ l, Typically < 1 % RSD of peak areas from 2000 – 5000 $\mu$ l, Typically < 3 % RSD of peak areas from 1 – 5 $\mu$ l
Minimum sample volume	1 $\mu$ l from 5 $\mu$ l sample in 100 $\mu$ l microvial, or 1 $\mu$ l from 10 $\mu$ l sample in 300 $\mu$ l microvial
Sample viscosity range	0.2 – 50 cp
Sample capacity	100 $\times$ 2-ml vials in 1 tray 15 $\times$ 6-ml vials in 1/2 tray (Agilent vials only)
Injection cycle time	Typically 50 s, depending on draw speed and injection volume





## A Safety Information

General Safety Information	286
Lithium Batteries Information	289
Radio Interference	290
Sound Emission	291
Solvent Information	292
Agilent Technologies on Internet	293



## General Safety Information

The following general safety precautions must be observed during all phases of operation, service, and repair of this instrument. Failure to comply with these precautions or with specific warnings elsewhere in this manual violates safety standards of design, manufacture, and intended use of the instrument. Agilent Technologies assumes no liability for the customer's failure to comply with these requirements.

### General

This is a Safety Class I instrument (provided with terminal for protective earthing) and has been manufactured and tested according to international safety standards.

### Operation

Before applying power, comply with the installation section. Additionally the following must be observed.

Do not remove instrument covers when operating. Before the instrument is switched on, all protective earth terminals, extension cords, auto-transformers, and devices connected to it must be connected to a protective earth via a ground socket. Any interruption of the protective earth grounding will cause a potential shock hazard that could result in serious personal injury. Whenever it is likely that the protection has been impaired, the instrument must be made inoperative and be secured against any intended operation.

Make sure that only fuses with the required rated current and of the specified type (normal blow, time delay, and so on) are used for replacement. Do not use repaired fuses and avoid to short-circuit fuseholders.

Some adjustments described in the manual, are made with power supplied to the instrument, and protective covers removed. Energy available at many points may, if contacted, result in personal injury.

### **WARNING**

**Any adjustment, maintenance, and repair of the opened instrument under voltage is forbidden.**

**WARNING**

**Disconnect the instrument from the line and unplug the power cord before maintenance.**

Do not operate the instrument in the presence of flammable gases or fumes. Operation of any electrical instrument in such an environment constitutes a definite safety hazard.

Use the instrument only with Agilent CAN connected instrument or with remote controlled instrument.





Do not install substitute parts or make any unauthorized modification to the instrument.

Capacitors inside the instrument may still be charged, even though the instrument has been disconnected from its source of supply. Dangerous voltages, capable of causing serious personal injury, are present in this instrument. Use extreme caution when handling, testing and adjusting.

### Safety Symbols

Table 89 shows safety symbols used on the instrument and in the manuals.

**Table 89** Safety Symbols

Symbol	Description
	The apparatus is marked with this symbol when the user should refer to the instruction manual in order to prevent risk of harm to the operator and to protect the apparatus against damage.
	Indicates dangerous voltages.
	Indicates a protected conductor terminal.
	Eye damage may result from directly viewing the light produced by the Xenon flash lamp used in this product. Always turn the xenon flash lamp off before removing it.

**WARNING**

A warning alerts you to situations that could cause physical injury or damage to the equipment. Do not proceed beyond a warning until you have fully understood and met the indicated conditions.

---

**CAUTION**

A caution alerts you to situations that could cause a possible loss of data. Do not proceed beyond a caution until you have fully understood and met the indicated conditions.

---



## Lithium Batteries Information

**WARNING**

Danger of explosion if battery is incorrectly replaced. Replace only with the same or equivalent type recommended by the equipment manufacturer. Lithium batteries may not be disposed-off into the domestic waste.

Transportation of discharged Lithium batteries through carriers regulated by IATA/ICAO, ADR, RID, IMDG is not allowed. Discharged Lithium batteries shall be disposed off locally according to national waste disposal regulations for batteries.

---

**WARNING**

Lithiumbatteri - Eksplosionsfare ved fejlagtig håndtering. Udskiftning må kun ske med batteri af samme fabrikat og type. Lever det brugte batteri tilbage til leverandøren.

---

**WARNING**

Lithiumbatteri - Eksplosionsfare. Ved udskiftning benyttes kun batteri som anbefalt av apparatfabrikanten. Brukt batteri returneres apparatleverandøren.

---

**NOTE**

Bij dit apparaat zijn batterijen geleverd. Wanneer deze leeg zijn, moet u ze niet weggoien maar inleveren als KCA.



## **Radio Interference**

Never use cables other than the ones supplied by Agilent Technologies to ensure proper functionality and compliance with safety or EMC regulations.

**Test and Measurement**

If test and measurement equipment is operated with equipment unshielded cables and/or used for measurements on open set-ups, the user has to assure that under operating conditions the radio interference limits are still met within the premises.

## Sound Emission

### Manufacturer's Declaration

This statement is provided to comply with the requirements of the German Sound Emission Directive of 18 January 1991.

This product has a sound pressure emission (at the operator position)  $< 70$  dB.

- Sound Pressure  $L_p < 70$  dB (A)
- At Operator Position
- Normal Operation
- According to ISO 7779:1988/EN 27779/1991 (Type Test)

## Solvent Information

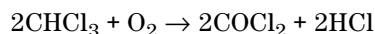
Observe the following recommendations on the use of solvents.

### Solvents

Brown glass ware can avoid growth of algae.

Always filter solvents, small particles can permanently block the capillaries. Avoid the use of the following steel-corrosive solvents:

- Solutions of alkali halides and their respective acids (for example, lithium iodide, potassium chloride, and so on).
- High concentrations of inorganic acids like nitric acid, sulfuric acid especially at higher temperatures (replace, if your chromatography method allows, by phosphoric acid or phosphate buffer which are less corrosive against stainless steel).
- Halogenated solvents or mixtures which form radicals and/or acids, for example:



This reaction, in which stainless steel probably acts as a catalyst, occurs quickly with dried chloroform if the drying process removes the stabilizing alcohol.

- Chromatographic grade ethers, which can contain peroxides (for example, THF, dioxane, di-isopropylether) such ethers should be filtered through dry aluminium oxide which adsorbs the peroxides.
- Solutions of organic acids (acetic acid, formic acid, and so on) in organic solvents. For example, a 1 % solution of acetic acid in methanol will attack steel.
- Solutions containing strong complexing agents (for example, EDTA, ethylene diamine tetra-acetic acid).
- Mixtures of carbon tetrachloride with 2-propanol or THF.

## Agilent Technologies on Internet

For the latest information on products and services visit our worldwide web site on the Internet at:

<http://www.agilent.com>

Select “Products” - “Chemical Analysis”

It will provide also the latest firmware of the Agilent 1100 series modules for download.

## **A Safety Information**

# Index

## A

address switch, 246  
Agilent on internet, 293  
air circulation, 15  
analog signal output, 242  
Analytical, 174  
analytical head, 220  
APG remote interface, 242  
ASIC, 232  
ASM board, 232  
autosampler accessory kit contents, 18, 186, 187, 188, 189  
autosampler control, 230  
autosampler main board, 232

## B

battery, 233  
    safety information, 289  
BCD board, 239  
BCD/LAN board, 239  
bench space, 15  
boards  
    interface board (BCD/LAN), 239  
bypass, 217  
bypassing the autosampler, 37

## C

cable  
    connecting APG remote, 23, 25  
    connecting CAN, 23, 25  
    connecting GPIB, 23, 25  
    connecting LAN, 23, 25  
    connecting the ChemStation, 23, 25  
    connecting the power, 23, 25  
cables, 194  
CAN interface, 242  
capillaries, 33  
change metering seal, 86  
change needle, 84

choice of vials and caps, 48  
cleaning the autosampler, 105  
common electronics, 232  
condensation, 16  
configuration switch, 246  
control module  
    Analysis screens, 255  
    Config screens, 268  
    Control screens, 267  
    Error Log screen, 270  
    Firmware Update screens, 272  
    Info Log and EMF screen, 270  
    Maintenance screens, 273  
    Method screens, 265  
    Records screen, 269  
    Run Times screen, 262  
    Settings screens, 258  
    Signal Plot screens, 263  
    Status screens, 263  
    System screen, 266  
    Tests and Diagnostic screens, 274  
    Thermostat screen, 262  
    Timetable screens, 260

## D

damaged packaging, 17  
delay, 40  
delay volume, 37, 40  
delivery checklist, 17  
DRAW, 48  
draw speed, 48

## E

EJECT, 48  
eject speed, 48  
electronics, 230  
    ASIC, 232  
    ASM board, 232  
    battery, 233  
    electronic fuses, 233

fan drive, 233  
firmware, 237  
    sample transport control, 234  
    sampling unit control, 235  
    sensors, 231  
environment, 14, 16  
error messages, 52, 55  
    arm movement failed, 68  
    compensation sensor open, 63  
    compensation sensor short, 64  
    fan failed, 65  
    ignition without cover, 66  
    initialization failed, 74  
    initialization with vial, 77  
    invalid vial position, 81  
    leak, 60  
    leak sensor open, 61  
    leak sensor short, 62  
    metering home failed, 75  
    missing vial, 73  
    missing wash vial, 80  
    motor failed, 76  
    needle down failed, 72  
    needle up failed, 71  
    remote timeout, 58  
    restart without cover, 67  
    safety flap missing, 78  
    shutdown, 57  
    synchronization lost, 59  
    time-out, 56  
    valve to bypass failed, 69  
    valve to mainpass failed, 70  
    vial in gripper, 79  
ESD (electrostatic discharge) strap, 106

## F

failure, 52  
firmware, 237  
    main system, 237  
    resident system, 237  
    updates, 238

## Index

flow connections, 33  
fuses, 14  
  BCD board, 239  
  power supply, 252

## G

GPIB  
  default addresses, 242  
  interface, 242  
 gripper, 222  
  alignment, 52  
  external vials, 52  
 gripper alignment, 89  
 gripper fingers, 222  
 gripper-position verification, 91

## H

half trays, 34  
hall sensor, 231

## I

injection sequence, 217  
injection valve, 214, 219, 221  
injection volume precision, 48  
injection volumes, 48  
injection volumes less than 2 µl, 48  
installing the autosampler, 26  
  flow connections, 33  
  interface cables, 26  
  power cable, 26  
  safety, 26  
  sample trays, 34  
installing the sample tray, 34  
installing the thermostatted autosampler  
  interface cables, 29  
  power cable, 29  
  power cable and interface cable, 30  
  preparation, 29  
  safety, 26, 29  
  tray cover and front cover, 37  
installing the tray cover front door, 37  
instrument status indicator, 54  
interface board (BCD/LAN), 239  
interfaces  
  analog signal output, 242  
  APG remote, 242

CAN, 242  
GPIB, 242  
  overview, 241  
  RS-232C, 244  
internet, 293  
introduction to the autosampler, 214  
IR sensor, 231

## L

LAN  
  interface board, 239  
LAN cables, 212  
LAN interface board, 240  
low volume injections, 48  
low-volume capillary kit, 37  
low-volume capillary kit, 192

## M

main board, 232  
mainpass, 217  
maintenance functions, 52, 82  
  change metering seal, 86  
  change needle, 84  
message  
  ignition without cover, 66  
  metering device, 48, 219  
  metering seal, 174  
  metering seal 900 µl, 174, 176  
micro thermostatted autosampler accessory  
  kit contents, 20  
microswitches, 231  
missing parts, 17  
multi-draw option, 214

## N

needle drive, 219, 220  
Needle-Seat Assembly (Video Clip)" on  
  page 124, 85  
numbering of vials, 34

## O

optimizing performance  
  automated needle wash, 48  
  bypassing the autosampler, 37  
  delay volume, 48

delay-volume adjustment, 48  
early maintenanc, 48  
inject-valve seal, 48  
low-volume capillary kit, 37, 48  
minimizing delay volume, 37, 40

## P

park arm, 87  
park transport assembly, 17, 37  
parts and materials, 17  
  900 µl injection upgrade kit, 192  
  accessory kit, 187  
  als thermostat, 171  
  analytical-head assembly, 174  
  analytical-head assembly (optional 900  
  microlitre), 174  
  autosampler accessory kit, 186  
  autosampler main assemblies, 169  
  autosampler sampling unit  
  assembly, 171  
  cables, 194  
  cover parts, 180  
  external tray, 193  
  foam parts, 181  
  injection-valve assembly, 177  
  leak system parts, 183  
  main assemblies, 168  
  maintenance kit, 190  
  micro thermostatted autosampler acc.  
  kit, 188  
  multi-draw kit, 191  
  power and status light pipes, 182  
  preparative ALS acc. kit, 189  
  preparative-head assembly, 176  
  sheet metal kit, 179  
  thermostatted autosampler accessory  
  kit, 187  
  transport assembly, 169, 171  
  tray cover parts, 180  
  vial trays and tray base, 184  
parts identification  
  cables - LAN cables, 212  
performance specifications, 280  
  autosampler, 280, 281  
  preparative autosampler, 283  
  thermostatted micro autosampler, 282  
physical specifications, 16, 17  
power consideration, 14



power cords, 15  
 power requirements, 14  
 power supply  
   description, 251  
   specifications, 252  
 power supply indicator, 53  
 preparative autosampler accessory kit  
   contents, 21  
 preparative head, 220

## R

reflection sensor, 231  
 repair procedures, 107  
 repairs  
   ASM board, 154  
   exchanging internal parts, 130  
   fan, 152  
   injection-valve assembly, 144  
   leak sensor, 164  
   main board (ASM), 154  
   main cover, 131  
   metering plunger, 122  
   metering seal, 122  
   metering-drive motor and belt, 147  
   needle assembly, 109  
   needle-drive motor and belt, 149  
   needle-seat assembly, 112  
   power supply, 161  
   rotor seal, 118  
   sampling unit, 138  
   simple repairs, 108  
   stator face, 115  
   SUD board, 159  
   top cover and foam, 132, 134  
   transport assembly, 136  
   using the ESD strap, 106  
 restart without cover, 67  
 RS-232  
   cable kit to PC, 211  
 RS-232C  
   communication settings, 248  
   interface, 244  
   settings, 248

## S

safety information  
 on lithium batteries, 289

sample trays, 34  
   numbering of vial positions, 35  
 sampling sequence, 216  
 sampling unit, 219  
 seals  
   metering seal, 174, 176  
 sensors, 231  
 shipping, 17, 37, 87  
 simple repairs, 108  
 site requirements, 14  
 specifications, 16, 17, 280  
 stack configuration, 23, 25  
   rear view, 23, 25  
 stator, 221  
 status indicator, 52  
 status indicators, 53  
 step commands, 91  
 step functions, 52  
 stepper motor, 220  
 storage, 16

## T

temperature, 16, 280  
 thermostatted autosampler accessory kit  
   contents, 18  
 theta-axis, 222  
 Time-Out, 56  
 transport, 37, 87  
 transport assembly, 222  
 transport mechanism, 214

## U

unpacking the autosampler, 17  
 URL, 293

## V

valve capillaries, 33  
 verifying the gripper position, 91  
 vial contents temperature, 280  
 vial numbering, 34  
 vial racks, 214  
 vial tray, 37  
 vials, 214  
 viscous samples, 48  
 volume, 40

## W

weight, 15

## X

X-axis, 222

## Z

Z-axis, 222







## **In This Book**

This manual contains technical reference information about the Agilent 1100 Series Standard, Thermostatted, Micro and and Preparative Autosamplers.

The manual describes the following:

- installing the autosamplers,
- optimizing performance,
- troubleshooting and test functions,
- repairing the autosamplers,
- parts and materials,
- introduction to the autosamplers,
- screens of the local control module
- specifications
- safety and warranty

