

Operation Quick Reference Guide

Sampler Pre-run Checklist

Use this checklist to make sure the sampler is ready before you begin a run.

- Sample vials are half full.
- Cap is centered, no wrinkles, septum is flat.
- Sample vial positions match the run parameters.
- Tray quadrants snapped in place (with tray).
- 4.5 mL of fresh solvent in each solvent bottle.
- Waste bottles are empty.
- Two waste bottles (with tray).
- There is enough solvent and waste capacity for your sample vials.
- Syringe is new or clean.
- Syringe design and size are correct.
- Plunger is secure in plunger carrier loop.
- Needle is aligned with septum retainer nut.
- Syringe is rinsed with solvent.
- GC inlet liner is clean and deactivated.
- GC inlet liner is correct type for injection technique.
- GC inlet septum type is correct and the septum is less than 200 injections old.
- Correct septum nut is installed in GC inlet.
- Correct nanoliter enable setting for required injection volume.
(GC or integrator control only)
- Correct cool on-column inlet insert installed for your column/syringe.

Running a sample

To operate your 7683 Automatic Liquid Sampler:

1. Install a clean syringe. See *Installing A Syringe* on page 16.
2. Fill the solvent bottles and load them into the turret. See *Preparing The Solvent And Waste Bottles* on page 13.
3. Load the waste bottles into the turret. See *Preparing The Solvent And Waste Bottles* on page 13.
4. Load the sample vials into the turret or into the tray. See *Preparing Sample Vials* on page 9.
5. Load (or program) the GC sequence. See your 6890 GC or Agilent ChemStation documentation.
6. Run the GC sequence.

When the GC becomes ready, the 7683 Automatic Liquid Sampler begins the injections.

Agilent 7683 Automatic
Liquid Sampler

©Agilent Technologies
1997–2000

Target® is a registered trademark and DPTM is a trademark of National Scientific Company.

All Rights Reserved. Reproduction, adaptation, or translation without permission is prohibited, except as allowed under the copyright laws.

Part No. G2612-90117

Replaces Part No. G2612-90110

First edition, Jan 2000

Printed in USA

HP® is a registered trademark of Hewlett Packard Co.

Microsoft®, Windows®, and Windows NT® are registered trademarks of Microsoft Corp.

Safety Information

The 7683 Automatic Liquid Sampler meets the following IEC (International Electrotechnical Commission) classifications: Safety Class 1, Transient Overvoltage Category II, and Pollution Degree 2. This unit has been designed and tested in accordance with recognized safety standards and designed for use indoors. Whenever the safety protection of the 7683 Automatic Liquid Sampler has been compromised, disconnect the unit from all power sources and secure the unit against unintended operation.

The recyclable carbon monofluoride lithium battery is BR-2/3 A 1,200 mAh. Fuses F001 and F002 are 3 A, 250 Vac, IEC 127 Type T. Fuses F201 and F202 are 10 A, 250 Vac, IEC 127 Type T. Fuse F101 is a 0.5 A, 250 Vac.

Warnings in this manual or on the instrument must be observed during all phases of operation, service, and repair of this instrument. Failure to comply with these precautions violates safety standards of design and the intended use of the instrument. Agilent Technologies assumes no liability for the customer's failure to comply with these requirements.

Refer servicing to qualified service personnel. Substituting parts or performing any unauthorized modification to the instrument may result in a safety hazard. Disconnect the AC power cord before removing covers. The customer should not attempt to replace the battery or fuses in this instrument.

Safety Symbols

This manual contains safety information that should be followed by the user to ensure safe operation.

WARNING

A warning calls attention to a condition or possible situation that could cause injury to the user.

CAUTION

A caution calls attention to a condition or possible situation that could damage or destroy the product or the user's work.

Electromagnetic Compatibility

This device complies with the requirements of CISPR 11. Operation is subject to the following two conditions:

- 1 This device may not cause harmful interference.
- 2 This device must accept any interference received, including interference that may cause undesired operation.

If this equipment does cause harmful interference to radio or television reception, which can be determined by turning the equipment off and on, the user is encouraged to try one or more of the following measures:

- 1 Relocate the radio or antenna.
- 2 Move the device away from the radio or television.
- 3 Plug the device into a different electrical outlet, so that the device and the radio or television are on separate electrical circuits.
- 4 Make sure that all peripheral devices are also certified.
- 5 Make sure that appropriate cables are used to connect the device to peripheral equipment.
- 6 Consult your equipment dealer, Agilent Technologies, or an experienced technician for assistance.
- 7 Changes or modifications not expressly approved by Agilent Technologies could void the user's authority to operate the equipment.

Sound Emission Certification for Federal Republic of Germany

If Test and Measurement Equipment is operated with unscreened cables and/or used for measurements in open set-ups, users have to assure that under these operating conditions the Radio Interference Limits are still met at the border of their premises.

The following information is provided to comply with the requirements of the German Sound Emission Directive dated January 18, 1991. Sound pressure $L_p < 57$ dB(A) during normal operation at the operator position according to ISO 7779 (Type Test).

When operating the Agilent Automatic Liquid Sampler, the sound pressure ≈ 68 dB(A) during short burst injection pulses.

Schallemission

Werden Meß- und Testgeräte mit ungeschirmten Kabeln und/oder in offenen Meßaufbauten verwendet, so ist vom Betreiber sicherzustellen, daß die Funk-Eströbedingungen unter Betriebsbedingungen an seiner Grundstücksgrenze eingehalten werden.

Diese Information steht im Zusammenhang mit den Anforderungen der Maschinenlärminformationsverordnung vom 18 Januar 1991.

Schalldruckpegel $LP < 57$ dB(A) Am Arbeitsplatz
Normaler Betrieb
Nach DIN 45635 T. 19
(Typprüfung)

Bei Betrieb des Agilent Automatischer Flüssigkeitsprobengeber treten beim Öffnen des Ventils impulsförmig Schalldrucke LP bis ca. 68 dB(A) auf.

Contents

About your 7683 Automatic Liquid Sampler	1
Capabilities	2
Injection Volume	3
Pre-run Checklist	4
Running A Sample	5
Interrupting A Run Or Sequence	6
Sampler Response To Interruptions	6
Restarting An Interrupted Sequence	7
Running A Priority Sample	8
Preparing Sample Vials	9
Selecting Sample Vials	9
Labeling Sample Vials	10
Sample Vial Septa	10
Filling Sample Vials	11
If You Do Not Use The Optional 100-vial Tray	11
If You Use The Optional 100-vial Tray	12
Preparing The Solvent And Waste Bottles	13
Using Two Injectors	14
With A Tray	14
Without A Tray	14
Syringes	15
Inspecting A Syringe	15
Installing A Syringe	16
Removing A Syringe	18
Cool On-column Injection	19
Controlling Sample Vial Temperatures	20

About your 7683 Automatic Liquid Sampler

The 7683 Automatic Liquid Sampler system, shown in Figure 1, can include:

- One G2612A ALS interface board (6890 only)
- One or 2 G2613A injector module(s)
- G2614A 100 vial tray (optional, 6890)
- G1926A Bar Code Reader (optional, 6890—requires INET integrator or Agilent ChemStation)

The sampler draws a sample from a 2 mL or 100 μ L vial and injects it into the gas chromatograph (GC) inlet at a predetermined time. You can use up to 8 sample vials with the turret alone, or up to 100 sample vials with the optional G2614A tray and the standard turret.

In addition, the sampler can:

- Perform solvent pre- and post-injection washes
- Perform sample pre-injection washes
- Perform sample pumps
- Extend the sample draw time for viscous samples
- Inject different sample amounts from different sample vials
- Interrupt a running sequence to run priority samples and then resume the sequence
- Perform cool on-column injections into 250 μ m, 320 μ m, and 530 μ m columns

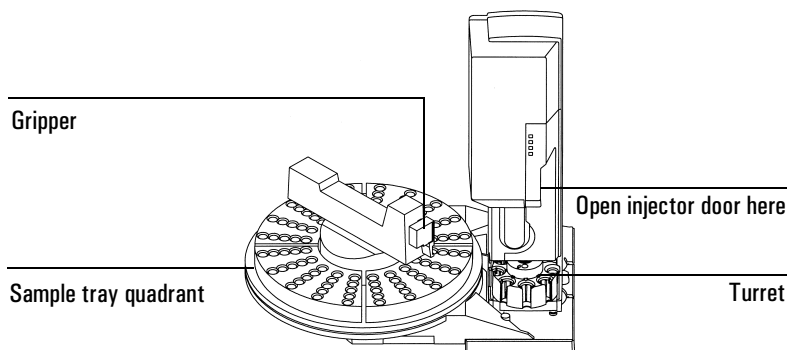

Figure 1 The 7683 Automatic Liquid Sampler

Capabilities

Table 1 summarizes the capabilities of the 7683 Automatic Liquid Sampler.

Table 1 Automatic Liquid Sampler Capabilities

Parameter	Range
Syringe size	5, 10, 25, 50, or 100 μL
Number of sample vials	up to 8 without tray or 100 with tray
Number of injections per vial	1 to 99
Injection volume Minimum	0.1 μL (5 μL syringe)
Maximum	50.0 μL (100 μL syringe)
Plunger speed ($\mu\text{L}/\text{sec}$)	Slow Fast
5 μL syringe	2.5 50
10 μL syringe	5 100
25 μL syringe	12.5 250
50 μL syringe	25 500
100 μL syringe	50 1000
Overall injection time (approximate)	0.1 sec (Standard) 4 sec (Cool on-column)
Sampling depth	-2 to +30 mm above default
Sampling viscosity delay	0 to 7 seconds
Number of sample prewashes	0 to 15
Number of sample pumps	0 to 15
Number of solvent prewashes	0 to 15 (per bottle)
Number of solvent post-washes	0 to 15 (per bottle)
Multiple injection mode (with PTV inlet only)	
Number of injections	1 to 99
Injection delay time	0 to 60 seconds
Preinjection dwell	0 to 1 minute
Postinjection dwell	0 to 1 minute

Injection Volume

When using 6890 GC (or integrator) control, the injection volume depends on the sample volume setting, the syringe size, and whether the GC's nanoliter enable setting is on or off. See Table 2.

Table 2 Injection volumes for 6890 GC or integrator control

6890 Sample volume setting (syringe stops)		7683 Injection volume (μL)				
Nanoliter enable Off	Nanoliter enable On	5 μL Syringe	10 μL Syringe	25 μL Syringe	50 μL Syringe	100 μL Syringe
—	1	0.1	0.2	0.5	1.0	2.0
1	2	0.5	1.0	2.5	5.0	10.0
2	3	1.0	2.0	5.0	10.0	20.0
3	4	1.5	3.0	7.5	15.0	30.0
4	5	2.0	4.0	10.0	20.0	40.0
5	—	2.5	5.0	12.5	25.0	50.0

When using the 6850 GC or Agilent ChemStation, you may select the injection volume directly.

Pre-run Checklist

Use this checklist to make sure the sampler is ready before you begin.

- Sample vials are half full.
- Cap is centered, no wrinkles, septum is flat.
- Sample vial positions match the run parameters.
- Tray quadrants snapped in place (with tray).
- 4.5 mL of fresh solvent in each solvent bottle.
- Waste bottles are empty.
- Two waste bottles (with tray).
- There is enough solvent or waste capacity for your sample vials.
- Syringe is new or clean.
- Syringe design and size are correct.
- Plunger is secure in plunger carrier loop.
- Needle is aligned with septum retainer nut.
- Syringe is rinsed with solvent.
- GC inlet liner is clean and deactivated.
- GC inlet liner is correct type for injection technique.
- GC inlet septum type is correct.
- GC inlet septum is less than 200 injections old.
- Correct septum nut is installed in GC inlet.
- Correct nanoliter enable setting for required injection volume (6890 GC or integrator control only).
- Correct cool on-column inlet insert installed for your column/syringe.

Running A Sample

WARNING

When running a sample, keep your hands away from the syringe needle. The needle is sharp and may contain hazardous chemicals.

To operate your automatic liquid sampler:

1. Install a clean syringe. See *Installing a syringe*.
2. Fill the solvent bottles and load them into the turret. See *Preparing the solvent and waste bottles*.
3. Load the waste bottles into the turret. See *Preparing the solvent and waste bottles*.
4. Load the sample vials into the turret or into the tray. See *Preparing sample vials*.
5. Load (or program) the GC sequence. See your 6850/6890 GC or Agilent ChemStation documentation.
6. Run the GC sequence.

When the GC becomes ready, the 7683 Automatic Liquid Sampler begins the injections.

Interrupting A Run Or Sequence

The following events interrupt a run:

- **Power failures** — The power to the GC or controlling device fails.
- **Stop commands** — The [stop] button on the GC or integrator is pressed, or the **Stop Run/Abort** option is selected from the Agilent ChemStation.
- **Safety or operator faults** — The sampler recognizes safety or operator fault(s), such as:
 - The syringe access door was opened.
 - The injector was moved on the GC during injection.
 - The tray failed to deliver a vial.

Sampler Response To Interruptions

The sampler responds to interruptions differently depending on the controlling device.

3396/3397 integrator with INET

- **Power failure** — Interrupts the sequence. The integrator recovers and restarts the sequence beginning with repeat injection(s) from the sample vial that was being used when the power was interrupted.
- **Stop commands** — Aborts the run. Restart the sequence (see page 7).
- **Safety or operator faults** — Aborts the run. Restart the sequence (see page 7).

6850/6890 or Agilent ChemStation

If the interruption was caused by a problem that the sampler recognizes, a message will appear on the GC or Agilent ChemStation. For more information, refer to your Agilent *7683 Installation Guide* and GC or Agilent ChemStation documentation.

- **Power failure** — Aborts the run. Restart the sequence (see page 7).
- **Stop commands** — Aborts the run. Restart the sequence (see page 7).
- **Safety or operator faults** — Aborts the run. Resume the sequence.

Restarting An Interrupted Sequence

To restart an aborted sequence from the point of interruption:

1. Resolve the problem that caused the interruption.
2. Identify the last sample vial that was run successfully. (Check the vial number of the last successful chromatogram.)
3. Assign the first sample vial run to be the vial number after the last successful one.
4. Start the revised sequence from your controlling device. (The Agilent ChemStation allows you to run a partial sequence to keep the original sample numbers.)

Following an interrupted sequence, the tray will try to return a vial it was holding in its gripper arm to its proper tray position before beginning or resuming the sequence. Occasionally, you may need to manually return the vial to the tray before the sequence will start.

Running A Priority Sample

If the *Use priority* parameter is *on* in your 6890 GC sequence, 7683 Automatic Liquid Sampler tray gripper checks for a vial in position 100 before loading each new vial into the injector turret. If it finds a vial there, it will load that sample vial into the turret and run it according to the method you assigned for priority samples. When the priority sample run is completed, it will return the priority sample vial to tray position 99. The tray gripper will again check vial position 100, and if there is no vial there, your original sequence will continue from where it was interrupted. For more information on how to program a priority sequence, see your 6890 Plus GC documentation.

Preparing Sample Vials

Selecting Sample Vials

The 7683 Automatic Liquid Sampler injector and the tray use clear or amber glass sample vials with crimp caps, or Target[®] DP[™] screw-cap vials. Use amber glass vials for light-sensitive samples. Refer to your Agilent catalog for consumables and supplies for acceptable vial types. Incompatible sample vials cause tray and turret errors.

Figure 2 shows the critical dimensions for sample vials and microvial inserts to be used with the 7683 Automatic Liquid Sampler. These dimensions do not make up a complete set of specifications.

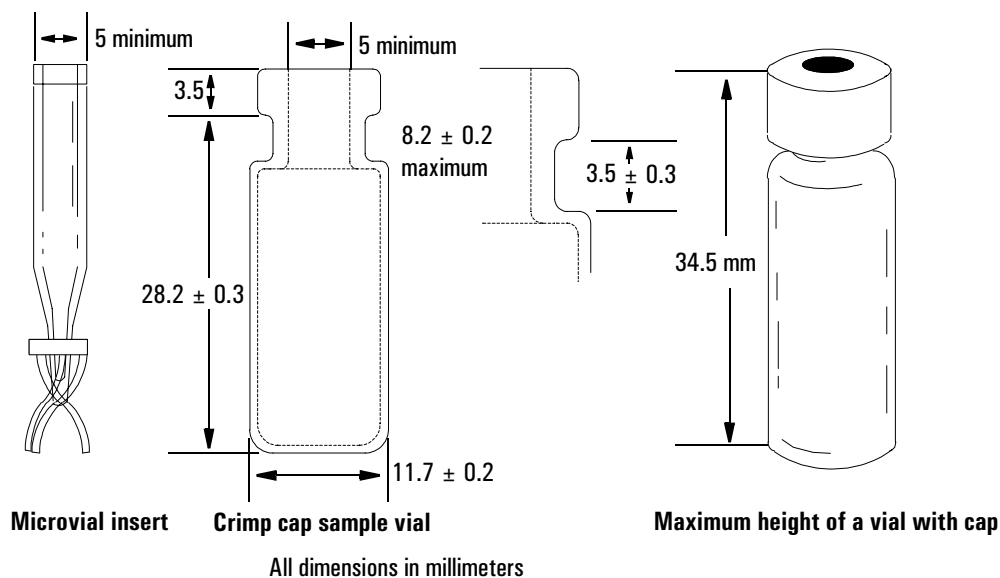

Figure 2 Dimensions for sample vials and microvial inserts

Labeling Sample Vials

Vials are available with a write-on spot for easy marking. If you choose to make and apply your own labels, Agilent Technologies, Inc. recommends the positioning and maximum label thickness shown in Figure 3.

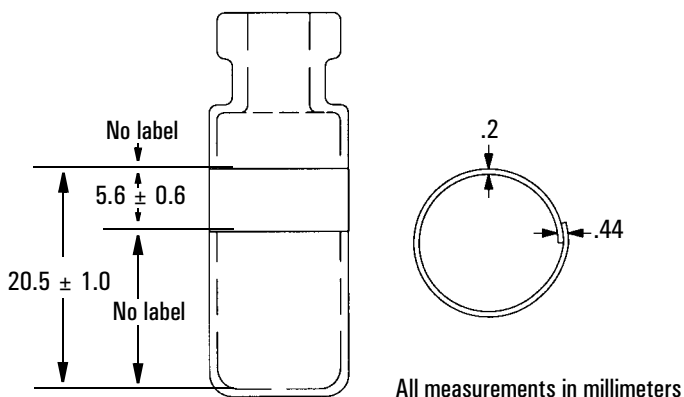

Figure 3 Label specifications

Caution

Correct sample vial dimensions are critical for proper tray gripper operation. Vials and labels that do not meet these specifications may cause sampler errors. Service calls and repairs found to be due to vials and microvials that do not meet these specifications are not covered under warranty or the service contract.

Sample Vial Septa

There are 2 types of septa used with crimp caps and screw-on caps, each with different resealing characteristics and different resistance to solvents.

- One type is natural rubber formulation coated with Teflon on the sample side. This septa is suitable for samples with a pH range of 4.0 to 7.5. It is less resistant to solvents after puncture, and is more easily cored than silicone rubber. Coring may deposit septum pieces in the vial and affect your chromatograms.

- Another is high-quality, low-extractable silicone rubber septa, coated with Teflon on one or both sides. This is more resistant to solvents after puncture and to coring by the needle.

Refer to your Agilent catalog for consumables and supplies for more information.

Figure 4 shows the diameter for vial cap apertures.

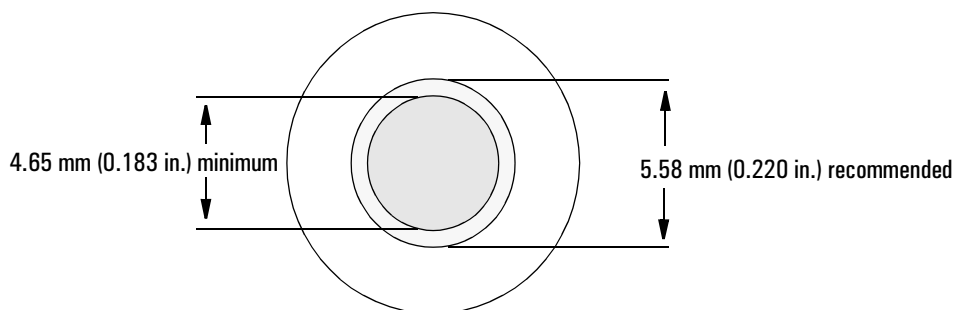

Figure 4 Vial cap aperture specifications

Filling Sample Vials

Recommended fill volumes are:

- 1 mL for the 2 mL vial
- 50 μ L for the 100 μ L vial

Refer to your *Sampling Techniques Handbook* for more information on sample vial volumes and how it can effect chromatographic results.

If You Do Not Use The Optional 100-vial Tray

You can place one vial in the standard injector turret, or you can place up to three vials in it by installing optional inserts (part no. 07673-40150). If you use the eight sample position turret, you can place up to 8 sample vials in it. See Figure 5.

Operation Guide
Preparing Sample Vials

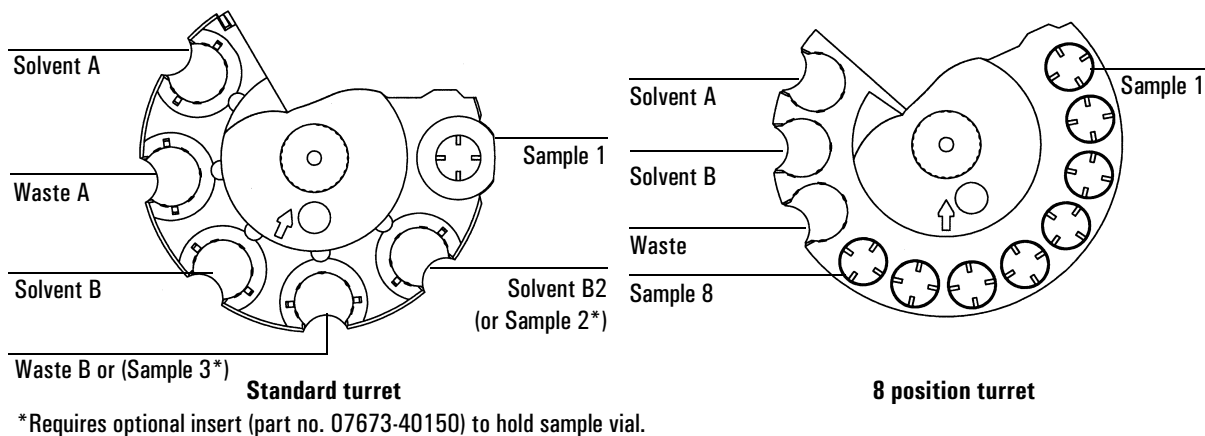

Figure 5 Vial placement in the turret

If You Use The Optional 100-vial Tray

You must use the standard turret. You may place up to 100 samples in the four-tray quadrant, according to the programmed sequence. Figure 6 shows sample vials placed in a tray for a sequence that uses tray positions 6 through 21.

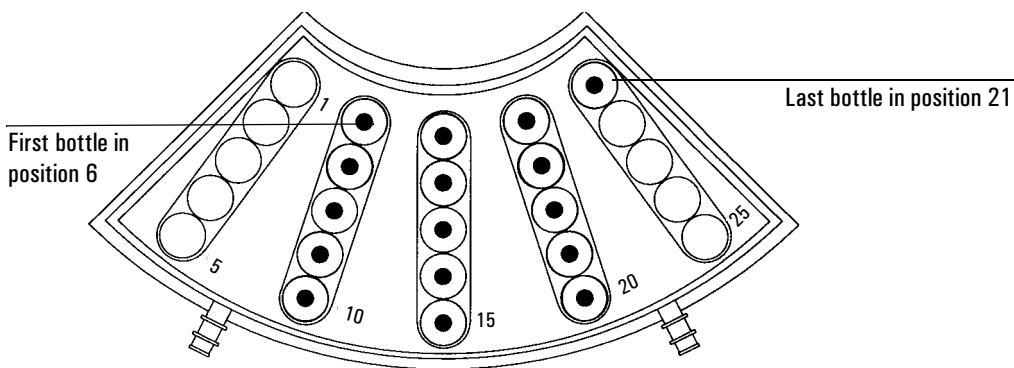

Figure 6 Loading tray positions

Preparing The Solvent And Waste Bottles

Solvent bottles hold solvent for rinsing the syringe between injections. The injector discards the solvent washes and sample washes into waste bottles. The number of samples that can be analyzed may be limited by the wash or waste bottle capacity shown in Figure 7 and Figure 8.

Rinse and fill each solvent bottle with 4 to 4.5 mL of fresh solvent. The liquid level will be near the shoulder of the bottle. Good laboratory practice dictates using no more than 2.0 mL of the 4.5 mL solvent for syringe washes. The needle tip draws solvent at a height of 18.5 mm from the bottom of the vial. See Figure 7.

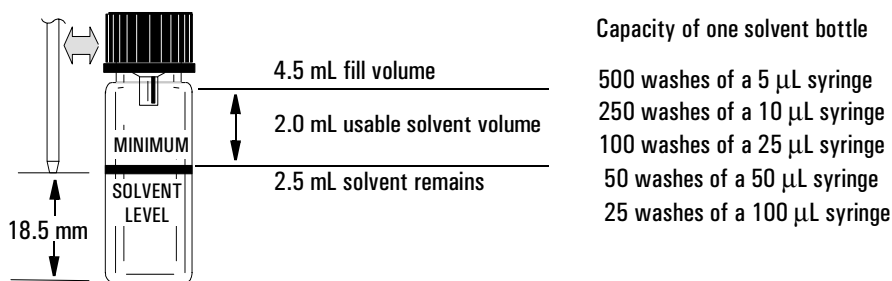

Figure 7 Position of syringe tip when withdrawing solvent

Empty and rinse each waste bottle after each multiple vial run. The syringe can discard about 4 mL of waste into the waste bottle. See Figure 8.

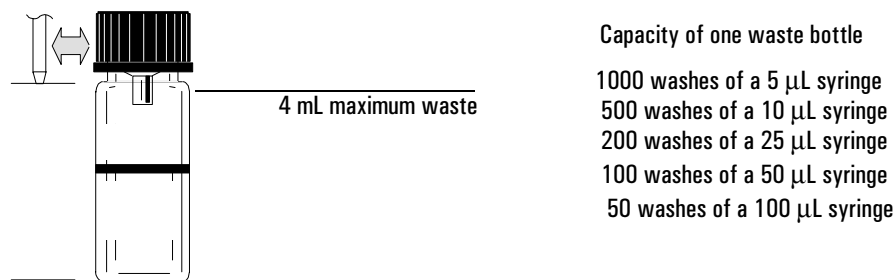

Figure 8 Position of syringe tip when discarding waste

Using Two Injectors

With two injectors mounted on the GC, you can use the front injector or the back injector or both injectors simultaneously.

Two-injector configurations have the following characteristics:

- The system sends one **injector ready** signal to the GC when *both* injectors are ready and one **start** signal at the beginning of the injection stroke.
- The two injectors inject simultaneously.

With A Tray

Set run parameters for each injector in the sequence. When you set up the run parameters, you must identify which data channel is for which injector.

- When using an 6890 Series GC for sampler control, you assign the channel when you set up the sequence.
- When using the Agilent ChemStation for sampler control, you assign the channel when defining the instruments.
- When using the 3396/3397 Integrator (INET) for sampler control, you assign the channel when you set up the run parameters for the second injector.

When both injectors have samples, they begin the injection cycle together, including any sample washes. After they have completed the specified sampling steps, they inject the samples. After the injection, both injectors go through the solvent wash cycle. When both injectors are done, the tray picks up the sample vial from the front injector and returns it to its original position on the tray, then picks up the vial from the back injector and returns it to its original position.

Without A Tray

The injectors go through the same motions as with a tray. The injectors inject samples from position 1 first, followed by samples from the remaining sample vial positions. If the two injectors do not have the same number of samples, the injector that completes its sequence first remains idle while the other finishes.

Syringes

Inspecting A Syringe

Before installing a syringe:

1. Roll the syringe on the edge of a clean flat surface. If the tip of the needle moves in a circle, straighten the shaft by bending it slightly near where it connects to the syringe barrel and check it again. See Figure 9.

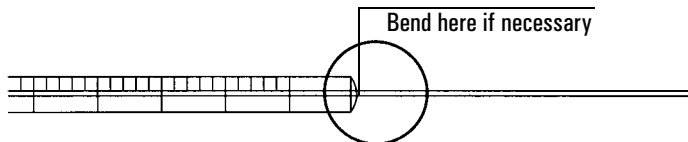

Figure 9 Syringe needle inspection

2. Check for a rough needle. The needle surface may have closely spaced concentric ridges that act like a miniature file and abrade pieces of the septum into the inlet or vial. The ridges are easy to see under 10X magnification.

If there are ridges, polish the needle by pulling it through a folded piece of fine emery paper between your finger and thumb until the ridges are gone. Be careful not to modify the tip of the syringe.

3. Check for a sticky plunger. Slide the plunger of the syringe up and down a few times. It should move smoothly—without sticking or binding. If it is sticky, remove the plunger, and clean it with solvent. For more information, see your *Sampling Techniques Handbook*.

Installing A Syringe

To install a syringe:

1. Disconnect the injector cable from the GC and lay the injector on its back on a flat surface.
2. Open the injector door.
3. Slide the syringe carriage up (or down) until the syringe is accessible. See Figure 10.
4. Pass the syringe needle through the hole in the needle support foot.
5. Align the syringe barrel with the flange guide and syringe clip and press the syringe into place, keeping the needle in the hole of the needle support foot.
6. Close the syringe latch by swinging it clockwise.

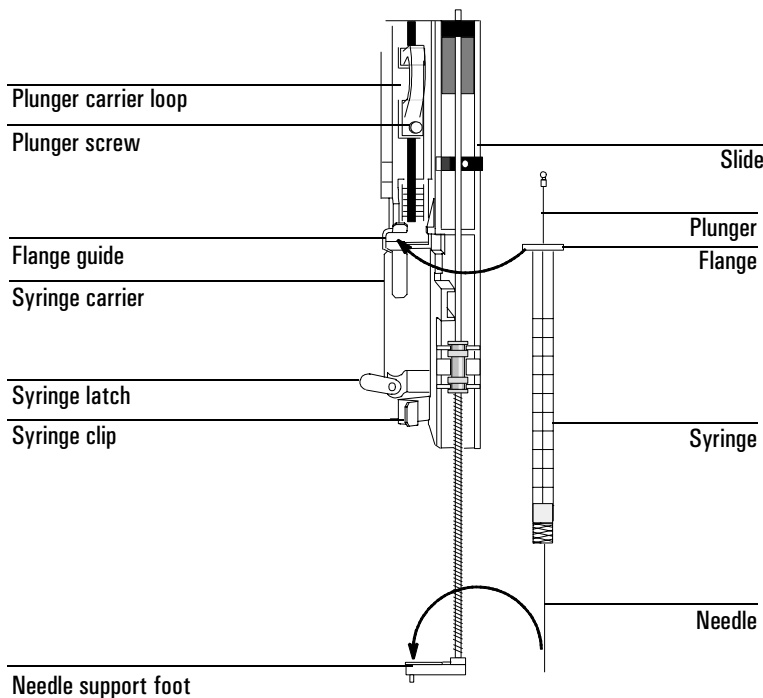

Figure 10 Installing the syringe

7. Move the plunger carrier loop down and tighten the plunger screw.
8. Move the plunger carrier loop up and down. If the syringe plunger does not move along with the carrier, repeat the previous steps. Be sure the plunger screw is tight.
9. Check that the needle is aligned with the needle guide in the foot by moving the slide up and down. The needle should slide smoothly in the needle guide. See Figure 11.

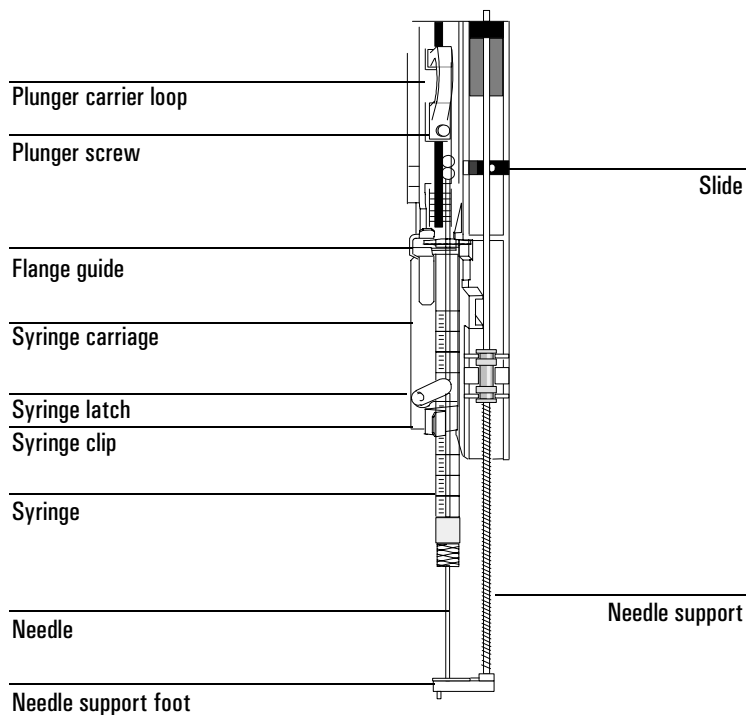

Figure 11 Syringe carriage and needle support with needle installed

Caution

Do not operate the injector without a syringe in place because the syringe latch may interfere with the motor if it is allowed to swing freely.

10. Pull down the syringe carriage until the needle tip is near the top of the inlet septum nut.

The needle should be centered exactly over the hole in the septum retainer nut. Make sure the needle will hit the septum without rubbing on the nut.

11. If the needle is not centered over the septum retainer nut, check that the syringe is installed correctly in the syringe carrier, the syringe needle is straight, and the needle support assembly is properly installed.

Removing A Syringe

1. Disconnect the injector cable from the GC and lay the injector on its back on a flat surface.
2. Loosen the plunger screw and raise the plunger carrier loop off the syringe.
3. Open the syringe latch.

Caution

Be careful not to bend the syringe needle. Only pull the syringe out of the carriage until clear. The needle bends easily when still seated in the needle support.

4. Carefully lift the syringe flange out of the flange guide until clear, then lift the syringe needle out of the needle support.

Cool On-column Injection

For an 6890 GC with a cool on-column inlet, the 7683 Automatic Liquid Sampler can perform injections directly onto 250- μm , 320- μm , and 530- μm columns. For a list of consumables needed to perform these injections, see Volume 2 of your GC Operating Manual.

When performing cool on-column injections, the injector:

- Slows the carriage speed so the overall injection time increases to 500 milliseconds.
- Lowers the tip of the syringe needle an additional 19 mm onto the column.

If you need to adapt your injector for cool on-column injection, change the inlet column size, or change the septum nut or cool on-column insert, refer to your Agilent 7683 *Installation Guide* and to your Agilent 6890 GC Operating Manual, Volume 2, Inlets.

Controlling Sample Vial Temperatures

This section explains how to connect tubing to the tray quadrants, how to determine the water bath temperature needed to obtain an approximate sample vial temperature, and the pressure limitations of the quadrants.

This section does not explain how to set up a water bath and pump.

You can control the temperature of the sample vials in the tray by:

- Pumping a temperature-controlled liquid through the tray quadrants.
- Freezing an ethylene glycol and water solution inside the tray quadrants.

The quadrants are designed for low flow rates, low pressures, and long temperature equalization times. If you freeze an ethylene glycol or alcohol solution in the quadrants, fill the quadrants to less than 90% of their total capacity.

Caution

Ensure that the drainage tube is attached to the base of the tray and remove any equipment from underneath the tray. When controlling for a low sample temperature with a high ambient temperature or high humidity, water condensation from the quadrants and tray could damage equipment under the tray.

Connect the tray quadrants

1. Connect a piece of 1/4-inch id (6.35 mm) tubing from the drain fitting on the tray to waste.
2. Connect the tray quadrants together using 1/4-inch id (6.35 mm) tubing as shown in Figure 12.

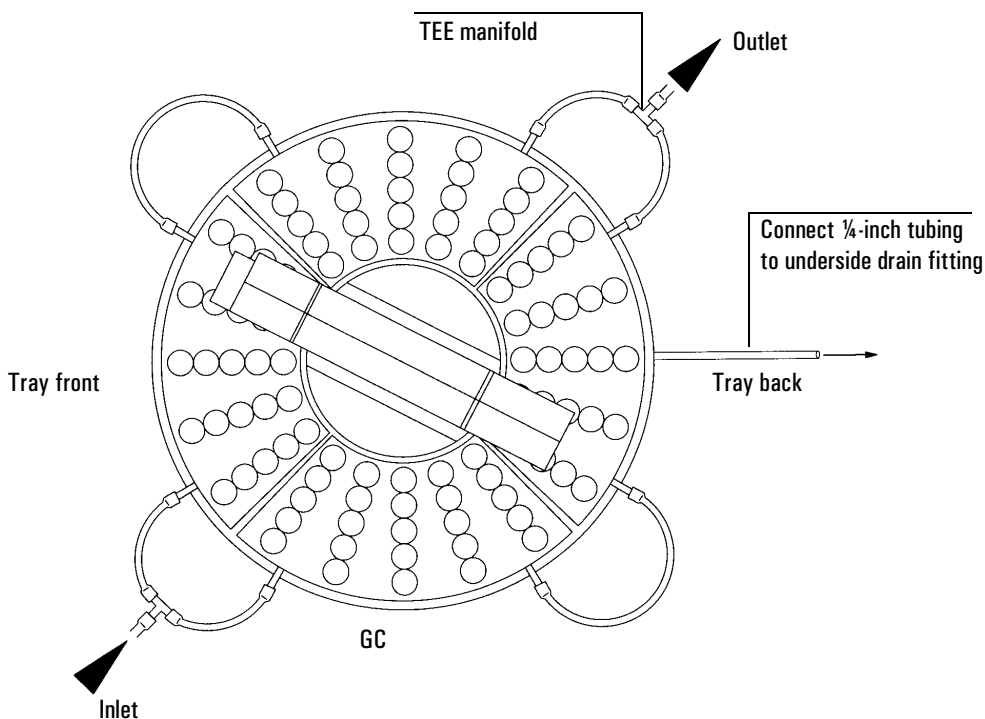

Figure 12 Tray quadrant plumbing

Determine the water bath temperature

The temperature of the sample vials depends on several factors, including the ambient temperature of the air around the tray and the temperature of the water bath.

Caution

If the sample temperature is critical for accuracy, experiments should be performed to validate water bath settings. Actual heat transfer varies with vial material, humidity, condensation on the vial, and flow rates.

Use the chart in Figure 13 to determine the water bath temperature.

Operation Guide
Controlling Sample Vial Temperatures

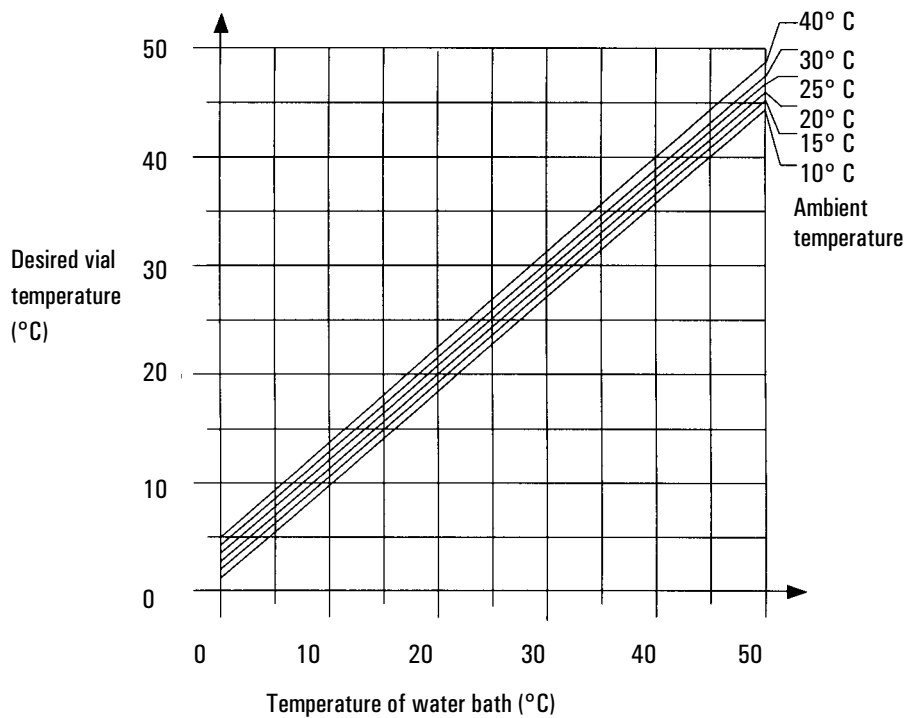

Figure 13 Sample vial temperature versus water bath temperature for values of ambient air temperature

Tray quadrant temperatures and pressures

Do not allow the tray inlet pressure and inlet temperature to exceed the limits shown in Figure 14. If you operate the bath outside this range, the quadrants could be damaged.

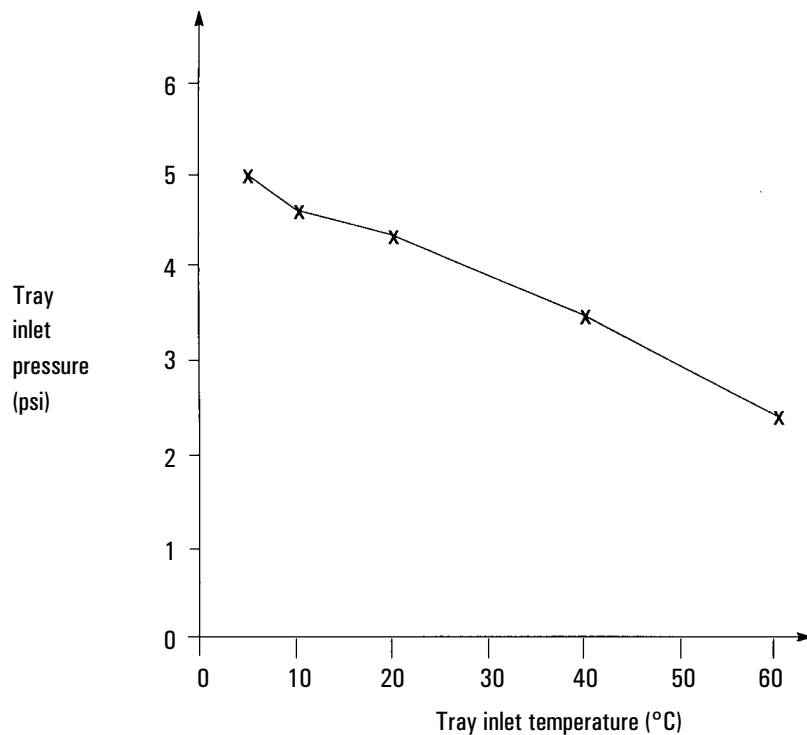

Figure 14 Maximum tray inlet pressures and temperatures

Water bath and pump specifications

The water bath and pump system used to control the sample vial temperatures must meet these specifications.

- The components must meet national standards for safety requirements, be suitable for unattended operation, be suitable for continuous operation, and be controllable for high-temperature protection.
- The minimum cooling power required for the water bath is 100 W at bath temperatures of 5°C.
- If you use a built-in pump, it must be suitable for external circulation of liquid and for connection of 1/4-in. id (6.35 mm) tubing.
- If you use a pressure pump, it must maintain a pressure between 1.5 and 2.5 psi.
- If you use a suction pump, the pump vacuum cannot exceed -4 psi.

Coolant

Use distilled water as your cooling fluid. If desired, you may add a maximum of 3% ethylene glycol to the distilled water to prevent freezing.