

Agilent Technologies

Innovating the HP Way

Chemical Analysis Group

5890 Gas Chromatograph

5890 - Common Cabling \ Pin-outs
Document A15707

- 310 Standalone Cable Configuration
- 320 HP 5890/Data System Cabling Diagrams
- 330 HP 5880/Data System Cabling Diagrams
- 340 HP 6890/Data System Cabling Diagrams

Configuration and Cabling

Standalone Cable Configuration for 18594A/B Controllers

310

Figure 310-1 5890 remote connector

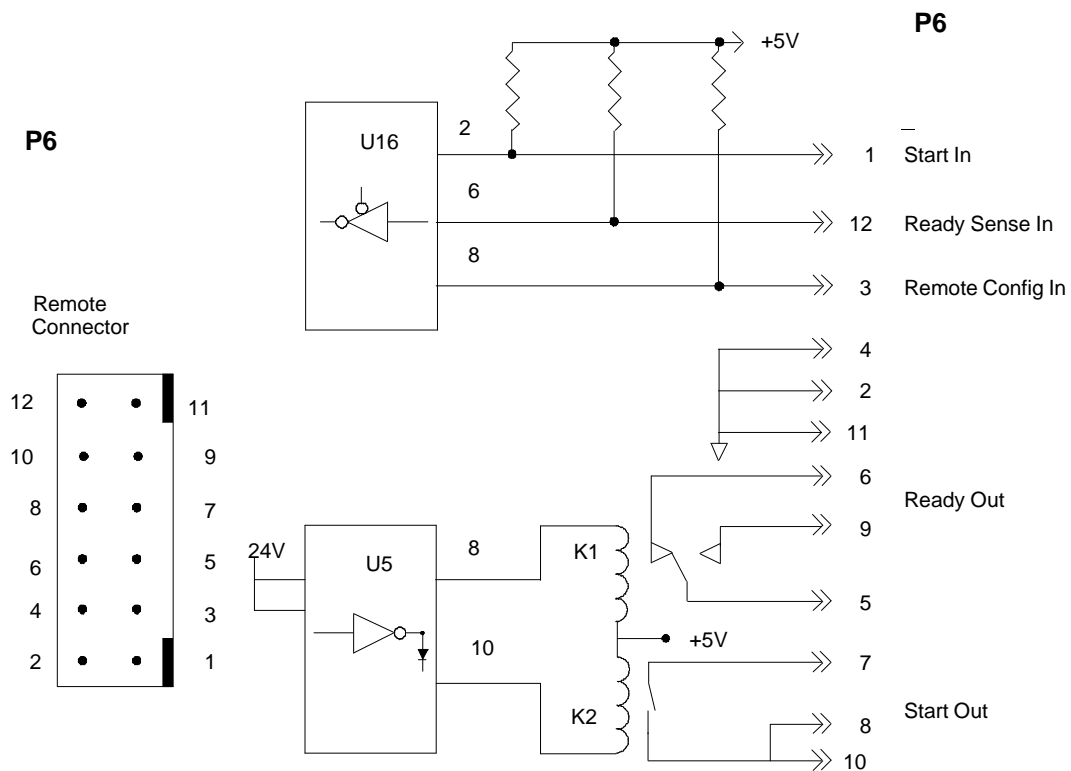

Pin #	Signal Description
1	Remote Start In - "TTL" Input: expects a pulse input of greater than 5 msec from pin 1 to any ground pin.
2	Ground
3	Remote Config In - "TTL" Input: expects a contact closure or a jumper from pin 3 to any ground pin. When pin 3 is grounded a run can not be started by pressing START on the GC. It is waiting for a start pulse on pin 1. When using an Automatic Liquid Sampler pressing START on the GC causes the sequence to start. The run is started when the injection is made.
4	Ground
5 & 6 or 5 & 9	Ready Out - Two sides of a single pole, double-throw relay. When 5890 is ready then the contacts connected to 5 & 6 open. Also when 5890 is ready the contacts connected to pins 5 & 9 are closed.
7 & 8	Start Out - Two sides of a normally-open relay. Contacts are closed for 50 msec to signal the start of a run. If pin 3 is connected to ground then the contacts are closed when the oven program starts.
10	Same as pin 8.
11	Ground
12	Remote Ready In - "TTL" input. Expects to be connected to any ground pin by an external device if that device is "Not Ready."

Figure 310-2. Using the parallel remote PC board.

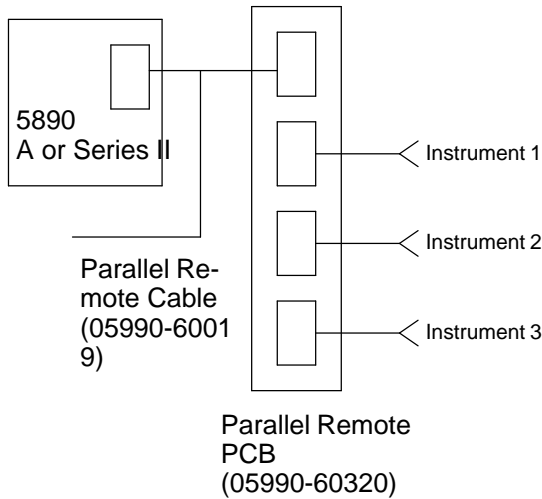

When connecting multiple instruments to the 5890 remote connector there are TWO main causes for running into trouble. They are the following:

#1

The instruments connecting to the remote connector must use the same polarity on the remote connection (+ and -). Even when using all HP cables, the connections need to be converted so that the instrument inputs and outputs (+ and ground connections) are the same.

#2

When using multiple instruments, it is important to be aware of which instrument is starting the run. In the case where an Automatic Liquid Sampler is being used as one of the instruments, the sampler will send the start between pin 1 and the ground of the 5890. The other instruments to be started also need to be connected to those same pins on the parallel remote PC board.

Example:

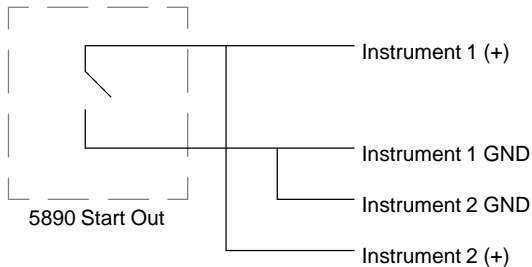

Asynchronous standalone cable configuration for HP G1512A controllers

When configured for asynchronous standalone mode, the APG remote connector is redefined to provide independent start, stop, and readiness signals for each injector. General-purpose cables with spade lugs and a terminal block can be used to connect the output to an HP 35900C/D/E analog-to-digital (A/D) convertor configured for asynchronous operation.

Figure 310-3. Typical asynchronous cable configuration.

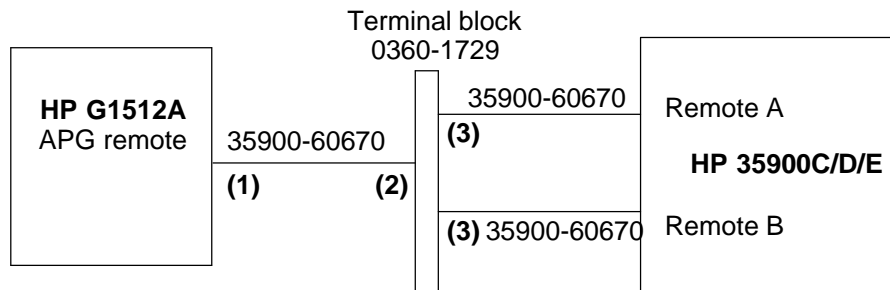

PIN #	Function	Color code	Color code
1	GND	black	black (remote A&B)
2	Front injector ready in	white	orange (remote A)
3	Back injector ready in	red	orange (remote B)
4	Front injector ready out	green	NC
5	Back injector ready out	brown	NC
6	Front Start request	blue	violet (remote A)
7	Back Start request	orange	violet (remote B)
8	Front Start out	yellow	red (remote A)
9	Back Start out	violet	red (remote B)

NOTE: (1) The remote connector on the HP G1512A is APG-compatible which means it accepts and outputs TTL levels (0 V low, +5 V high) rather than contact closures.

(2) This mode is only supported when the GC is in isothermal mode. Typically this means that the GC would not have to be started and, therefore, would require no cabling.

Figure 320-1. HP 339x INET integrator.

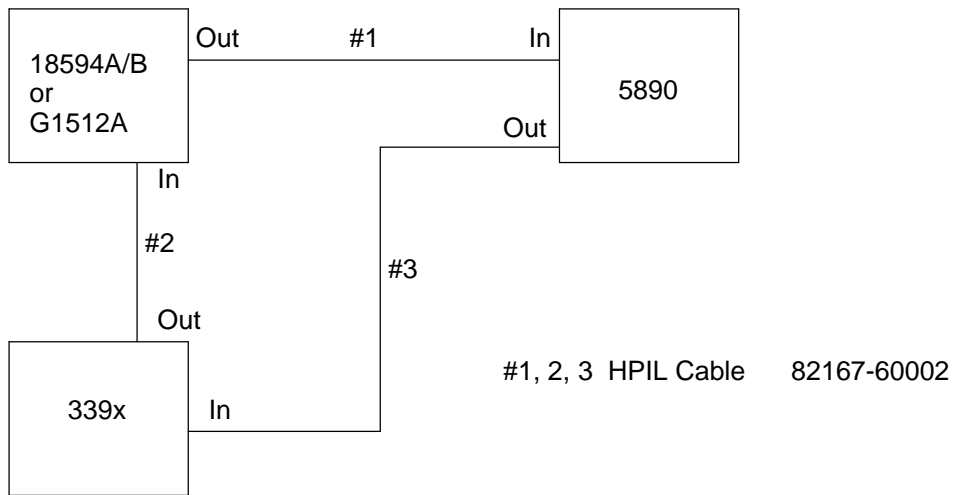

Figure 320-2. HP non-INET integrator.

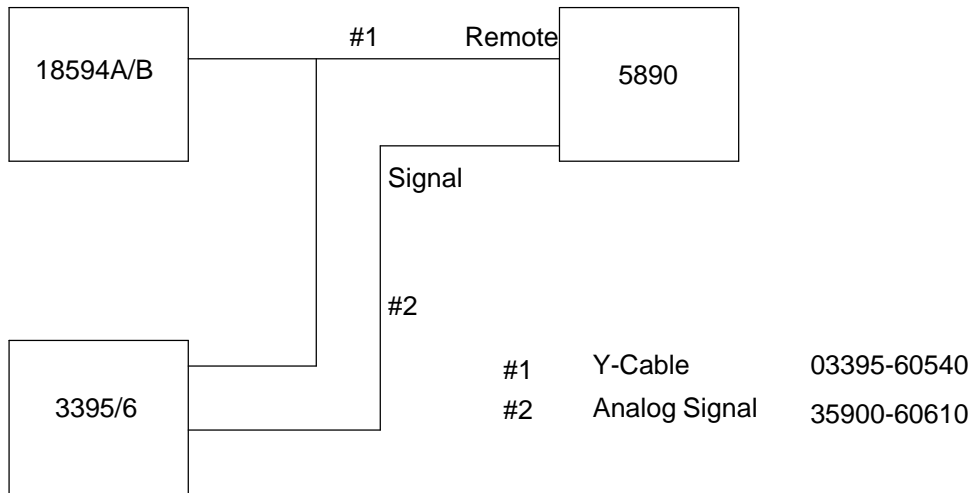

Figure 320-3. HP 3365 ChemStation (DOS).

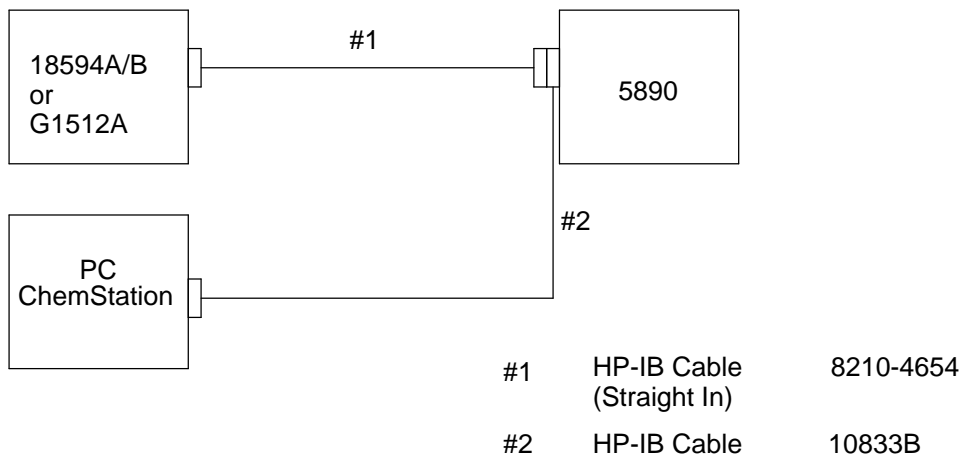

Figure 320-4. HP ChemStation with 18594A/B controller.

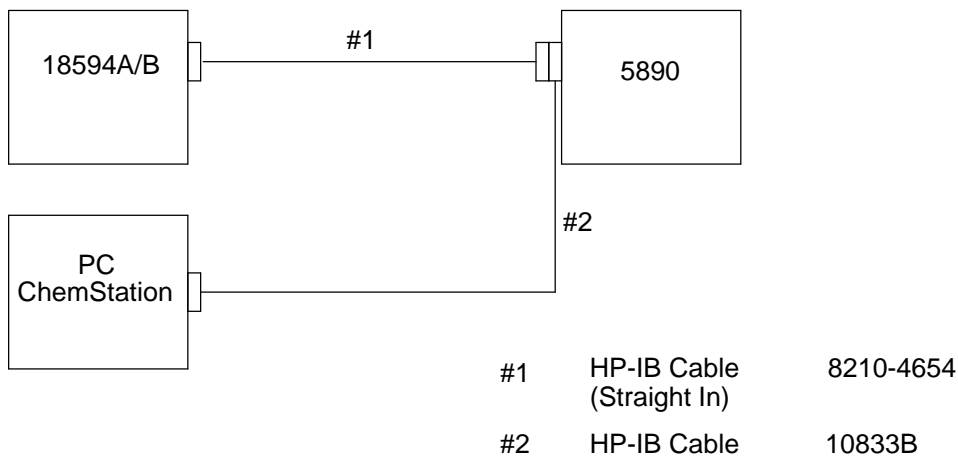

Figure 320-5. HP ChemStation with G1512A controller.

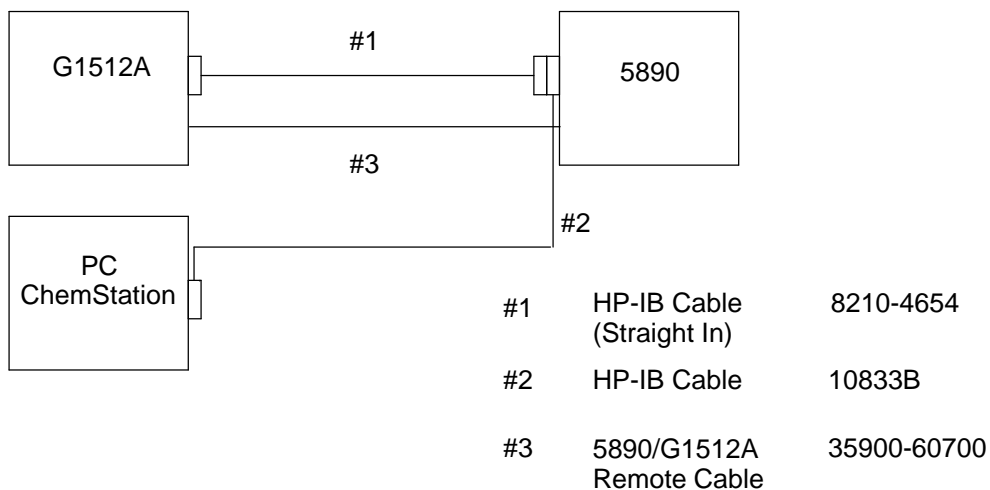

Figure 320-6. HP MSD ChemStation.

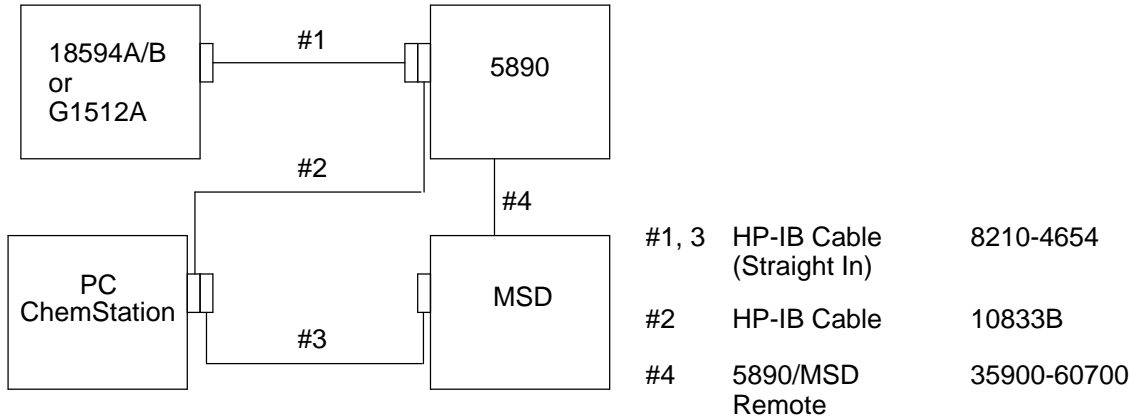

Figure 320-7. Standalone 18594A/B, 5890.

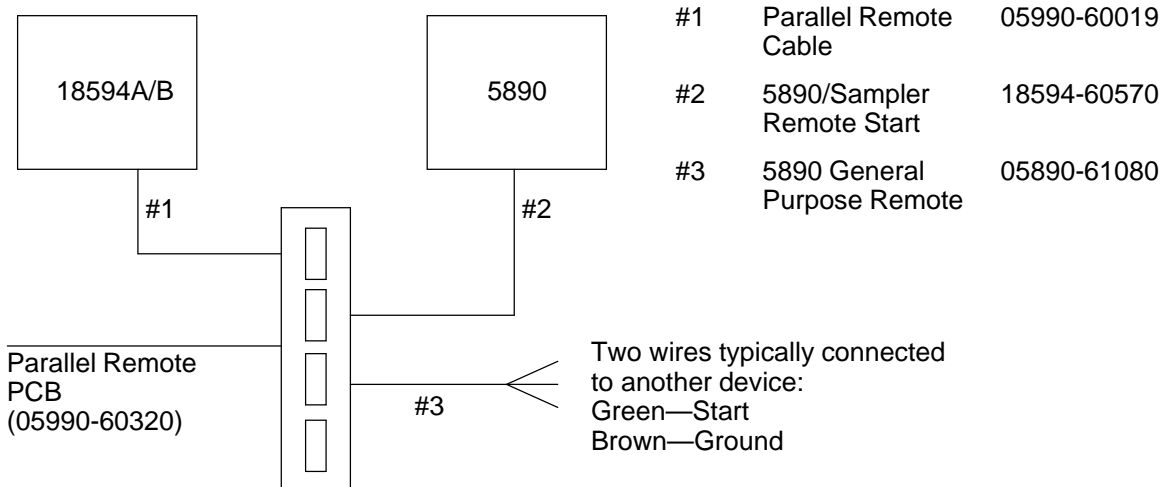

Figure 320-8. Non-HP data system.

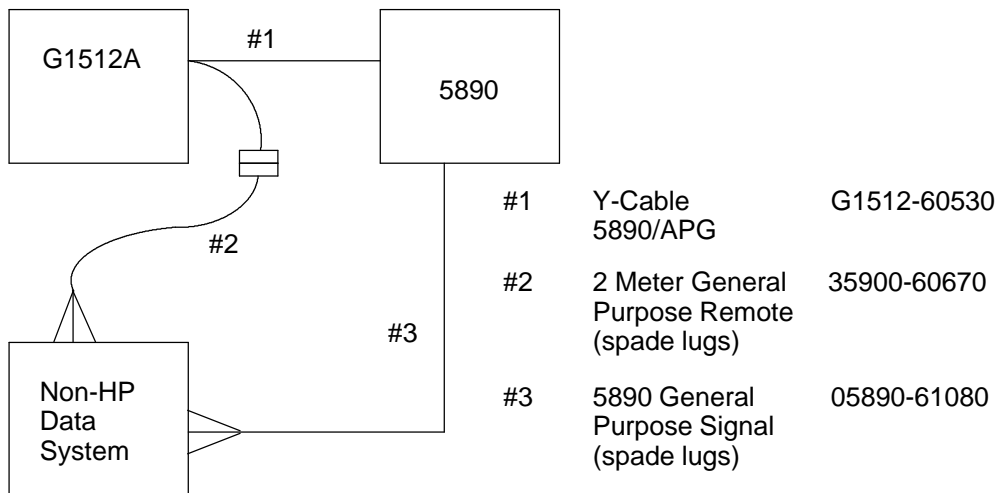

Figure 320-9. HP 35900C/D/E analog-to-digital converter.

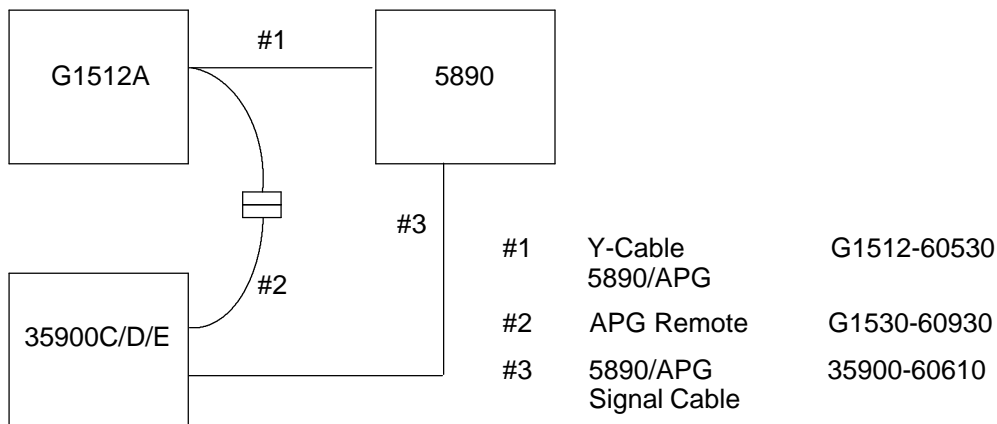
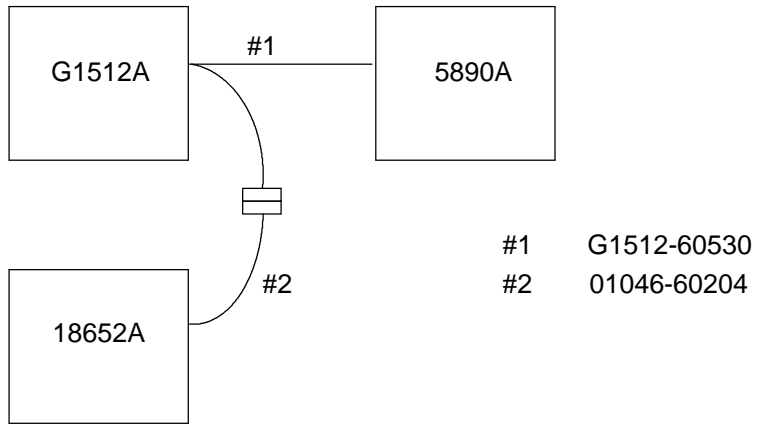

Figure 320-10. G1512A HP 5890A with 18652A A/D box



HP 5880/Data System Cabling Diagrams

330

Figure 330-1

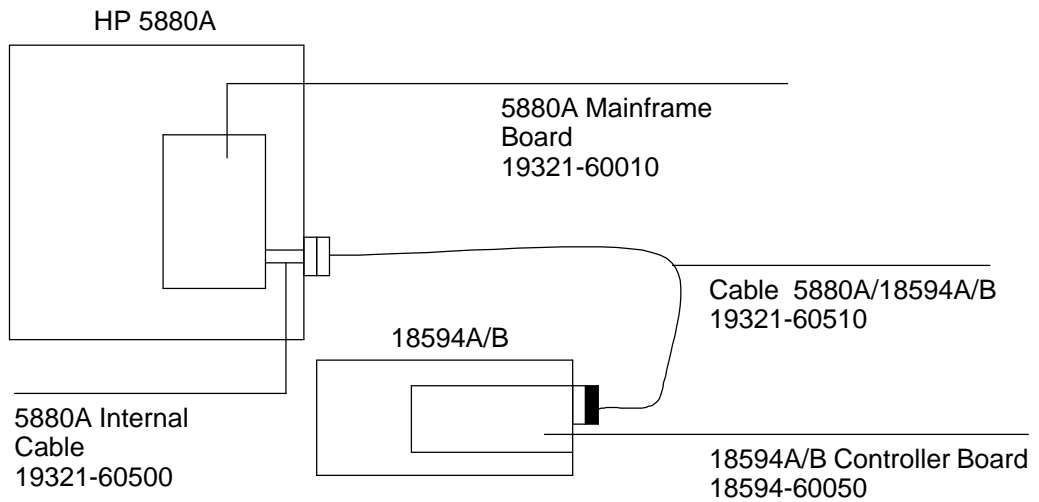

HP 6890 GC-G1512A

Figure 340-1. G1512A to HP 6890 gas chromatograph

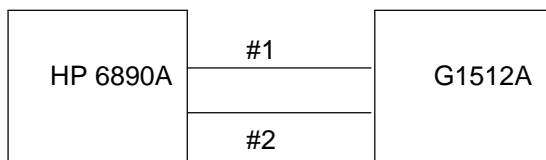

- #1 RS232 cable G1530-60600
- #2 APG remote cable 2M
G1530-60930

HP 6890 GC-GC ChemStation-GC Automatic Liquid Sampler (ALS)

Figure 340-2.

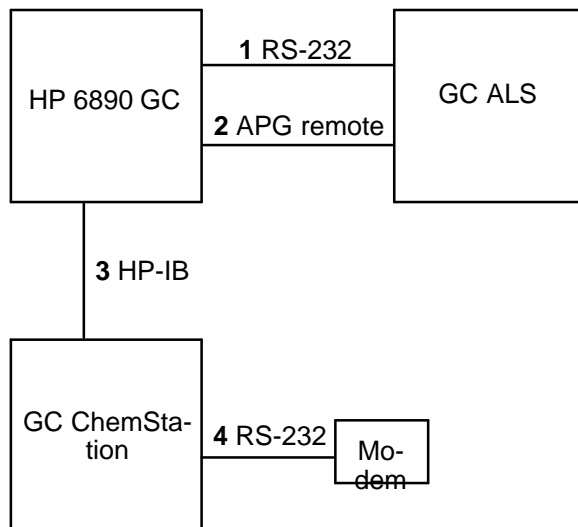

Number	HP part no. and description
1	G1530-60600, RS-232 cable, 9-pin female/9-pin female
2	G1530-60930, APG remote cable, 2-m, 9-pin male/9-pin male
3	8120-3446, 2-m HP-IB cable
4	HP 24542M (also 24540-80012), RS-232 cable

HP 6890 GC-HP Mass Selective Detector-GC ChemStation-GC ALS

Figure 340-3.

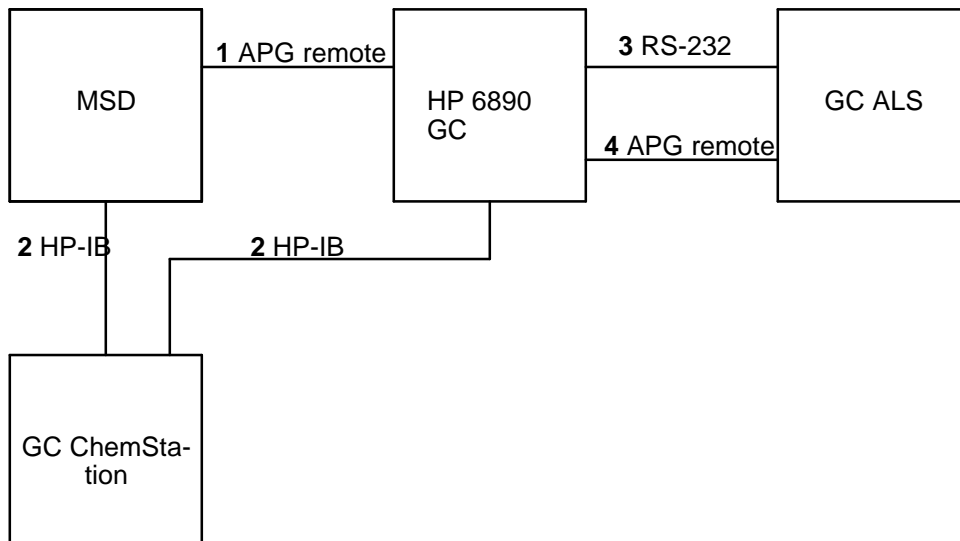

Number	HP part no. and description
1	G1530-60930, APG remote cable, 2-m, 9-pin male/9-pin male
2	8120-3446, 2-m HP-IB cable
3	G1530-60600, RS-232 cable, 2-m, 9-pin female/9-pin female
4	G1530-60930, APG remote cable, 2-m, 9-pin male/9-pin male

HP 6890 GC-GC ALS-Non-HP Data System

Figure 340-4.

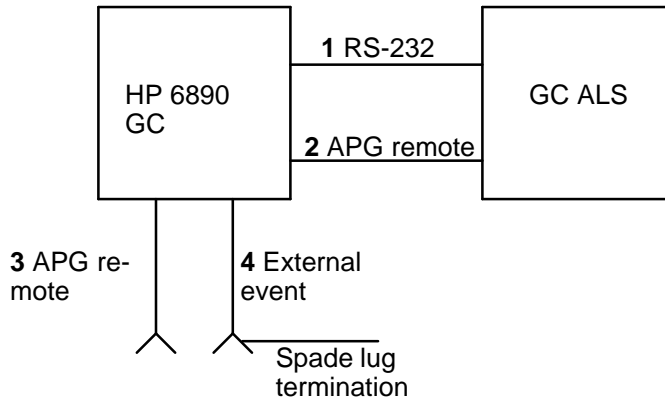

Number	HP part no. and description
1	G1530-60600, 2-m RS-232 cable, 9-pin female/9-pin female
2	G1530-60930, 2-m APG remote cable, 9-pin male/9-pin male
3	35900-60670, General use APG remote cable, 9-pin male/spade lugs
4	G1530-60590, External event cable, 8-pin/spade lugs

HP 35900-60670 APG remote cable spade lug identification

Connector 1	Signal	Connector 2	Signal
9 pin (male)	name	spade lugs	
1	GND	Black	
2	Prepare	White	
3	Start	Red	
4	Shut down	Green	
5	Reserved	Brown	
6	Power on	Blue	
7	Ready	Orange	
8	Stop	Yellow	
9	Start Request	Violet	

HP G1530-60590 external event cable spade lug identification

Pin	Color	Signal
1	Yellow	24 V Out 1
2	Black	24 V Out 2
3	Red	Ground
4	White	Ground
5	Orange	Contact 1
6	Green	Contact 1
7	Brown	Contact 2
8	Blue	Contact 2

HP 6890 GC-HP 3396B/C or HP 3397A Integrator-GC ALS-Modem

Figure 340-5.

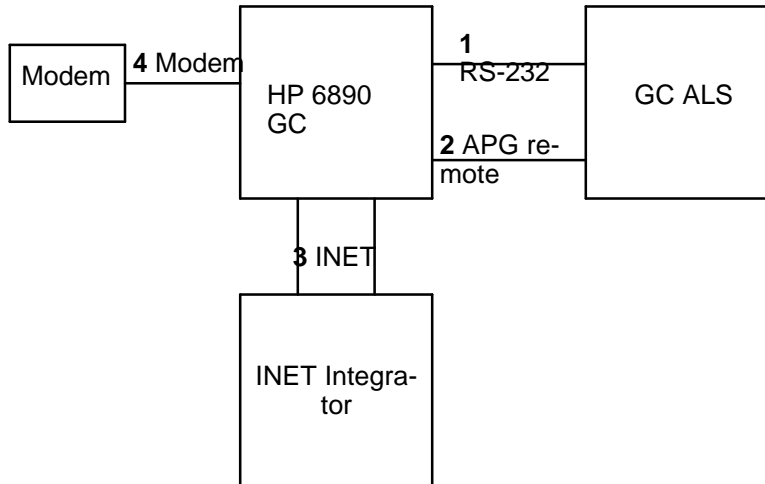

Number	HP part no. and description
1	G1530-60600, 2-m RS-232 cable, 9-pin female/9-pin female
2	G1530-60930, 2-m APG remote cable, 9-pin male/9-pin male
3	Two 82167-60003, 5-m INET cables
4	G1530-61120, Modem cable, 9-pin female/9-pin male OR 24540-80012 (also HP 24542M), Modem cable 9-pin female/25-pin male

HP 6890 GC-HP 3395A/3396B Integrator-GC ALS

Figure 340-6.

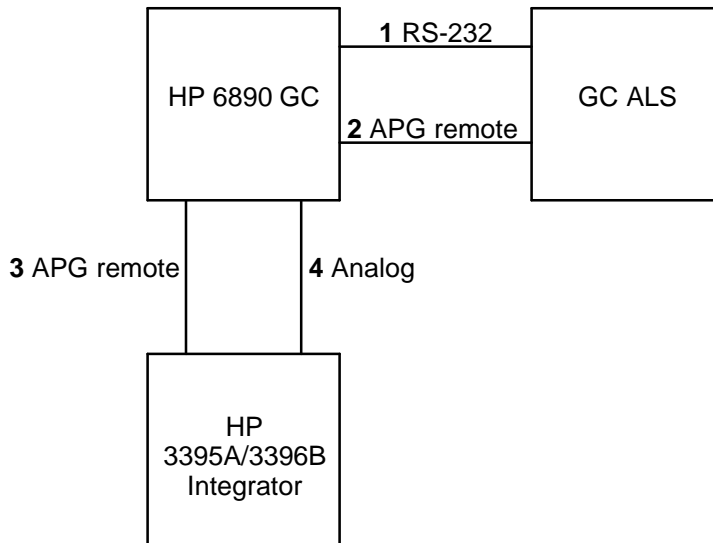

Number	HP part no. and description
1	G1530-60600, 2-m RS-232 cable, 9-pin female/9-pin female
2	G1530-60930, 2-m APG remote cable, 9-pin male/9-pin male
3	03396-61020, APG remote cable, 9-pin/15-pin
4	G1530-60570, Analog cable, 2 m, 6-pin

HP 6890 GC-HP 3395B/3396C or HP 3397A Integrator-GC ALS

Figure 340-7.

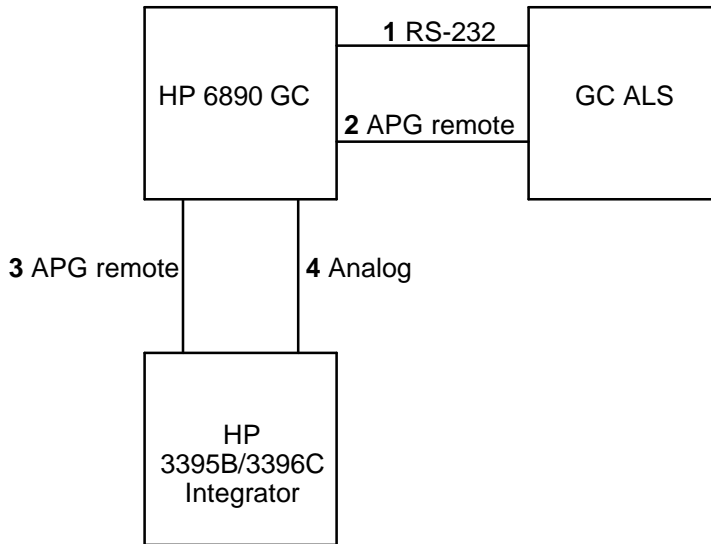

Number	HP part no. and description
1	G1530-60600, 2-m RS-232 cable, 9-pin female/9-pin female
2	G1530-60930, 2-m APG remote cable, 9-pin male/9-pin male
3	03396-61010, APG remote cable, 9-pin/15-pin
4	G1530-60570, Analog cable, 2 m, 6-pin

HP 6890 GC-HP 35900C/D/or E Analog-to-Digital Converter-GC ALS

Figure 340-8.

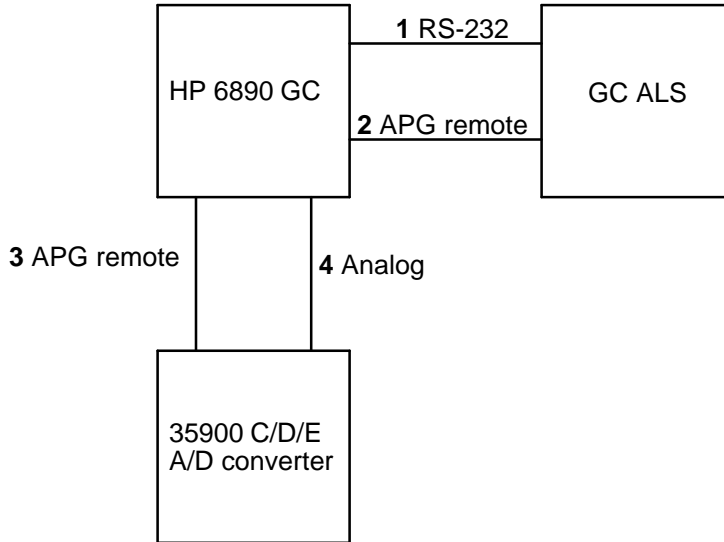

Number	HP part no. and description
1	G1530-60600, 2-m RS-232 cable, 9-pin female/9-pin female
2	G1530-60930, 2-m APG remote cable, 9-pin male/9-pin male
3	G1530-60930, APG remote, 2-m, 9-pin male/9-pin male
4	G1530-60570, Analog cable, 2-m, 6-pin