



Product Data Sheet

Product Name:

Superior Aluminum Square Column Cover
Interior / Exterior Hairline Joints

Distributor:

Columbia Architectural Products, Inc.
10722 Tucker Street
Beltsville, Maryland 20705
phone: (301) 937-4383
fax: (301) 937-6850
web: www.CapIndustriesInc.com

Panel Description:

Our Series "S" Square Column Cover is an extruded aluminum column system. Available 4" x 4" to 16" x 16" (see chart), these multi-part interlocking column cover assemblies allow for a quick and easy installation. Heights range from 8' to 24'.

With your choice of cap and base style, these Column Covers can be used to create a classical look on homes, churches, office buildings, schools, libraries, motels, museums and other public buildings, both interior & exterior applications.

Standard Color Selection:



white almond sandstone tan black*

*only available for 6" and 8" sizes



CAP AND BASE STYLES



CAPS AND BASES



Durability:

Unlike wood, these aluminum columns will not rot, split, warp or weather.

Strength:

Aluminum columns can be used as load bearing structural elements in entrances, covered walkways and balconies, lobbies, colonnades and other structures.

Load Bearing Example:

A 6" x 6" square column that is 12 ft. in length is fully load bearing up to 18,000 lbs.

Square Columns

Dimensions & Load Data

(For Square Fluted, Square Smooth or Square Panel Columns and Caps/Bases)

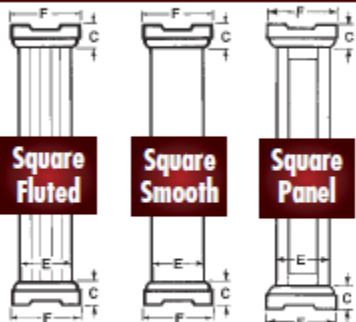

4" columns are available with the Standard cap and base only. All other size columns are available with the Standard, Doric or Charleston cap and the Standard, Doric or Savannah base.

Nominal Width			Actual Width	Caps / Bases (width & height)								Standard Lengths in Ft.	No. Staves Sq. Panel	Load Lbs.			
Square Smooth	Square Fluted	Square Panel		Polymer Composite		Standard		Doric		Charleston					Savannah		
			E	C	F	C	F	C	F	C	F	C	F				
-	4"	-	4	-	-	1 3/8	6	-	-	-	-	-	-	8, 9, 10, & 12'	2	-	12,000
6"	6"	6"	5 1/2	2	8 1/2	2	8 1/2	3 3/4	10 1/2	6 1/2	9 1/4	5 1/4	8	8, 9, 10, & 12'	4	4	12,000
8"	8"	8"	7 1/2	2	10 1/2	2	10 1/2	3 3/4	12 1/2	6 1/2	11 1/4	5 1/4	10	8, 9, 10, 12, & 16'	4	4	18,000
10"	10"	10"	9 1/2	-	-	2 1/2	15	3 3/4	16 1/2	6 1/2	13 1/4	5 1/4	12	8, 9, 10, 12, 16, & 18'	4	4	25,000
12"	12"	12"	11 1/2	-	-	2 1/2	15	3 3/4	16 1/2	10	17 1/4	5 1/4	14	8, 10, 12, 16, 18, & 20'	4	4	27,000
-	16"	16"	15 1/2	-	-	3	20	3 3/4	20 1/2	10	21 1/4	5 1/4	18	12, 16, 18, 20, & 24'	4	8	36,000

Note: All square column staves extend through caps and bases.

Tested lengths are underlined

*Also available in custom colors with minimum order.

