

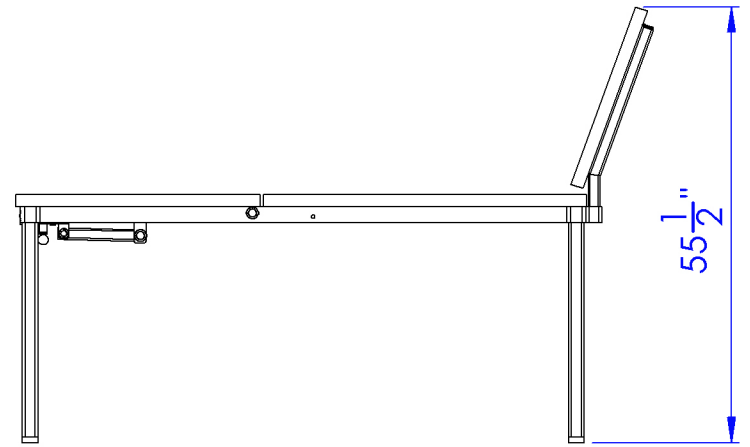

ADJUSTABLE LEG REST PADS

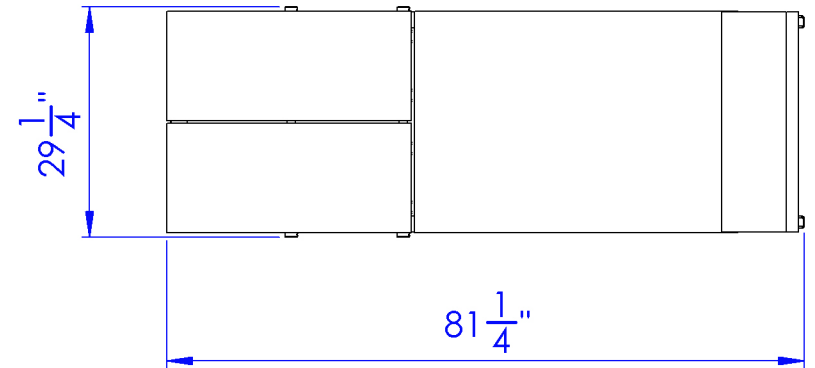

55 1/2"



29 1/4"

81 1/4"

- STEEL**
 - 0.188 WALL (3/16") STEEL ON ALL PRODUCTS
 - 56% THICKER THAN 0.120 AKA 11 GAUGE
- POWDER COATING**
 - HYBRID TEXTURE POWDER COATING FOR INCREASED DURABILITY
- UPHOLSTERY / PADDING**
 - DOUBLE STITCHED SEAMS
 - 3/4" PLYWOOD
 - T-NUT FASTENERS
 - 1" SUPER DENSE CLOSED CELL NEOPRENE PADDING
- STEEL SEALED BALL BEARINGS**
 - PRECISION GROUND STEEL SEALED 1", 1.25", & 1.5"
 - RIDING ON ROCKWALL 60 SHAFTING
- SOLID OAK**
 - 3/4" SOLID TONGUE & GROOVE
- STAINLESS STEEL**
 - ON ALL ADJUSTABLE PARTS
- WEIGHT STACKS**
 - 1" SOLID ROUND GUIDE ROD w/INDUSTRIAL CHROME PLATING
 - 100% STEEL SELECTORIZED WEIGHT STACK PLATES
- CUSTOM COLORS AVAILABLE**
- CUSTOM DESIGNS AVAILABLE**

PRODUCT # AT-TABSPBK
PRODUCT WEIGHT: 257LB
SAMSON EQUIPMENT, INC. 1-800-4-SAMSON SAMSONEQUIPMENT.COM

SPLIT LEG TABLE WITH BACK REST



SAMSON EQUIPMENT
MADE IN AMERICA