



# Coning and Threading Tools for High Pressure Lines

Ranger Manufacturing • 770-536-8031 • [parts@rangermfg.com](mailto:parts@rangermfg.com)

# Power Coning Tools

# Threading Tools

## 1 Tool Kit



## 10 Tool Kit

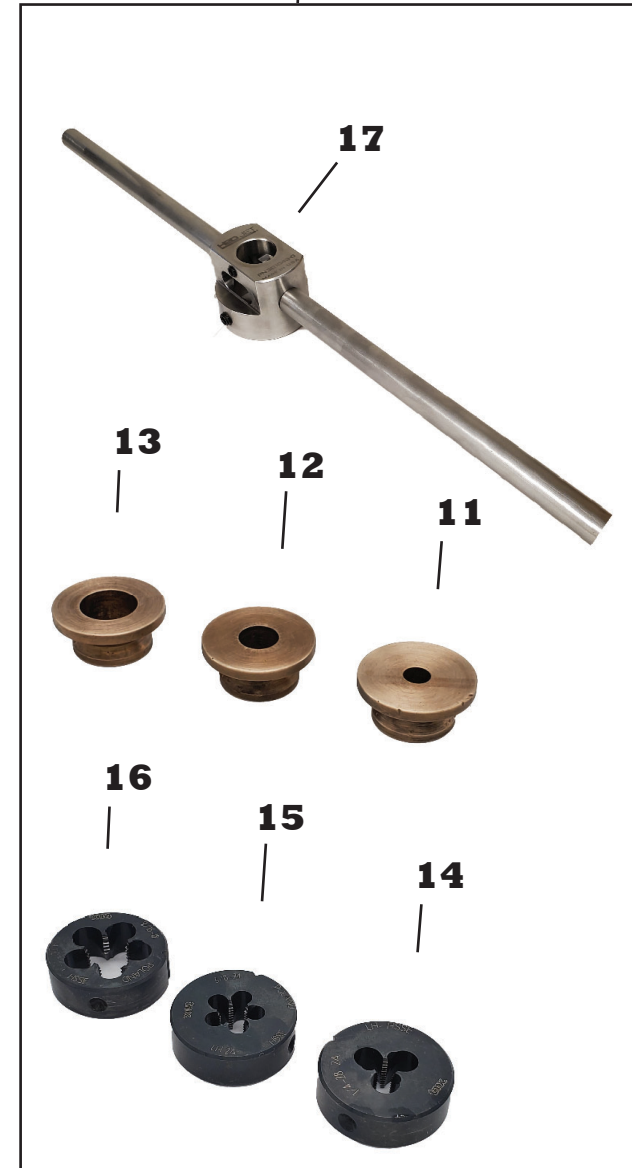

Item	Description	Part Number
1	Tool Kit, Power Coning (includes items 18,2,3,4,5,6,&7)	FP-15-0300
2	Bushing, Power Coning 1/4"	FP-15-0304
3	Bushing, Power Coning 3/8"	FP-15-0305
4	Bushing, Power Coning 9/16"	FP-15-0306
5	Blade, Power Coning 1/4"	FP-15-0301
6	Blade, Power Coning 3/8"	FP-15-0302
7	Blade, Power Coning 9/16"	FP-15-0303
8	Tool, Deburring	FP-15-0309
9	Oil, Coning and Threading	FP-15-0308
10	Tool, Threading (includes items 17, 11, 12, 13, 14, 15, &16)	FP-15-0330
11	Bushing, Threading 1/4"	FP-15-0334
12	Bushing, Threading 3/8"	FP-15-0335
13	Bushing, Threading 9/16"	FP-15-0336
14	Die, Threading 1/4"	FP-15-0331
15	Die, Threading 3/8"	FP-15-0332
16	Die, Threading 9/16"	FP-15-0333
17	Tool, Threading (tool only)	FP-15-0337
18	Tool, Coning Power (tool only)	FP-15-0307



770-536-8031

parts@rangermfg.com

Located just 1 hour Northeast of Atlanta, Ranger Manufacturing is your all in one source for OEM parts. Are you having trouble with your current provider? Long lead times, expensive overseas manufacturer, or just need local guaranteed stock, then Ranger Manufacturing is the shop for you. OEM quality with the pricing and availability you need. Give us a call to discuss your parts needs today!

