

# **WESTERN UNDERGROUND COMMITTEE**

## **GUIDE 2.15** (2.15/00/0588)

### **FLAT SINGLE PHASE TRANSFORMER PADS**

NOTE: This "Guide" summarizes the opinions, recommendations, and practices of the Western Underground Committee members and is issued only to assist these members in preparing their own specifications, or in making recommendations to specification agencies. Thus, this "Guide" may not reflect the complete requirements of each individual utility and is not binding upon them.

#### **1.0 SCOPE**

1.1 This guide provides a standardized method for testing the acceptability of manufactured transformer pads for use with single-phase "mini pad" transformers. Single-phase "mini-pad" transformers shall be defined as transformers meeting the interchangeability dimensions of ANSI C57.12.25, Figure 2.

1.2 This guide does not cover seismic loading conditions, which may need to be considered in the design of foundations used in seismic risk zones.

#### **2.0 GENERAL**

2.1 The purpose of a transformer pad is to support the weight of an oilfilled padmount transformer. The pad must provide a flat surface for placement of the transformer and must transfer and disperse the transformer's weight to the soil. The pad must minimize stresses to cabinet seams, welds, hinges, or latching components due to uneven earth settlement.

2.2 This guide is written for single-phase oil-filled mini-pad transformers. It may or may not be suitable for pads to be used with other type transformers or other equipment.

2.3 This guide is for all fabricated transformer pads (concrete and nonconcrete). Pads may be constructed of plastic, plastic reinforced mortar, fiber reinforced mortar, fiberglass, composite concrete, polymer concrete, or other suitable materials.

2.4 The pad must be inert to its environment. Asphalt-by-asphalt, road salts, fertilizers, transformer oil, other common

chemicals, weather, sunlight, or other reasonable service conditions that it might be exposed to must not affect it.

2.5 The pad must not provide any point for wire entry or circumvention of the Western Underground Guide 2.13 concerning Security of Padmounted Equipment Enclosures.

2.6 For ease of application, transformer pads are referred to by kVA size. It should be recognized that many factors effect transformer size. Some large transformers may be suitable for use on pad 1, listed for transformers 75 kVA and smaller with BIL levels 125 kV or less. A few large 25 kVA, 50 kVA, and 75 kVA transformers may require pad 2 listed for transformers larger than 75 kVA or with BIL levels greater than 125 kV. Pad 3 may be required where special operating procedures require a larger pad.

2.7 These pads shall meet testing requirements as specified; test load magnitudes have been determined for the application of transformers weighting a maximum of:

Pad 1 – 1,600 pounds

Pad 2 – 2,400 pounds

Pad 3 – 2,400 pounds

### **3.0 TESTS**

#### **3.1 Flammability Test**

3.1.1 The finished transformer pad shall not sustain combustion.

3.1.2 Any surface of a finished transformer pad must pass the following test. (The test procedure is an adaptation of the procedure in ASTM D635.)

- a. With the air ports open, adjust the flame of a 10 mm Bunsen or Tirrill burner to produce a blue flame approximately 25 mm high.
- b. Place the burner so the tip of the flame contacts the pad. Apply the flame to the pad for 30 seconds. Upon removing the flame, any burning (flame) or glowing combustion must cease within 60 seconds.

#### **3.2 Chemical Resistance Test**

3.2.1 Samples of all exposed materials of the pad are to be submerged in reagents are to be maintained at 23°C ±2°C.

- a. Sodium Sulphate – 0.1N
- b. Sodium Hydroxide – 0.1N
- c. Sodium Chloride – 5 percent aqueous solution
- d. Calcium Chloride - 5 percent aqueous solution
- e. Calcium Hydroxide - 5 percent aqueous solution
- f. Kerosene – ASTM D543
- g. Transformer Oil – ASTM D543

3.2.2 Samples of all exposed materials of the pad are to be submerged in 1, 1, 1-trichloroethane for five minutes. The reagent is to be maintained at  $23^{\circ}\text{C} \pm 2^{\circ}\text{C}$ .

3.2.3 Immediately following immersion in a reagent for the specified time given in Sections 3.2.1 and 3.2.2, a material sample shall be washed and tested. Any material showing swelling, crazing, blistering, cracking, deformation, erosion, or that has lost 25 percent or more of its initial tensile or compressive strength shall not be acceptable for transformer pad construction.

### 3.3 Impact Resistance Test

3.3.1 Transformer pads shall withstand transportation, handling, and installation without chipping, warping, or puncturing.

3.3.2 Transformer pads shall be able to withstand a right angle impact of 50 foot-pounds, using a weight having a C tup dimension per ASTM D2444. The pad shall be constructed to withstand an impact anywhere on the top or sides of the pad. Cracking or puncturing shall result in failure of the test. Denting or deformation at the point of impact shall not be considered as failure as long as moisture cannot penetrate into the pad. The test shall be run at  $0^{\circ}\text{C} \pm 2^{\circ}\text{C}$  and at  $40^{\circ}\text{C} \pm 2^{\circ}\text{C}$ .

### 3.4 Ultraviolet Testing

3.4.1 All exposed materials used to construct the pad shall be tested for ultraviolet exposure.

3.4.2 Samples of exposed material shall be tested per ASTM G-26-83, method A, apparatus type AH, with borosilicate glass fiber.

- a. Each sample piece of material is to be clean, dry, and free from covering before exposure.

- b. Each sample is to be exposed to 0.32 watts per square meter of ultraviolet light (340 nanometers wave length) for 2,000 continuous hours.
- c. Each sample is to be sprayed with room temperature de-ionized water for 18 continuous minutes every 2 hours of ultraviolet exposure.
- d. The black panel surface temperature in the sample chamber shall remain at 60 throughout the testing cycle.
- e. After 2,000 hours of exposure, the exposed sample surfaces are to be checked for surface chalking, discoloration, microscopic cracking. Any microscopic cracking is an indication of material degradation and results in rejection of the material.

### 3.5 Loading Test

3.5.1 Transformer pads must be able to pass the following static load test without signs of cracking, chipping, warping, or changes in shape. Depressions of up to ¼” caused by contact with gravel or depression of up to 1/16” caused by contact with the test frame are allowed, as long as they do not affect the pad structurally or do not allow the pad to absorb moisture.

- a. Transformer pads are to be supported by a bed of gravel. The gravel bed shall be at least 6” deep and composed of washed river gravel with rocks not smaller than ½” in diameter, or larger than 1” in diameter.
- b. Transformer pad 1, which is designed for only transformers 75 kVA and smaller, with BIL levels 125 kV or less, is to be loaded to 4,000 pounds. This pad is to be loaded using the test frame shown in Figure 3.5.A. The test frame shall be positioned and loaded as shown in Figure 3.5.B. The test load is to be maintained for 24 hours at –10°C or colder and for 24 hours at +45°C or warmer.
- c. Transformer pads 2 and 3, which are designed for transformer larger than 75 kVA or with BIL levels greater than 125 kV, shall be tested using the procedure outlined in Section 3.5.1.b. Following the test outlined in Section 3.5.1.b, the test is to be repeated, but a 6,000pound weight and the loading frame shown in Figure 3.5.C are to be used. For the second test, the test frame shall be positioned and loaded as shown in Figure 3.6.D.

### 3.6 Deflection and Security Test

3.6.1 Transformer pads must be able to pass the following deflection

test. The deflection test is designed to ensure that padmounted equipment that complies with Western Underground Committee Guide 2.13, "Security for Padmounted Equipment Enclosures", is not compromised by uneven pad setting.

- a. The test requires that two pieces of 2" wide channel iron be placed on a flat surface. The channel iron is to be separated by the full pad dimension "A" representing worst-case field conditions. (Refer to drawing 3.6.A)
- b. The pad being tested is to be placed on the two pieces of channel iron. The back of the pad is to be even with the back edge of one of the pieces of channel iron, and the front edge of the other channel iron. (Refer to drawing 3.6.A)
- c. For transformer pad 1, which is designed for transformers up to 75 kVA and BIL levels 125 kV or less, used the loading and deflection test frames shown in Figures 3.5.A and 3.6.C. The test frames are to be mounted and the loading frame loaded to 3,200 pounds per Figure 3.6.B, which represents maximum transformer weight times a safety factor of two.
- d. For transformer pads 2 and 3, which are designed for transformers larger than 75 kVA or for BIL levels greater than 125 kV, use the loading and deflection test frames shown in Figures 3.5.C and 3.6.C. The test frames are to be mounted and the loading frame loaded to 4,800 pounds per Figure 3.6.B, which represents maximum transformer weight times a safety factor of two.
- e. With the loading and deflection test frames positioned as required, if a No. 14 soft drawn copper wire can be passed between the pad and the deflection test frame or if a permanent crack develops, the pad is not acceptable.

### 3.7 Water Absorption Test

3.7.1 Samples of all finished material (plastic and non-plastic) used in pad construction that will be exposed to moisture shall be tested for water or moisture absorption. Sample shall be tested per ASTM D570-81. Material exceeding a water absorption rate of 0.60 percent by weight is not acceptable.

3.7.2 Water absorption test requirements can be waived if the manufacturer can show the following:

- a. Water absorption does not affect the strength of the material.
- b. Water absorption does not affect the weathering of the material or its ultraviolet resistivity.
- c. The material is unaffected by repeated freezing and thawing after absorbing moisture.

## **4.0 HARDWARE**

4.1 All exposed metallic surfaces including threaded inserts shall be either hot dipped galvanized or corrosion resistant stainless steel.

### 4.2 Threaded Inserts

4.2.1 Transformer pads shall contain two ½” 13 UNC threaded inserts to be used as transformer hold-downs. Threaded inserts for transformer hold-downs will be located as shown in Figure

4.2. These threaded inserts shall withstand a 500-pound straight pullout force and a 1,000-pound shear force at the pad surface. These loads include an engineering safety factor of two.

4.2.2 Transformer pads shall contain two ½” 13 UNC threaded inserts to be used for re-leveling the pad and transformer, should settling occur. Threaded inserts for re-leveling will be located as shown in Figure 4.2. Each of these threaded inserts shall withstand a straight pullout force equal to a safety factor of three times the pad’s maximum transformer weight; i.e., 4,800 pounds for pad 1 and 7,200 pounds for pads 2 and 3. Transformer pads weighing more than 100 pounds shall be tested to a total load of three times the sum of maximum pad plus maximum transformer weight.

4.2.3 Transformer pads weighing in excess of 40 pounds shall have a ½” 13 UNC threaded insert for lifting. The threaded insert shall be positioned over the center of gravity of the pad. The threaded insert shall have adequate strength for lifting and repositioning the pad; this shall be demonstrated by withstanding a test force of two times the maximum weight of the pad.

- 4.2.4 Treaded inserts shall withstand a 36 foot-pound torque.
- 4.2.5 All threaded inserts shall come with flush mounted plug, which is removable with pliers, screwdriver, or crescent wrench. The plug shall prevent dirt and water from building in the threaded insert.

## **5.0 DIMENSIONS**

5.1 Figure 5.1 gives dimensions for the three sizes of transformer pads.

5.2 Where transformer pads have a smooth bottom side, the manufacturer must provide a ¼” to ½” lip extending down around the edge of the pad or other means of preventing slippage. One means of preventing slippage would be adequate weight; e.g., a polymer concrete or an all-concrete pad weighing 40.0 pounds or more.

5.3 When transformer pads have a webbed bottom side, the manufacturer must provide a flat bearing surface at each corner. Pad 1 shall have a minimum of 64 square inches of surface at each corner. Pads 2 and 3 shall have a minimum of 100 square inches of surface at each corner. The bearing surface shall be located within ½” of the bottom edge of the pad.

## **6.0 MISCELLANEOUS**

6.1 Freezing – The pad shall be designed and constructed so that if it or any hardware used will trap or hold water, it will be able to withstand repeated freezing and thawing of the water.

6.2 Color – It is recommended that the utility using the pad accept black, green, or “natural concrete”.

6.3 Temperature Limits – The pad shall be capable of withstanding temperature variations of –40°C to +65°C while loaded, without cracking, splitting, or deforming.

6.4 Maximum Pad Weight – The maximum allowable pad weight is to be determined by the utility using the pad. Due to different requirements and different equipment for handling the pad, different utilities will have different maximum weight limits.

6.5 Identification – The transformer pad shall be permanently marked with the manufacturer’s name, catalog

number, and date of manufacture. This identification is to be located so as to be visible with a padmounted transformer installed.

6.6 Hold-Down Clips – When specified by the user, the manufacturer is to supply two hold-down clips and two bolts for each pad. The hold-down clips and bolts shall be designed to tie the transformer's front sill down to the hold-down threaded inserts mounted in the pad.





FIGURE 3.5.A  
TRANSFORMER LOADING TEST FRAME

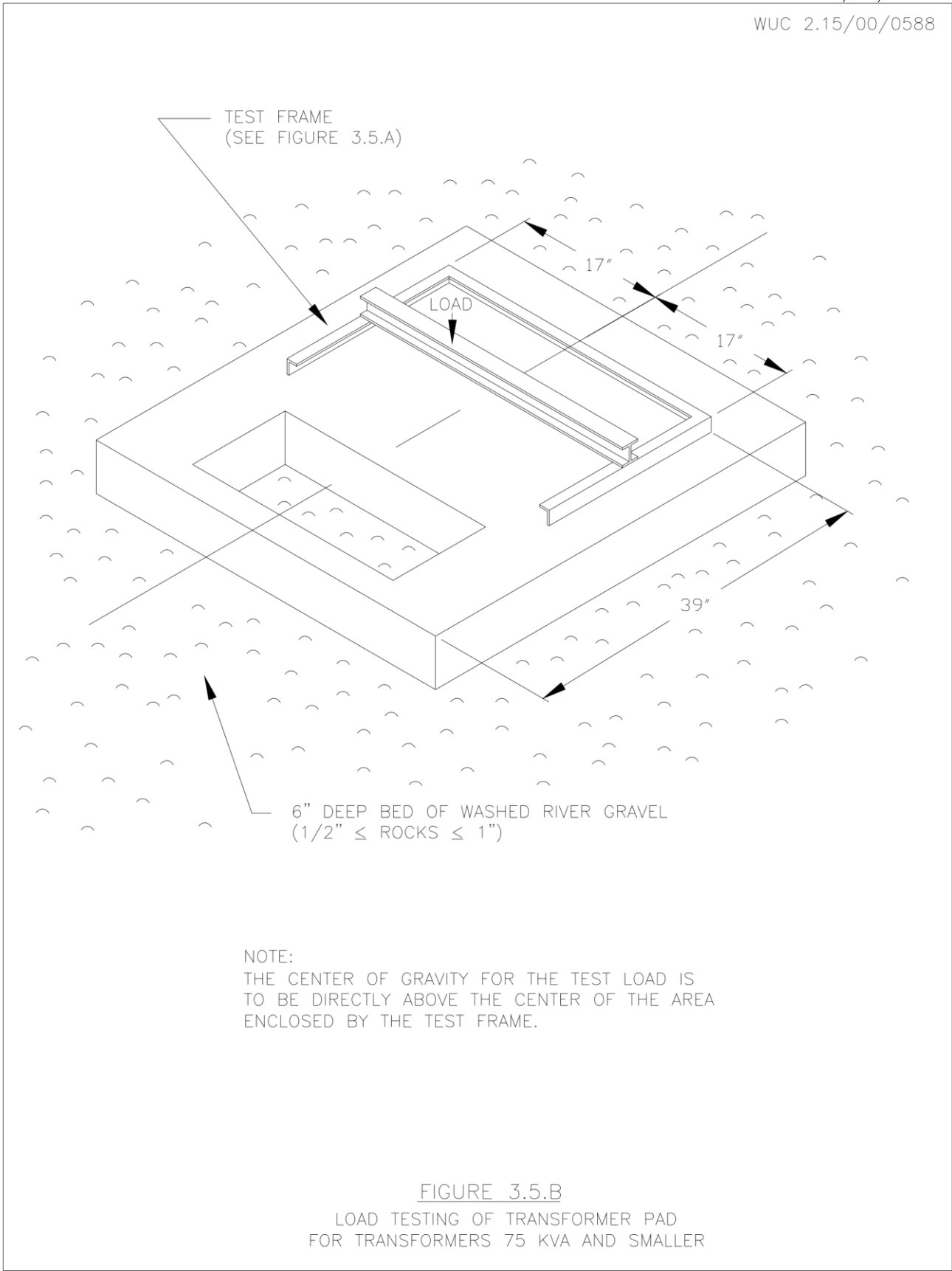
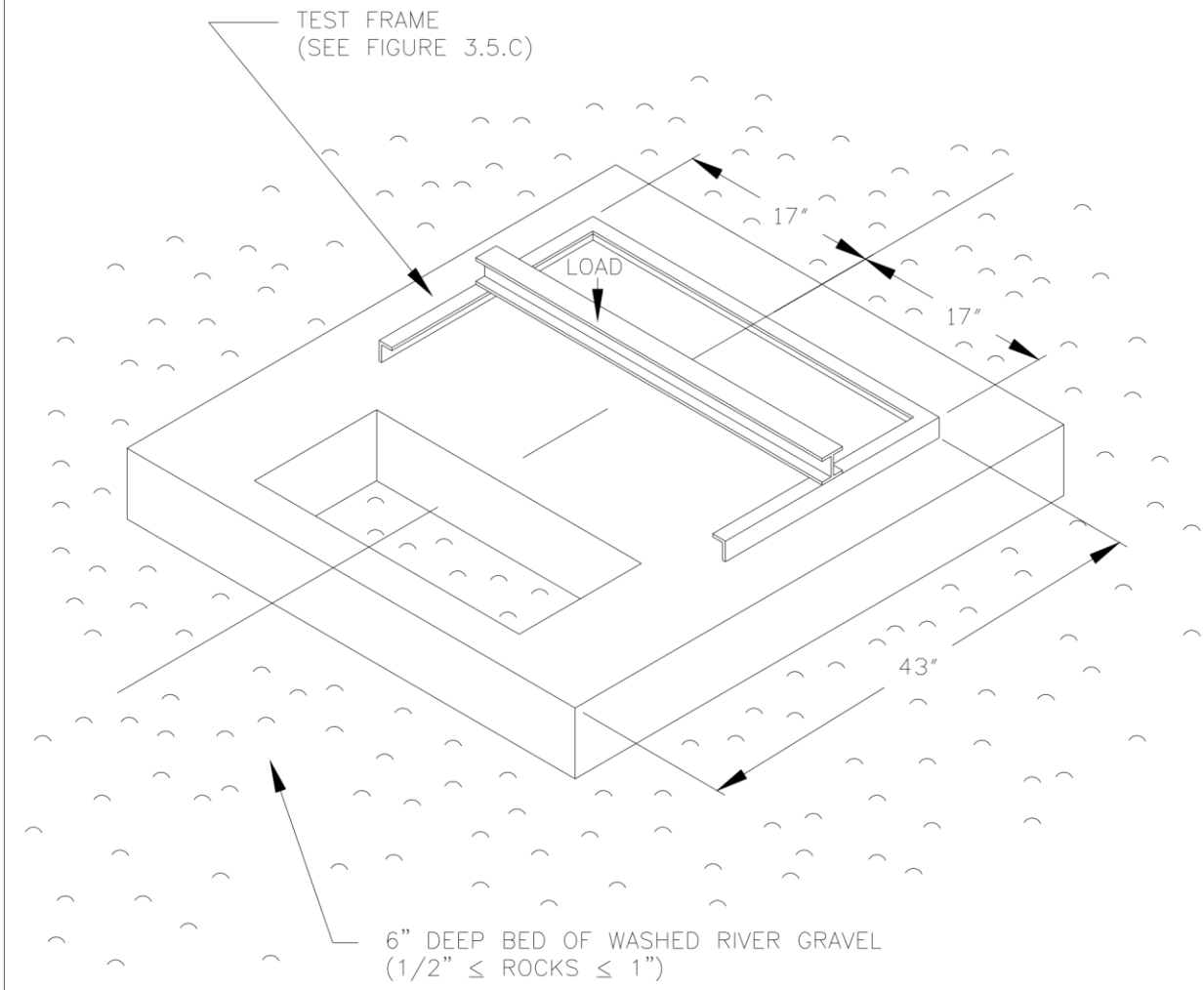

FIGURE 3.5.B  
LOAD TESTING OF TRANSFORMER PAD  
FOR TRANSFORMERS 75 KVA AND SMALLER



BOTTOM VIEW

FIGURE 3.5.C  
TRANSFORMER LOADING TEST FRAME



NOTE:  
THE CENTER OF GRAVITY FOR THE TEST LOAD IS  
TO BE DIRECTLY ABOVE THE CENTER OF THE AREA  
ENCLOSED BY THE TEST FRAME.

FIGURE 3.5.D  
LOAD TESTING OF TRANSFORMER PAD  
FOR TRANSFORMERS 75 KVA AND LARGER

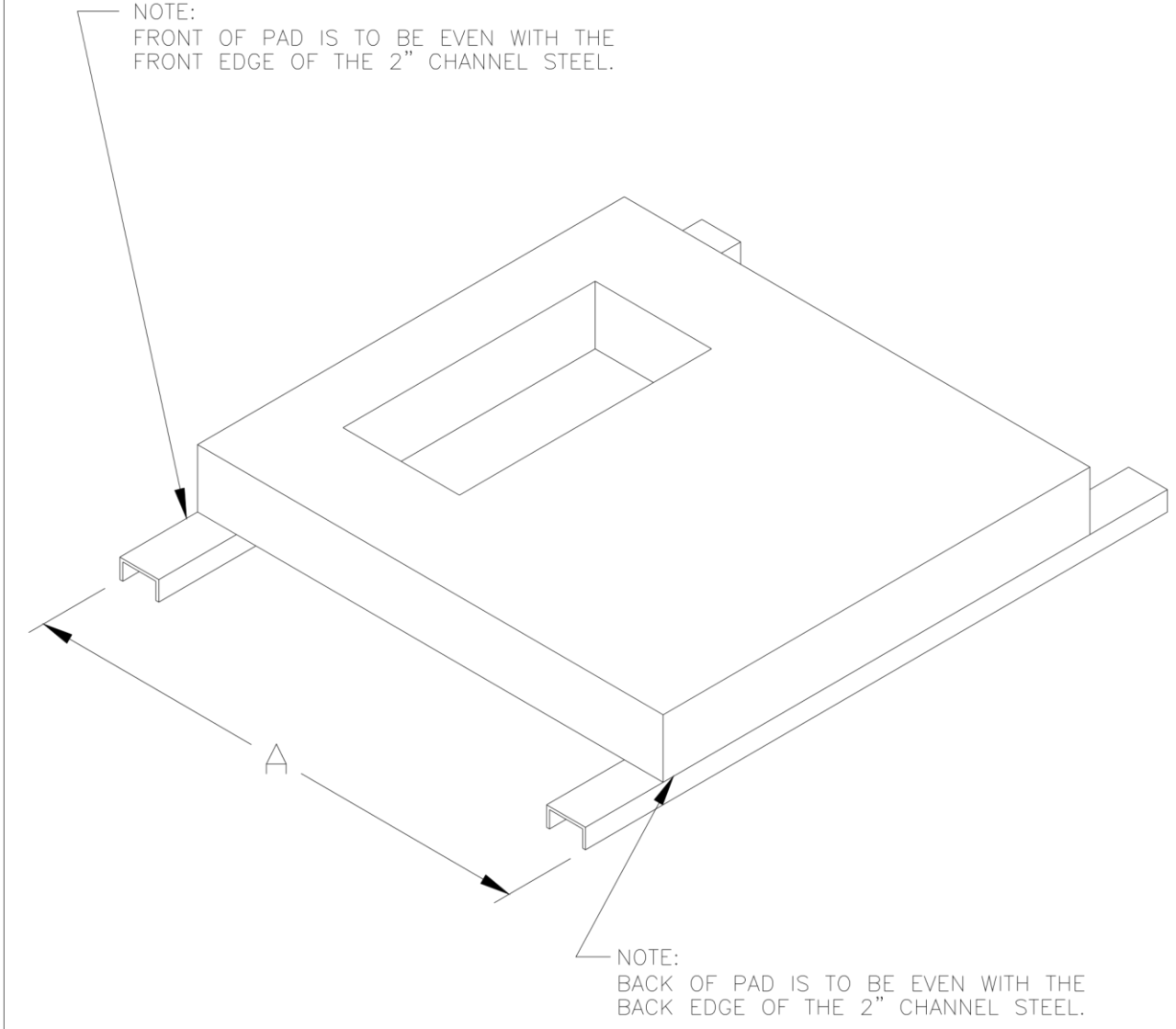
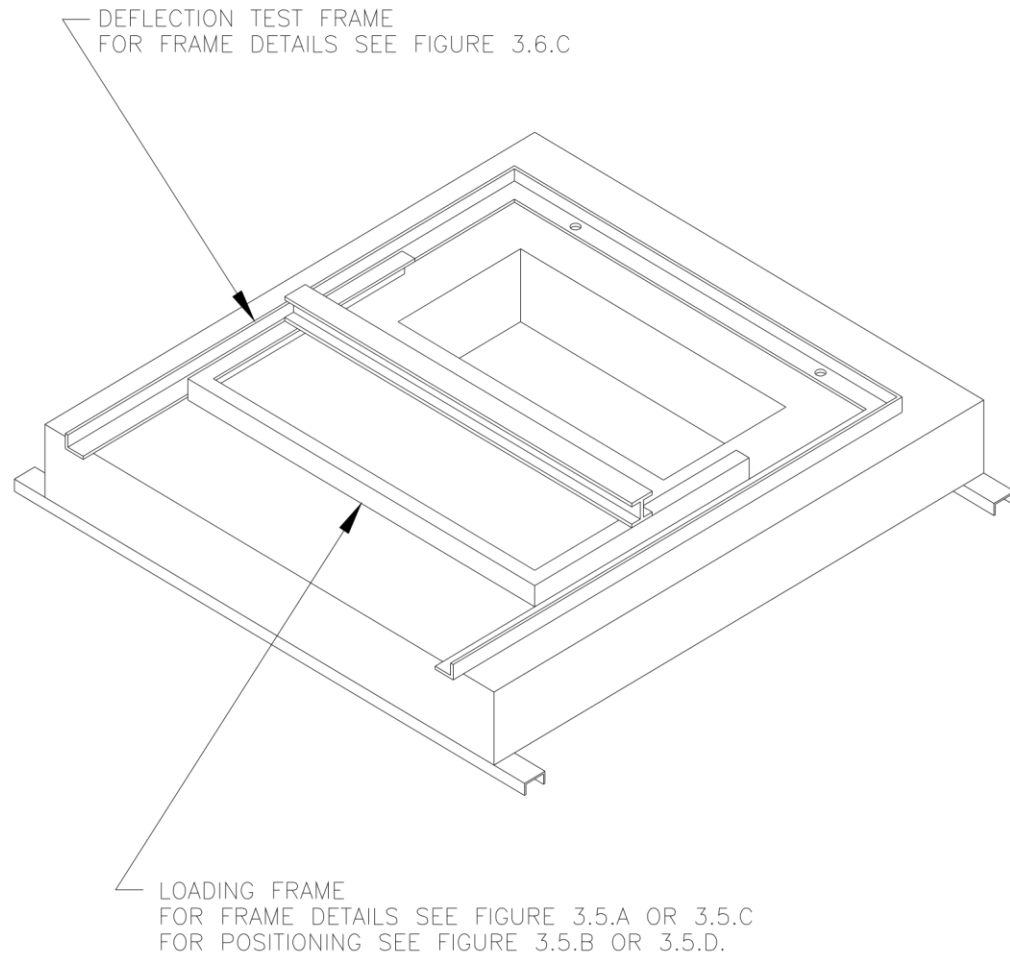

FIGURE 3.6.A  
DEFLECTION AND SECURITY TEST SUPPORT



NOTES:

1. DEFLECTION TEST FRAME SHALL BE BOLTED TO PAD.  
AN OPTIONAL "HOLD DOWN" LOAD OF 25 POUNDS MAY  
BE PLACED ON THE FRAME TO HOLD IT IN POSITION  
DURING THE TEST.
2. APPLY 3200 POUNDS OR 4800 POUNDS TO THE LOADING  
FRAME AS REQUIRED BY SECTION 3.6. THE CENTER OF  
GRAVITY FOR THE LOAD IS TO BE DIRECTLY ABOVE THE  
CENTER OF THE AREA ENCLOSED BY THE LOADING FRAME.

FIGURE 3.6.B  
DEFLECTION TEST

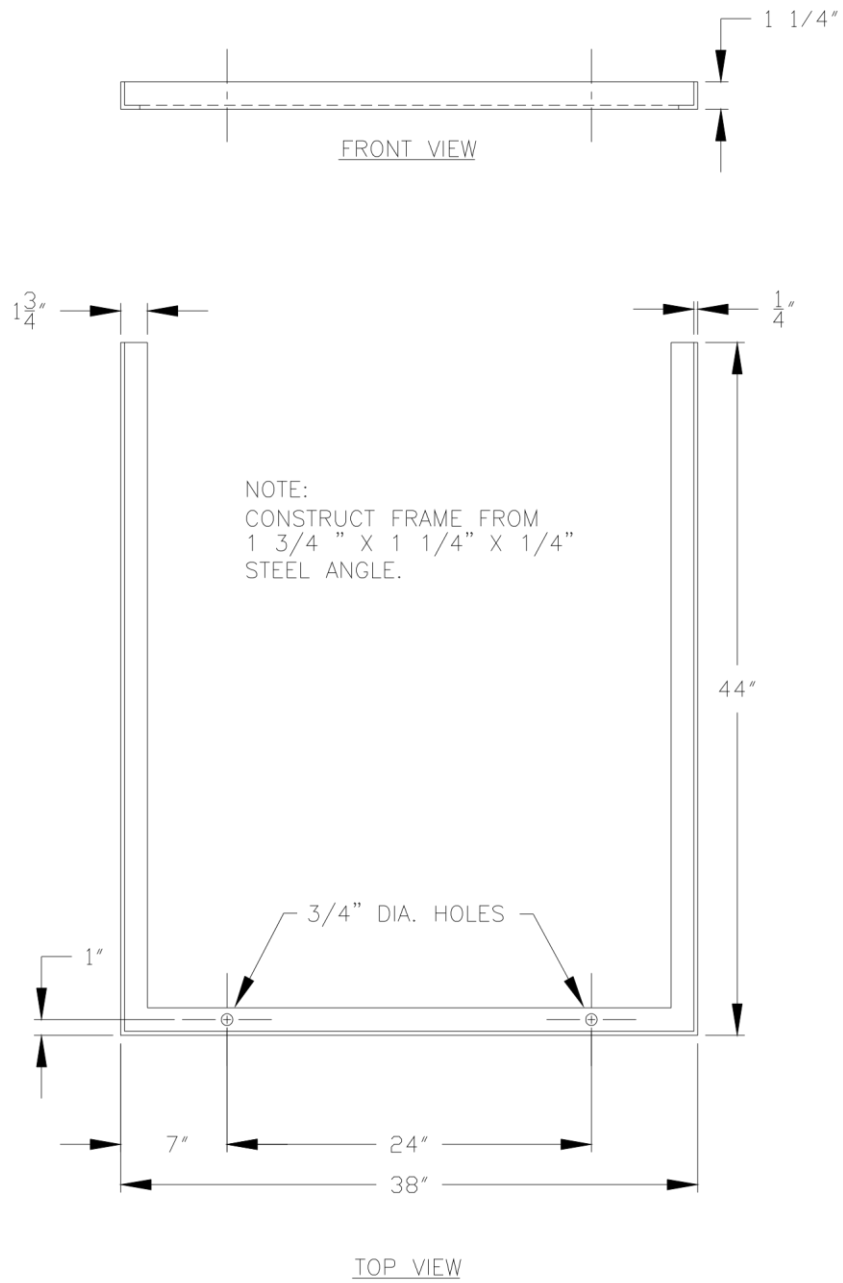
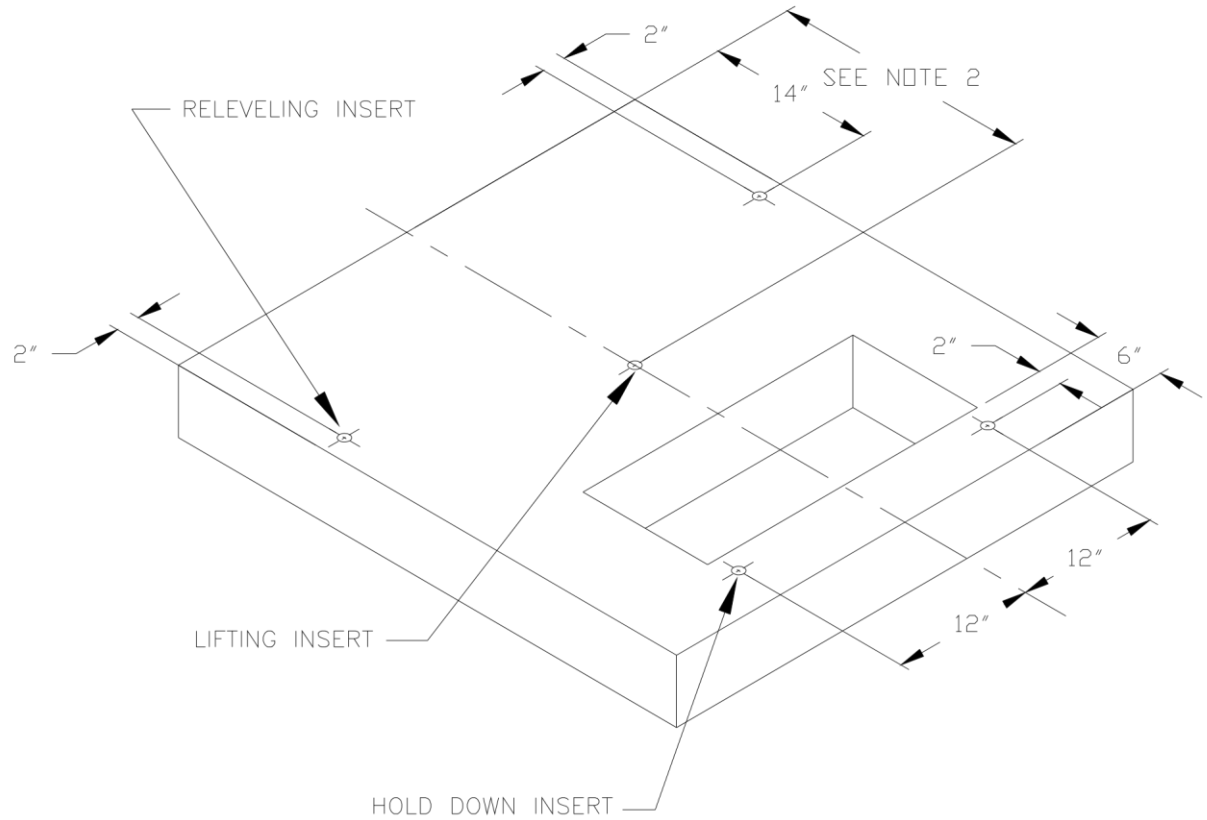

FIGURE 3.6.C  
DEFLECTION TEST FRAME



NOTES:

1. THREADED INSERTS ARE TO BE 1/2" 13 UNC AND ARE REQUIRED. (SEE SECTION 4.2 FOR DETAILS)
2. TRANSFORMER PADS WEIGHING IN EXCESS OF 40 POUNDS SHALL HAVE A THREADED INSERT FOR LIFTING. THIS INSERT IS TO BE POSITIONED OVER THE CENTER OF GRAVITY.

FIGURE 4.2  
LOCATION OF THREADED INSERTS



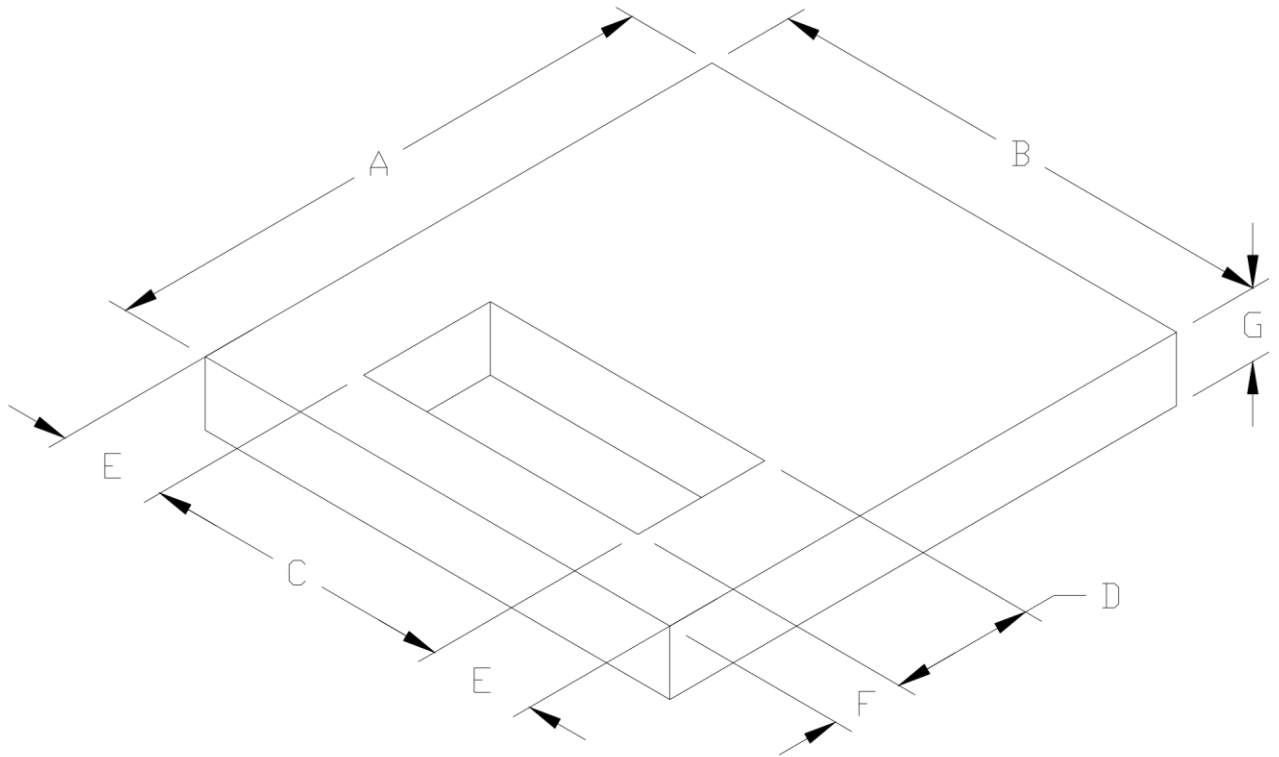

DIMENSIONS (INCHES)							
PAD #	A	B	C	D	E	F	G
PAD 1	42" MIN.	38" MIN.	20"-24"	10"-12"	9" MIN.	6" MIN.	3 1/4" MIN.
PAD 2	48" MIN.	44" MIN.	20"-24"	12"-15"	12" MIN.	6" MIN.	4" MIN.
PAD 3	54" MIN.	48" MIN.	24"-26"	12"-15"	12" MIN.	6" MIN.	4" MIN.

PAD 1 IS FOR TRANSFORMERS 75KVA AND SMALLER WITH BIL'S 125 KV OR LESS, AND WEIGHING A MAXIMUM OF 1600 POUNDS.

PAD 2 IS FOR TRANSFORMERS LARGER THAN 75KVA OR WITH BIL'S GREATER THAN 125 KV, AND WEIGHING A MAXIMUM OF 2400 POUNDS.

PAD3 IS FOR ALL KVA SIZES OF TRANSFORMERS WEIGHING A MAXIMUM OF 2400 POUNDS, WHERE A LARGER PAD IS REQUIRED DUE TO OPERATING PRACTICES AND OTHER REQUIREMENTS.

FIGURE 5.1  
SINGLE PHASE  
TRANSFORMER PAD DIMENSIONS