

# **WESTERN UNDERGROUND COMMITTEE**

## **GUIDE 2.14 (2.14/01/0990)**

### **ABRASION RESISTANT 600V CABLE**

NOTE: This "Guide" summarizes the opinions, recommendations, and practices of the Western Underground Committee members and is issued only to assist these members in preparing their own specifications, or in making recommendations to specification agencies. Thus, this "Guide" may not reflect the complete requirements of each individual utility and is not binding upon them.

#### **1.0 SCOPE**

1.1 This guide covers 600 volt rated, polyethylene (PE) or cross-linked polyethylene (XLP) insulated single conductor, duplex, and multiconductor cables.

1.2 This cable shall be suitable for operation on electric distribution systems:

1.2.1 In direct sunlight, in conduits or ducts either above or below ground, and directly buried in the earth.

1.2.2 At either 75°C (PE) or 90°C (XLP) conductor temperature under normal operating conditions.

1.2.3 At either 90°C (PE) or 130°C (XLP) conductor temperature under emergency conditions not exceeding either 100 hours per year or 500 hours total.

#### **2.0 GENERAL**

2.1 All cable shall comply with applicable requirements of ICEA Publication S-61-402 or S-66-524, current edition with additions, options, and exceptions, and exceptions as detailed in this guide.

2.2 The manufacturer shall be responsible for ensuring the compatibility among all components of the cable.

2.3 All phases of cable manufacturing and testing shall be accomplished with care and good workmanship.

#### **3.0 MATERIAL OR DESIGN CHANGES**

Approval as a supplier of cable covered by this guide includes approval of the specific design and materials last submitted for approval. Thereafter, supplier shall not make significant changes in the design or materials of approved cable without prior approval. Failure to comply with this requirement may result in withdrawal of approval.

#### **4.0 CONDUCTORS**

4.1 When aluminum is required, the metal shall be either hard drawn conforming to ASTM B230 or three quarters hard drawn conforming to ASTM B609 with class B stranding per ASTM B231.

4.2 When copper is required, the metal shall be 100% IACS coated or uncoated copper conforming to ASTM B3 with class B stranding per ASTM B8.

#### **5.0 INSULATION**

5.1 The insulation shall be black thermoplastic or thermosetting polyethylene conforming to ICEA S-61-402 or S-66-524, with the following additions for thermoplastic material.

5.1.1 Two-layer construction:

5.1.1.1 Inner layer – The insulation shall be Type I, Class C, category 4 or 5, Grade E5 polyethylene per ASTM D1248-78.

5.1.1.2 Outer layer – The insulation shall be Type III, Class C, category 5, Grade E11 polyethylene per ASTM D1248-78.

5.1.2 Single layer construction:

The insulation shall be Type II or III, Class C, category 4 or 5, Grade E11 per ASTM D1248-78.

5.2 The insulation shall be free stripping from the conductor.

5.3 A polyester film or similar thin separator may be used between the conductor and insulation. It shall be colored and clearly recognizable.

5.4 The minimum insulation thickness at any point for the total (inner layer and outer layer) shall not be less than 90 percent of the specified minimum average “MIL” thickness.

5.4.1 If requested by the purchaser, the manufacturer may furnish inner and outer insulating layers, which are different than shown in Table I.

5.5 The cable shall be tested at the voltages shown in Table I.

5.6 Single conductor cables shall be immersed in water for at least six hours and multiple conductor cables at least one-hour prior to insulation resistance testing. Cables shall be tested in accordance with paragraph 6.14.2 and 6.15.3 of ICEA S-66-524.

TABLE I

Conductor Size <u>AWG or Kcmil</u>	<u>Insulation Thickness</u> “mils”			AC Test		DC Test			
	<u>Inner</u>	<u>Outer</u>	<u>Total</u>	<u>Voltage kV</u>		<u>Voltage kV</u>			
1-4/0 1,000	30 45	50 65	80 110	7.0 10.0	21.0 30.0	250-500	45 50 95	8.0 24.0	501-

**6.0 MULTIPLE CONDUCTOR CONSTRUCTION**

6.1 Triplexed Cable: Triplexed cable assemblies shall conform to the requirements of the specifying utility.

6.2 The shipping length of multiple conductor cables shall be the measured length of the completed cable assembly.

**7.0 MARKING**

7.1 Each cable shall be legibly and permanently marked, at intervals of approximately one foot, showing: Supplier’s identification, rated voltage (600 volts), size and type of conductor, year of manufacture, and type of insulation.

7.1.1 Supplier’s trade name alone is not sufficient identification of type of insulation.

7.2 Single conductor insulation shall, in addition to 7.1, be marked with durable sequential footage marking at least every two feet along the cable length.

7.3 Multiple conductor cables shall, in addition to 7.1, have sequential footage markings consisting of yellow printing along the neutral conductor. If the neutral insulation is all yellow, the printing shall be of contrasting color.

7.3.1 The neutral conductor shall be identified in accordance with the requirements of the specifying utility.

## **8.0 SEALS**

The conductor shall be dry when shipped, and cable ends shall be effectively sealed to prevent entrance of moisture during transit or storage.

## **9.0 TESTS**

9.1 Upon request, suppliers shall furnish to the utility two copies of certified test reports of all tests, including tests in 9.2. Copies of tests requiring less than one week to complete shall be sent on or before the day the cable is shipped, and copies of all tests requiring one week or longer to complete shall be sent as soon as possible.

9.2 In addition to the tests specified in ICEA S-61-402 and S-66-524, the cables shall be tested for the following: (These are qualification tests to be performed originally or upon design changes.) Test sample shall be 1/0 aluminum conductor with 80 mils total insulation thickness. Dimensions of insulation layers shall be reported along with test results. These tests are for engineering information only.

9.2.1 Unless otherwise shown in Figures 1-3, the maximum radius (due to wear) for any contacting test point shall be 23 mils.

9.2.2 Abrasion – This test shall be done by a weighted (25 lbs.) scalloped foot resting on the cable sample. The sample is attached to a reciprocating table and moving at a speed of 30 cycles per minute until the insulation is scraped through. Failure is indicated by electrical contact between the foot and the conductor. This apparatus is similar to that specified in UL44, section 83. (See Figure 1, Detail A, page 8).

9.2.3 Scoring – This test method is the same as described in 9.2.2 except light weighted (4.4 lbs.) spike is used instead of a scalloped foot. (See Figure 1, Detail B, page 8).

9.2.4 Crush – For the crush test, a ¼” diameter rod at 90° to the cable sample, is pressed into the sample at a speed of one half inch per minute. Failure is indicated by electrical contact between the rod and conductor. The UL44, Section 81, crush test equipment can be used. (See Figure 2, Detail A, page 9).

9.2.5 Puncture – The test method is the same as described in 9.2.4 except a 1/3” spike with a 60° conical tip is pressed into the cable sample at a speed of one half inch per minute. (See Figure 2, Detail B, page 9).

9.2.6 Nicking – A 50 inch long swing arm with a slightly sharp head and a total weight of 17.8 lbs. is released from increasing heights until failure occurs. Failure is indicated by electrical contact between the head and conductor. (See Figure 3, Detail A, page 10).

9.2.7 Blunt Impact – The test method is the same as described in 9.2.6 except a blunt blade is used. (See Figure 3, Detail B).

9.2.8 Sharp Impact – The test method is the same as described in 9.2.6 except a sharp blade is used. (See Figure 3, Detail C).

9.2.9 Long-Term Power Factor Test. EM-60 of ICEA S-66-524 is to be used for the power test with the following exceptions:

9.2.9.1 Immersed in 75° C water for thermoplastic and 90° C water for thermosetting insulations.

9.2.9.2 Energized continuously at 600 volts AC (except during Power Factor measurements).

9.2.9.3 Testing to be conducted weekly for a period of (at least) six months.

9.2.10 Long Term Insulation Resistance Test.

9.2.10.1 Cable shall be immersed in 75°C water for

thermoplastic and 90° C water for thermosetting insulations.

9.2.10.2 Testing to be conducted weekly for a period of (at least six months. (Test shall show stability at the end of six months.)

9.2.10.3 Testing to be performed weekly using standard equipment and procedures with the results reported in Megohms – 1000 feet at 500 volts DC minimum.

9.2.10.4 Energized continuously at 600 volts AC.

## **10.0 REEL**

Reel size requirements and standard shipping lengths shall conform to those shown in WUC Guide 1.4.

## **11.0 INFORMATION TO BE SUPPLIED BY PURCHASER**

11.1 Purchaser will supply the following information:

11.1.1 Cable Data:

11.1.1.1 Material code number

11.1.1.2 Quantity required, in feet

11.1.1.3 Size, AWG or kcmil, copper or aluminum

11.1.2 Shipping destination

11.1.3 Special reel size, if required.

4.4 LBS. - SCORING TEST  
25 LBS. - ABRASION TEST

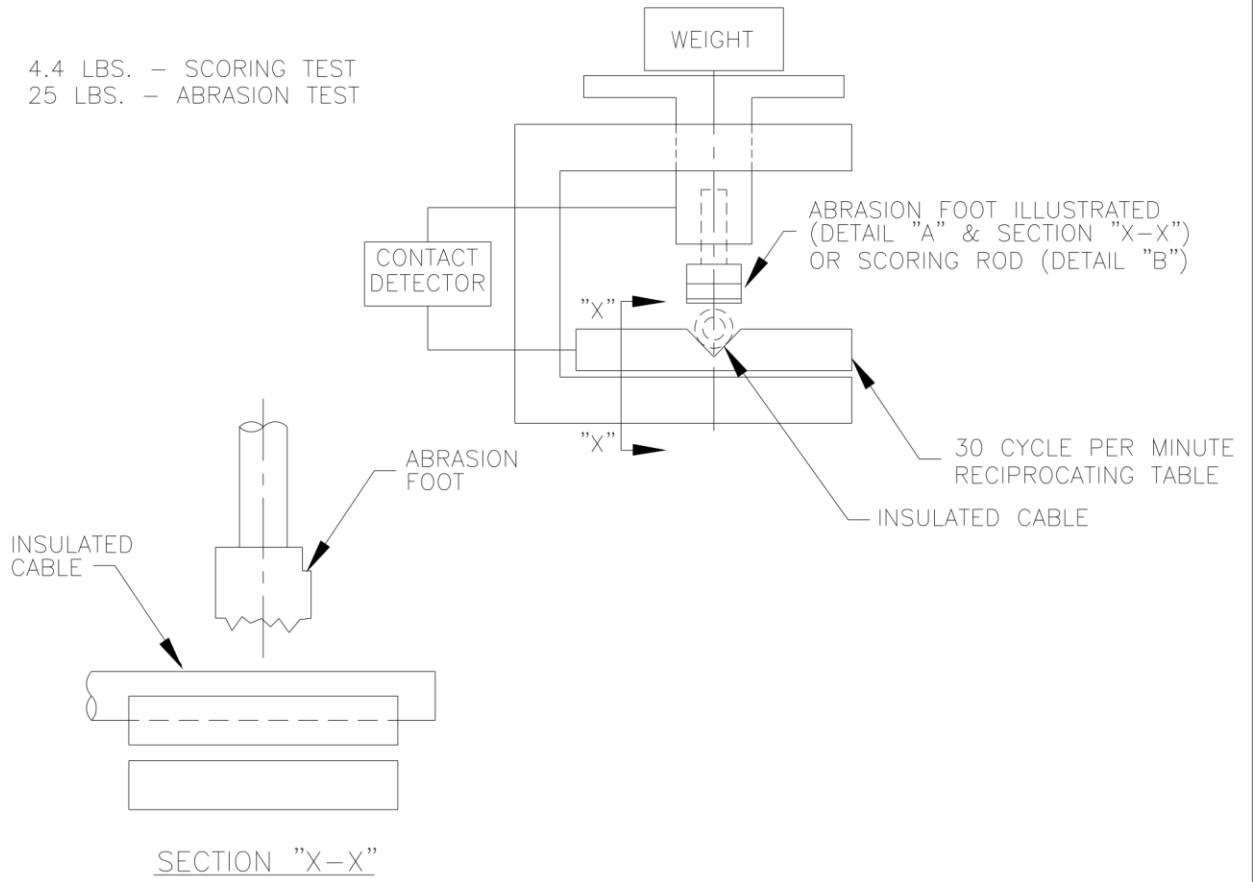

SECTION "X-X"

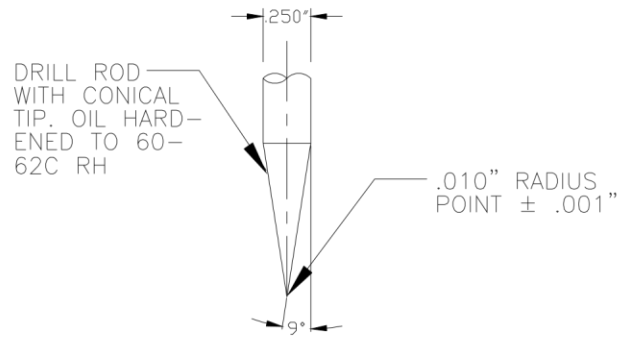
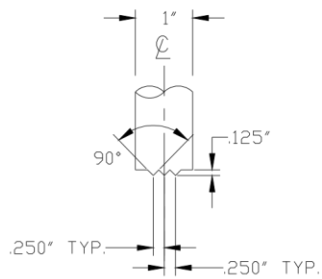

MODIFIED UL 44 SCORING APPARATUS

FIGURE 1  
SCORING AND ABRASION TEST DEVICE

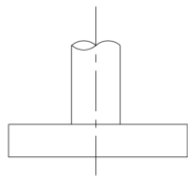
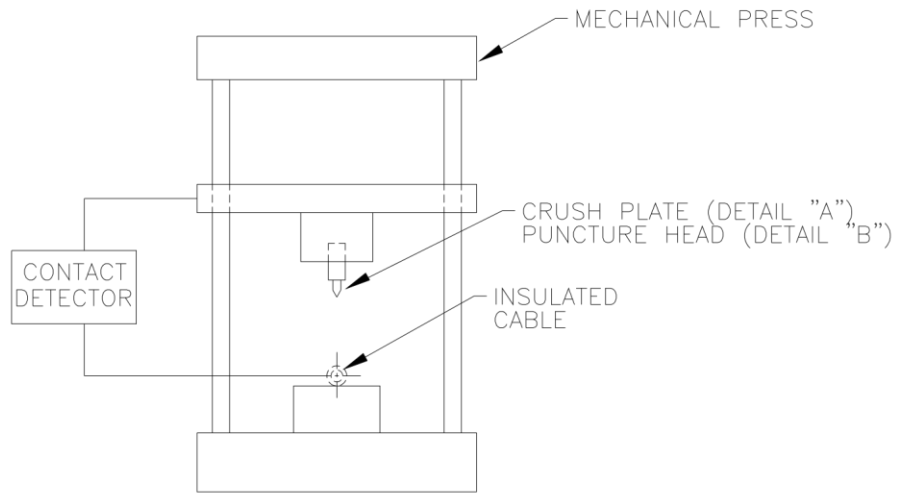

DETAIL "A"

CRUSH PLATE  
SPEED: 1/2" PER MIN.  
1/4" ROD AT 90° ANGLE  
TO SAMPLE.

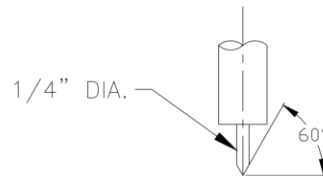

DETAIL "B"

PUNCTURE HEAD  
SPEED: 1/2" PER MIN.

MODIFIED UL 44 CRUSH TEST DEVICE SECTION 81

FIGURE 2  
PUNCTURE AND CRUSH TEST



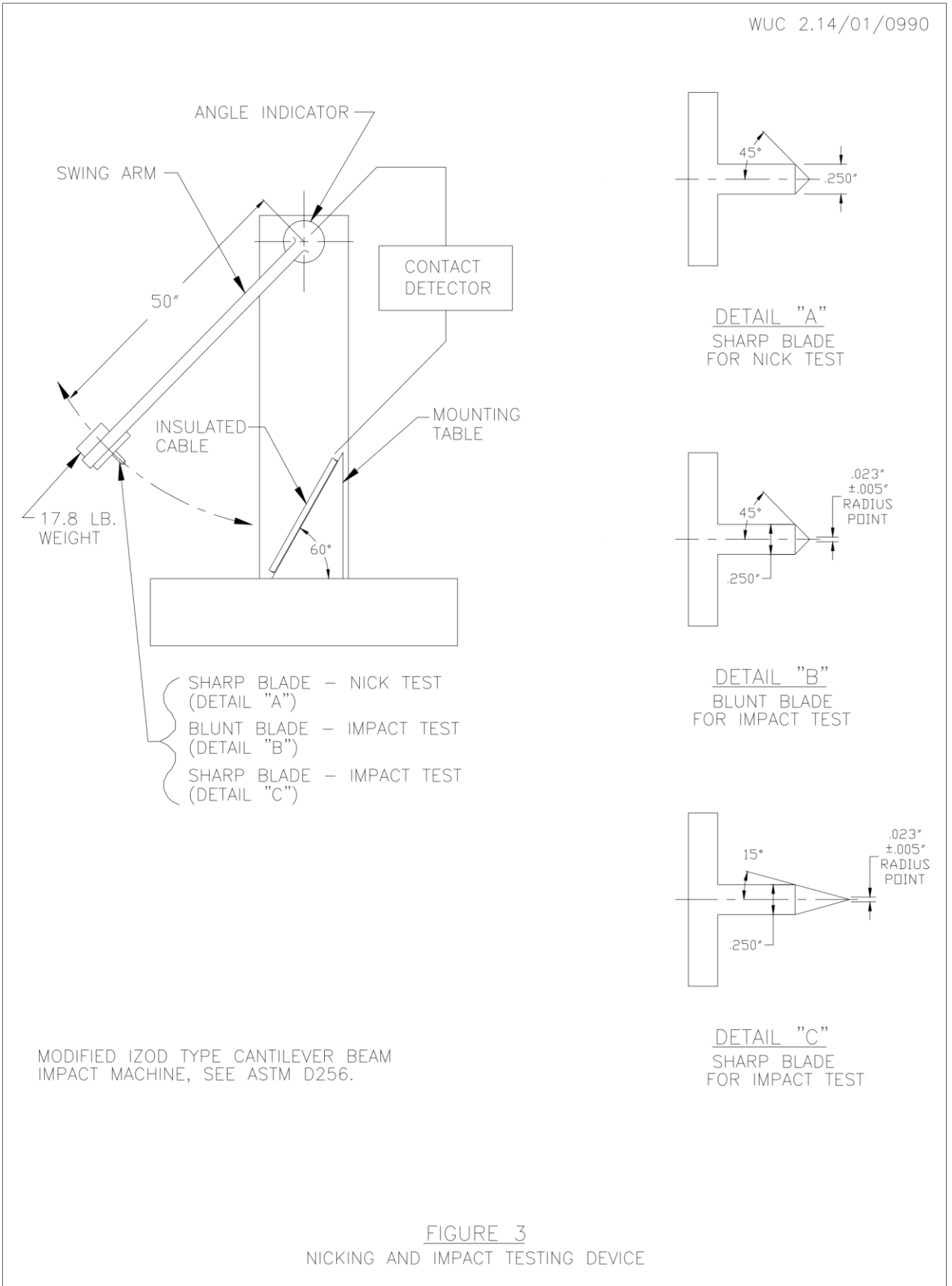

FIGURE 3  
NICKING AND IMPACT TESTING DEVICE