

WESTERN UNDERGROUND COMMITTEE

GUIDE 3.5 (3.5/00/0270)

SUBSURFACE TRANSFORMER ENCLOSURES

NOTE: This "Guide" summarizes the opinions, recommendations, and practices of the Western Underground Committee members and is issued only to assist these members in preparing their own specifications, or in making recommendations to specification agencies. Thus, this "Guide" may not reflect the complete requirements of each individual utility and is not binding upon them.

1.0 SCOPE AND CLASSIFICATION

- 1.1 This specification covers the subsurface transformer enclosure for installation in underground construction for residential distribution systems.
- 1.2 Classification – The enclosure is for use by electrical utilities.

2.0 GENERAL DESIGN CHARACTERISTICS

The attached drawings, (figure1, page 3) in its latest issue, is a part of this specification.

3.0 SIZES AND FITTINGS

- 3.1 Sizes are as specified in figure 1.
- 3.2 Fittings are as specified in figure 1.

4.0 MATERIALS

Material for construction of the enclosure is as specified.

5.0 PUBLICATIONS

None

6.0 REQUIREMENTS

Requirements are as specified.

7.0 INSPECTIONS

The manufacturer will certify that the enclosure on each lot or shipment or as required by the purchaser meets this specification.

8.0 NOTES

- 8.1 Ordering Data – Purchaser should specify the sizes or other requirements or options needed.
- 8.2 It is believed this recommendation standard adequately describes the characteristics necessary to secure the desired items and that normally no samples will be necessary prior to award to determine compliance with this recommended standard. If, for any particular purpose, samples with bids are necessary, they should be specifically asked for in the invitation for bids; and the particular purpose to be served by the bid sample should be definitely stated. This recommendation standard is to apply in all other respects.
- 8.3 Marking, Identification and Inspection – No order of marking is specified. Any additional information deemed necessary by the purchaser is permitted.
- 8.4 Suggestions for revision and correspondence concerning this specification should be addressed to the:
Chairman,
Western Underground Committee.
(For address, see any member of the committee)
- 8.5 This specification may be reproduced in whole provided proper credit is given the Western Underground Committee.

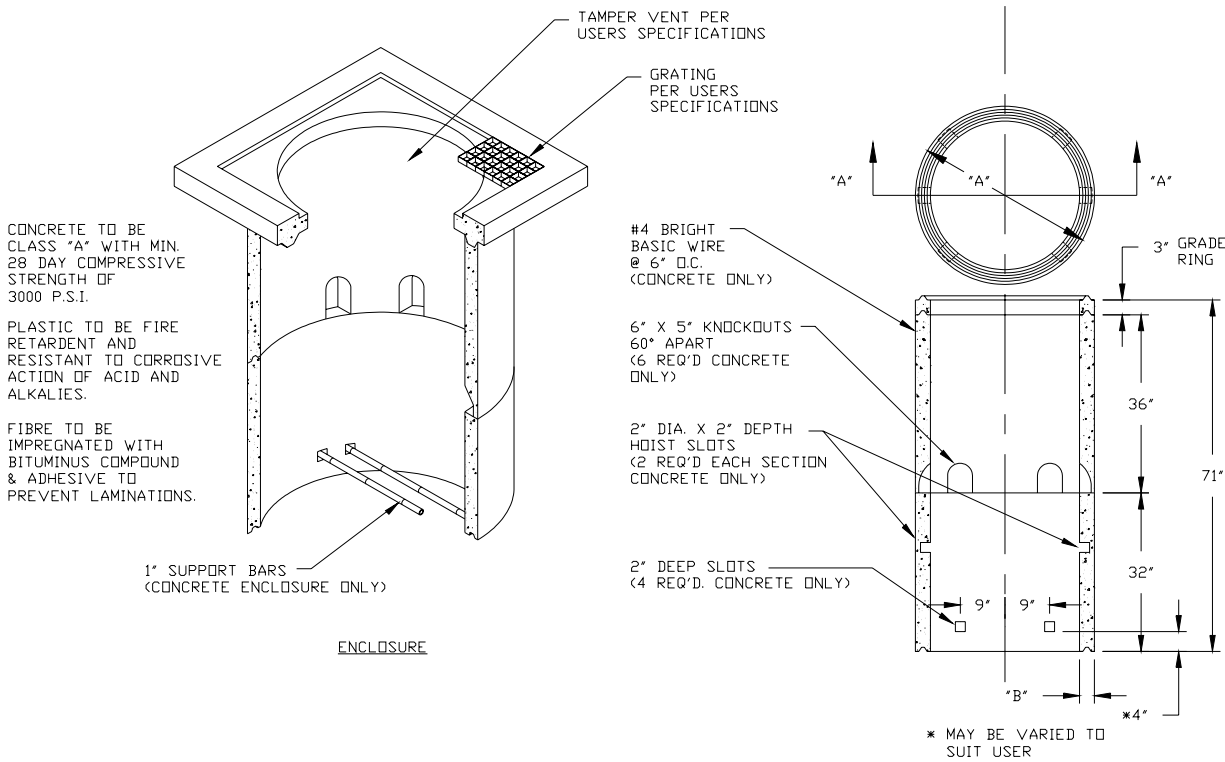

TYPE NO.	CONCRETE		PLASTIC		FIBRE	
	A	B	A	B	A	B
E1	36"	3"	36"	.36"	36"	.50"
E2	42"	3"	42"	.42"	42"	.53"

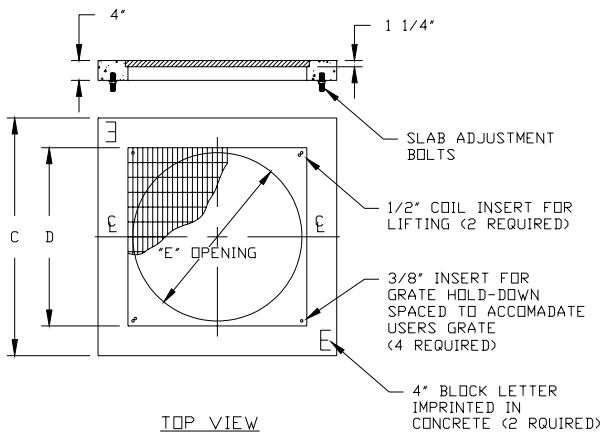

TOP DIMENSIONS			
TYPE NO.	C	D	E
T1	44"	32 1/4"	30"
T2	48"	36 1/2"	34"

- GENERAL NOTES:
1. THIS DRAWING SHOWS ENCLOSURES TO BE USED IN NON-TRAFFIC AREAS.
 2. PASTIC AND FIBRE ENCLOSURES MAY BE ONE PIECE CONSTRUCTION IF PROVISIONS HAVE BEEN MADE FOR GRADE ADJUSTMENT.
 3. GRATE AND TAMPER VENT DESIGN TO VARY TO MEET THE REQUIREMENTS OF THE PURCHASING UTILITY.
 4. FORMS USED IN THE MANUFACTURE OF THESE ENCLOSURES SHALL BE OF SUFFICIENT STRENGTH TO MAINTAIN A TOLERANCE OF +1/4", -0".
 5. DEFLECTION OF PLASTIC AND FIBRE ENCLOSURES TO BE 1.75" MAXIMUM WITH SIDE-SOIL COMPACTION OF 85%.

FIGURE 1
SUBSURFACE TRANSFORMER ENCLOSURE